

Outline

The MW3827 is a combined relative humidity and temperature sensor module. The dual sensor is also combined with our custom analog front end to provide a fully calibrated and temperature compensated digitized I2C output. The MW3827 proprietary polymer and parallel plate capacitive structure provides excellent

robustness and reliability. No complicated sensor drive or control circuit is required, and high performance sensing is achievable only with the MW3827 and an external microcontroller which works as a host.

Features

(Unless otherwise specified, T_{opr}=+25°C)

- ① Small package: 2.0(W) × 2.0(D) × 0.8(H)mm
- ② Current consumption 8.97μA Typ. (@1sample/sec.) Current consumption at sleep 0.85μA Typ.
- ③ Output corrected humidity value with repeatability of 0.015%RH.
- ④ Equipped with a heater for checking operation
- ⑤ 8-bit I2C address 50h(Write), 51h(Read)
- ⑥ Specifications

● Sensing principle	Capacitive
● Supply voltage	2.2~5.5V
● Operation temperature	-40~105°C
● Humidity range	0~100%RH.
● Humidity accuracy @25°C 50%RH.	±2%RH.
● Humidity hysteresis	±1%RH.
● Response time	6sec
● Temperature accuracy @25°C	±0.5°C
● Interface	I2C
● Size	2.0(W) × 2.0(D) × 0.8(H)mm

Applications

Air conductor, refrigerator, dehumidification fan, heat exchanger, environmental monitoring, medical

Block diagram

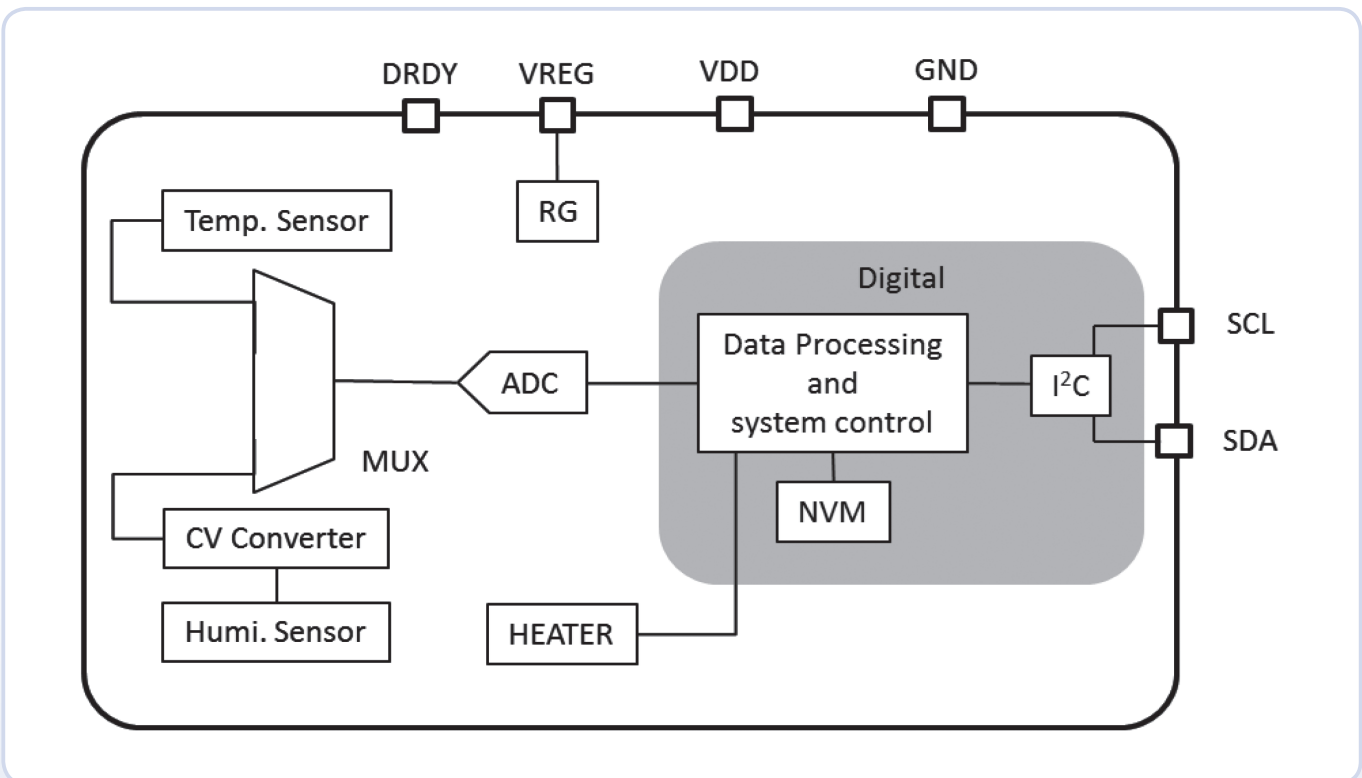

Dimensions

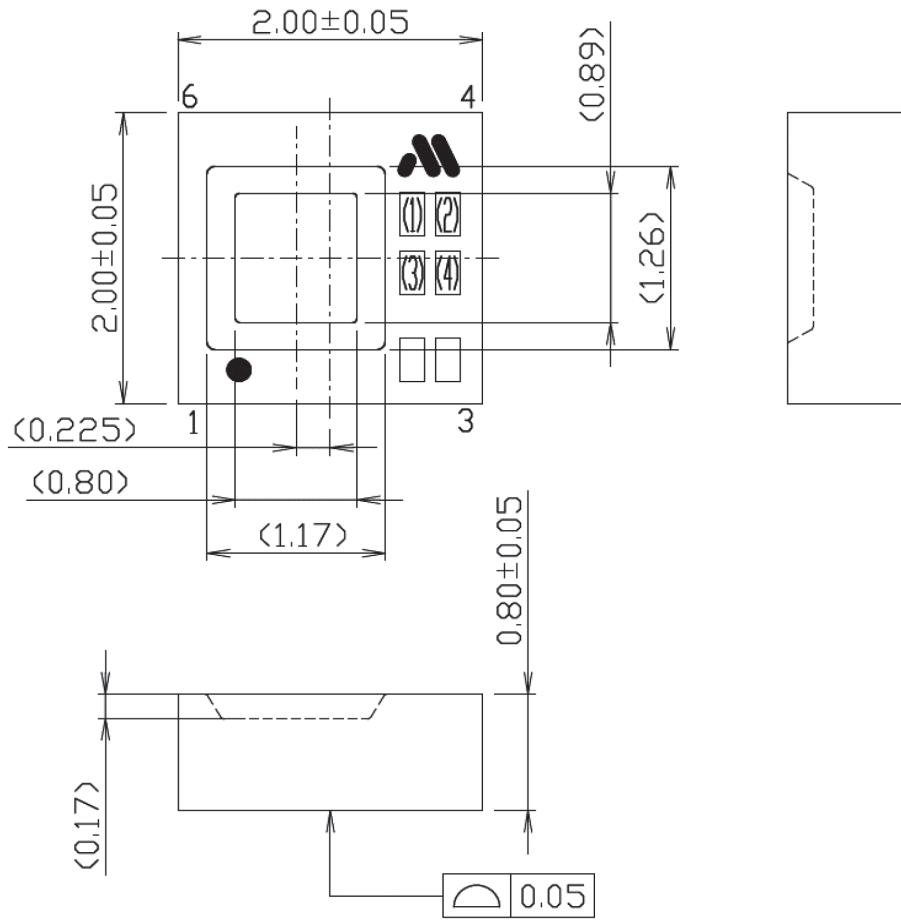

裏面 (Bottom View)

