

Temperature Sensor for I²C BUS

Monolithic IC MM3286 Series

Outline

This IC is used as a digital temperature sensor that supports I²C BUS and has the built-in temperature sensor and Δ - Σ type A/D converter. This IC is always accessible for acquiring the temperature data, and it can detect abnormal temperature because it has a separate open drain output terminal that can operate as thermostat.

This IC features low consumption current and has the interface that supports I²C BUS, and thus it is suitable for a variety of applications.

Features

1. Low consumption current (75 μ A typ.)
2. Shutdown mode to minimize consumption current
3. Interface supporting I²C BUS
4. Capable of carrying up to 8 ICs in the bus.
5. Thermostat function (The number of detections is programmable up to 6 times.)
6. Temperature data has 9-bit resolution in which 1 LSB is 0.5°C.

Package

SOP-8D

Applications

1. LCD TV
2. PC
3. PC server/Network server
4. System temperature monitoring
5. Equipment OA

Block Diagram

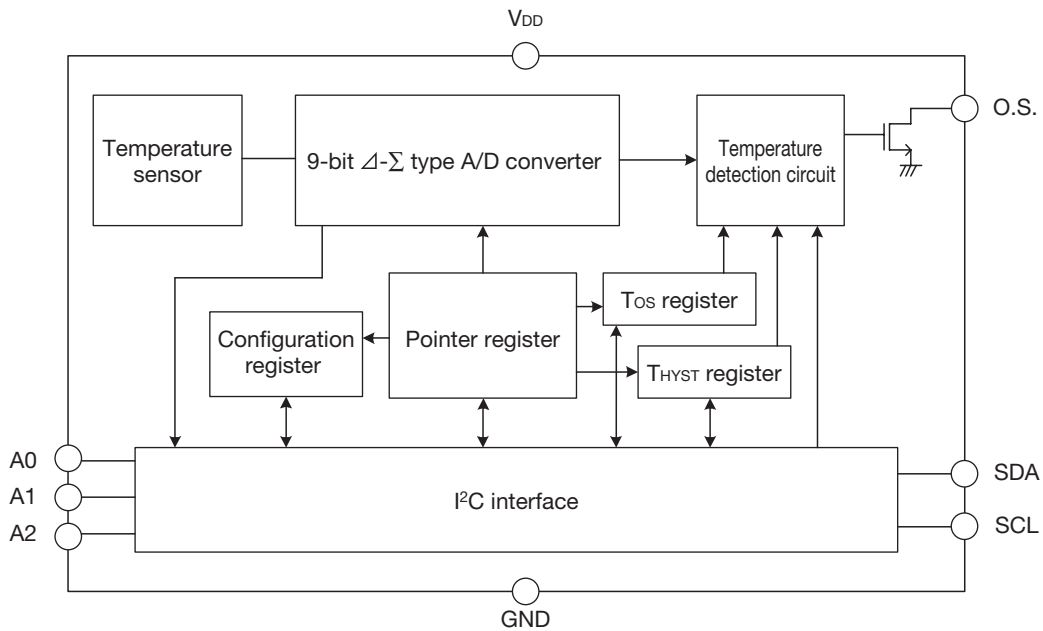

Pin Assignment

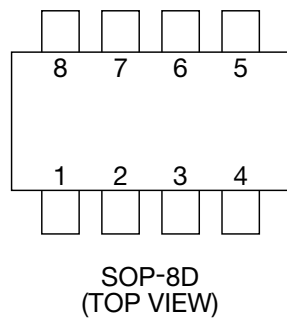

1	SDA
2	SCL
3	O.S.
4	GND
5	A ₂
6	A ₁
7	A ₀
8	V _{DD}

Pin Description

Pin No.	Pin name	Functions	Internal equivalent circuit diagram
1	SDA	I ² C BUS data I/O	
2	SCL	I ² C BUS clock input	
3	O.S.	Temperature detection output	
4	GND	GND	
5	A ₂	Slave address setup	
6	A ₁		
8	A ₀		
8	V _{DD}	Power supply	

Absolute Maximum Ratings (Ta=25°C)

Item	Symbol	Ratings	Units
Maximum supply voltage	V _{DD max.}	-0.3~+6.0	V
Maximum output voltage	V _{OUT}	-0.3~(V _{DD} +0.3)	V
Allowable loss	P _d	300	mW
Storage temperature	T _{STG}	-65~+150	°C

• Any products mentioned in this catalog are subject to any modification in their appearance and others for improvements without prior notification.
 • The details listed here are not a guarantee of the individual products at the time of ordering. When using the products, you will be asked to check their specifications.

Recommended Operating Conditions

Item	Symbol	Ratings	Units
Operating supply voltage	V _{DD OPR}	+3.0~+5.5	V
Operating temperature	T _{OPR}	-40~+125	°C

Electrical Characteristics (Except where noted otherwise Ta=25°C, V_{DD}=3.3V)

Temperature - to - digital converter characteristics

Item	Symbol	Measurement conditions	Min.	Typ.	Max.	Units
Temperature detection accuracy *1	A _C	-25°C ≤ Ta ≤ 100°C			±2.0	°C
		-40°C ≤ Ta ≤ 125°C			±3.0	
Temperature data update time	T			2		ms
Supply current	I _{DD}	Normal operation		75	150	μA
		Shutdown mode		1		
O.S. output saturation voltage	V _S	I _{OUT} =4.0mA			0.4	V

Note : *1 The specification values of temperature detection accuracy show values when supply voltage is 3.3V. Temperature data vary by +1°C/V (typ.) against supply voltage.

Logic Electrical characteristics

Item	Symbol	Measurement conditions	Min.	Typ.	Max.	Units
Input voltage L	V _{IL}		0		0.7	V
Input voltage H	V _{IH}		2.1		V _{DD}	
SDA low level output voltage	V _{OL}	SDA sink 3mA	0.0		0.4	V
High level input current	I _{IH}	SDA, SCL=3.3V	-10		10	μA
Low level input current	I _{IL}	SDA, SCL=0.4V	-10		10	μA
Clock frequency	f _{SCL}				400	kHz
Data transfer wait time	t _{BUF}		1.3			μs
SCL start hold time	t _{HD;STA}		0.6			μs
SCL low level hold time	t _{LOW}		1.3			μs
SCL high level hold time	t _{HIGH}		0.6			μs
Start condition setup time	t _{SU;STA}		0.6			μs
SDA data hold time	t _{HD;DAT}		0			μs
SDA data setup time	t _{SU;DAT}		100			ns
SDA, SCL rise time	t _R				300	ns
SDA, SCL fall time	t _F				300	ns
Stop condition setup time	t _{SU;STO}		0.6			μs

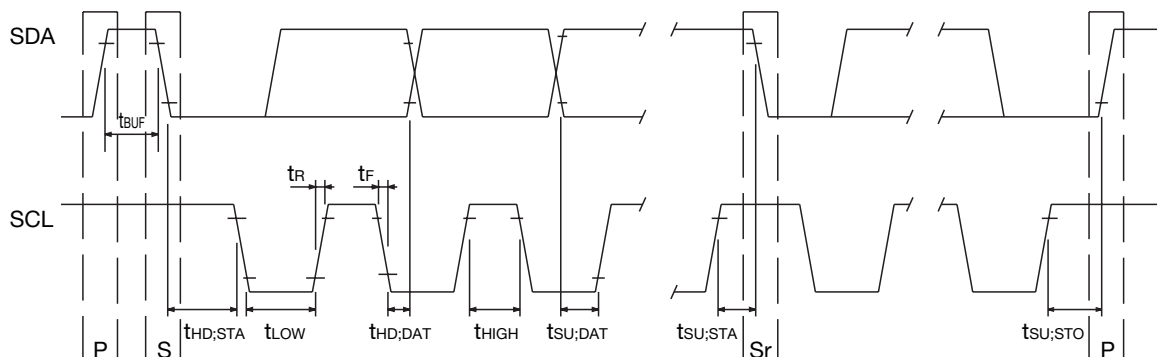

Measuring Circuit

Temperature data update time Supply current

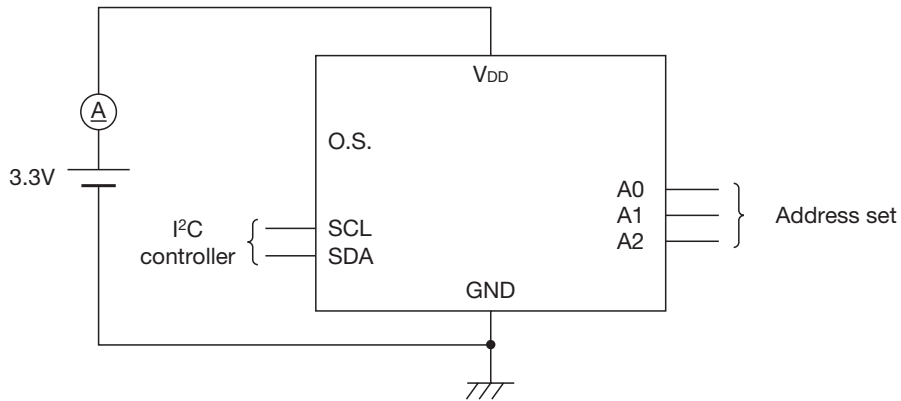

O.S. output saturation voltage

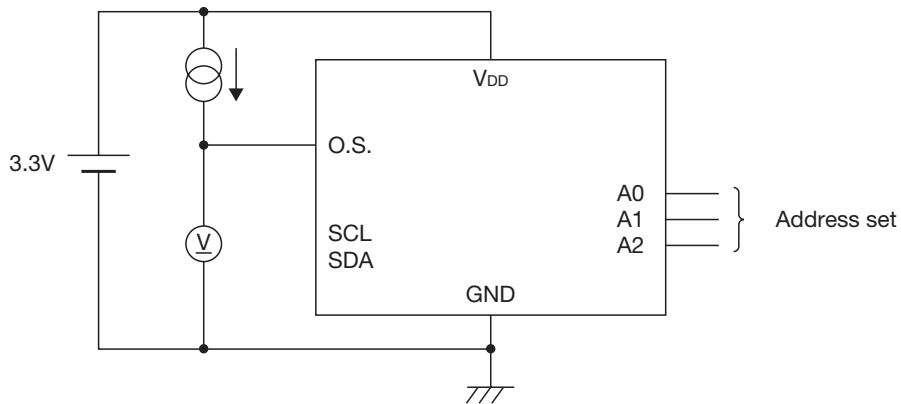

Application Circuit

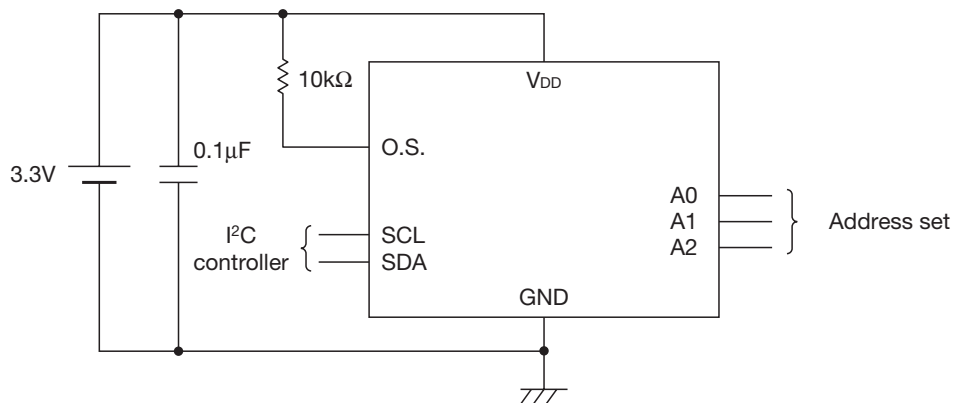

- Mitsumi shall not assume any liability for any accident or damage caused by use of this circuit.
- Mitsumi shall not assume any liability for any issues related to industrial property rights and/or other rights owned by third parties or shall not grant any license regarding use of this circuit.

I²C BUS

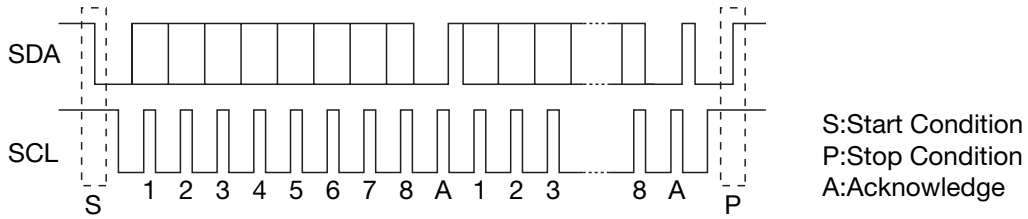

The bus system, I²C BUS is the system internal to the equipment, and is used to transfer the data with 2 lines, SDA and SCL. The data is transferred for every byte and at the end of every byte transfer the acknowledgment is inserted. The data transmit and receive are started with MSB first from Start condition.

MM3286 has a pointer register and 4 data registers that are selected with the pointer register.

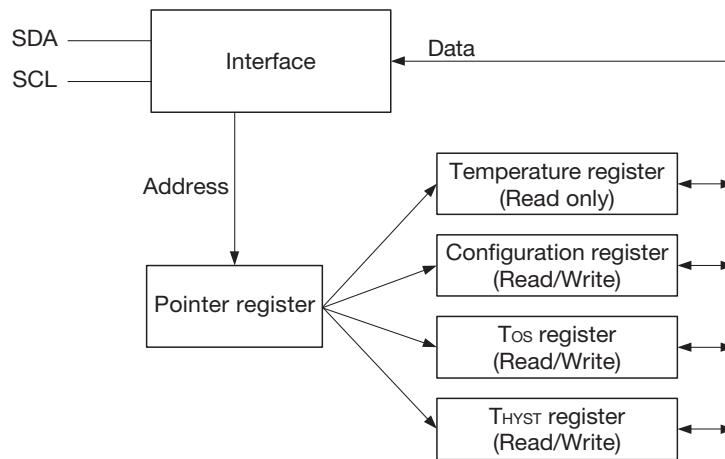

[I²C Data Format]

Read mode

In Temperature, Configuration, T_{OS} and T_{HYST} registers, data format in the Read mode is set up as shown below.

S	Slave address							R/W	A	DATA1								A	DATA2								P
	1	0	0	1	A2	A1	A0	1		D15	D14	D13	D12	D11	D10	D9	D8		D7	D6	D5	D4	D3	D2	D1	D0	
Address byte									Data byte								Data byte										

*When the selected register is the Configuration register, the data byte is 1byte only.

Write mode

In Configuration, T_{OS} and T_{HYST} registers, data format in the Write mode is set up as shown below.

S	Slave address							R/W	A	Pointer Register								A
	1	0	0	1	A2	A1	A0	0		0	0	0	0	0	0	D2	D1	
Address byte									Pointer byte									

DATA1								A	DATA2								P
D15	D14	D13	D12	D11	D10	D9	D8		D7	D6	D5	D4	D3	D2	D1	D0	
Data byte									Data byte								

* When the Configuration register is selected with the pointer byte, the data byte is 1byte only.

• Any products mentioned in this catalog are subject to any modification in their appearance and others for improvements without prior notification.
• The details listed here are not a guarantee of the individual products at the time of ordering. When using the products, you will be asked to check their specifications.

[Register construction]

Pointer register

P7	P6	P5	P4	P3	P2	P1	P0
0	0	0	0	0	0	Selected register	

(1) P0-P1: Register selection

P1	P0	Selected register
0	0	Temperature register (Read only, Default setup when power is injected.)
0	1	Configuration register (Read/Write)
1	0	T _{HYST} register (Read/Write)
1	1	T _{OS} register (Read/Write)

(2) P2-P7: Set and fix 0 in these bits.

Temperature register (Read only)

D15	D14	D13	D12	D11	D10	D9	D8	D7	D6	D5	D4	D3	D2	D1	D0
MSB	Bit7	Bit6	Bit5	Bit4	Bit3	Bit2	Bit1	LSB	X	X	X	X	X	X	X

(1) D0-D6: Undefined bits

(2) D7-D15: Temperature data bits. Temperature is expressed with two's complement where 1 LSB is 0.5°C.

Configuration register (Read Write)

D7	D6	D5	D4	D3	D2	D1	D0
0	0	0	Setup of the number of O.S. detection	Selection of O.S. polarity	Selection of O.S. mode	Selection of shutdown mode	

(1) D0: Selection of shutdown mode

D0	Shutdown mode
0	Normal operation
1	Shutdown

(2) D1: Selection of O.S. mode

D1	O.S. mode
0	Comparator mode
1	Latch mode

(3) D2: Selection of O.S. polarity

D2	O.S. polarity
0	Active Low
1	Active High

(4) D3-D4: Setup of the number of O.S. detection

D4	D3	Number of O.S. detection
0	0	1
0	1	2
1	0	4
1	1	6

(5) D2-D7: Retain 0 in these bits during the normal operation.

*The default value at the time of power injection is 0 for all the bits from D0 to D7.

T_{OS} and T_{HYST} registers (Read/Write)

D15	D14	D13	D12	D11	D10	D9	D8	D7	D6	D5	D4	D3	D2	D1	D0
MSB	Bit7	Bit6	Bit5	Bit4	Bit3	Bit2	Bit1	LSB	X	X	X	X	X	X	X

(1) D0-D6: Undefined bits

(2) D7-D15: Data bits for setting up temperature

*The default value at the time of power injection is 80°C for T_{OS} (T_{OS}=80°C) and 75°C for T_{HYST} (T_{HYST}=75°C).

Functional Descriptions

[Temperature Data Format]

Temperature data has a resolution of 9 bits (8 bits and 1 sign), 1LSB of which is 0.5°C, and is expressed with two's complement.

Temperature	Digital output	
	Binary code	Hex
+125°C	0 1111 1010	0FAh
+100°C	0 1100 1000	0C8h
+80°C	0 1010 0000	0A0h
+60°C	0 0111 1000	078h
+40°C	0 0101 0000	050h
+25°C	0 0011 0010	032h
+0.5°C	0 0000 0001	001h
0°C	0 0000 0000	000h
-0.5°C	1 1111 1111	1FFh
-10°C	1 1110 1100	1ECh
-25°C	1 1100 1110	1CEh
-40°C	1 1011 0000	1B0h

[O.S Output Temperature Detection Function]

Temperature detection function of O.S. output has 2 modes, Comparator mode and Latch mode. Output polarity in any mode has 2 types, Active Low (default type) and Active High. In order to avoid false detection of temperature, the number of temperature detection is selectable, where the maximum number is 6.

Mode, polarity and number of detections of O.S. output are selectable with the Configuration register.

Comparator mode

In the Comparator mode, the O.S. output becomes active when temperature is T_{OS} or more and it becomes inactive when temperature is T_{HYST} or less.

Latch mode

The O.S output becomes active when temperature is T_{OS} or more and remains active until it is reset. The reset condition is to read out temperature into any one of registers or to select the shutdown mode. When the output becomes active due to temperature exceeding T_{OS} and then it is reset, it is necessary for the output to become active again that temperature should be T_{HYST} or less.

Temperature detection operation timing chart

The next chart illustrates the timing of temperature detection operation when the O.S polarity is in the Active Low mode. In the Active High mode, the polarity is inverted but operations are same as they are in the Active Low mode.

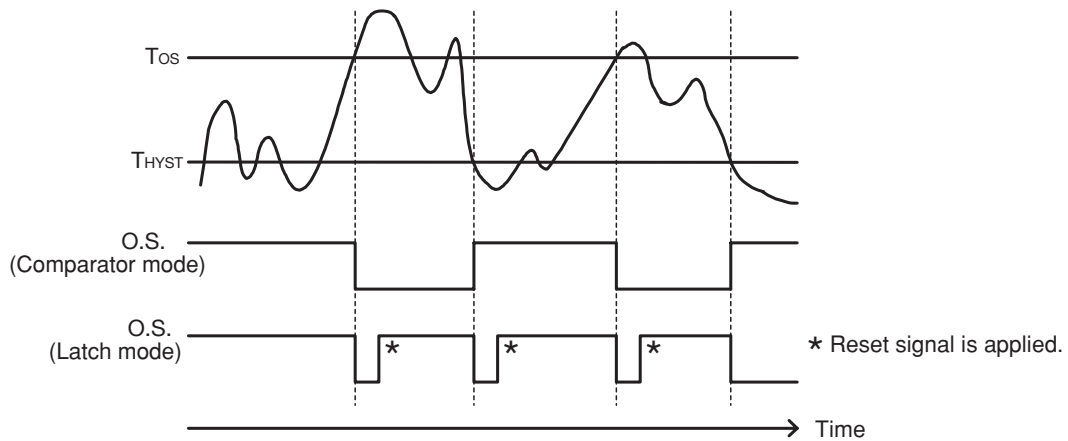

Number of detections

In order to avoid faulty detection in noisy environment, it is possible to set multiple numbers of detections of the O.S. output. With this function, the O.S. output is determined after detecting temperature for this preset number of times. In other words, the active status of O.S. output changes only when all the temperature detected for the preset number of times are T_{OS} or more, or when temperature detected for the preset number of times are T_{HYST} or less. The active status does not change in other cases than the above. The number of detections can be selectable with the Configuration register from 1, 2, 4, and 6.

[Shutdown mode]

The shutdown mode becomes active by setting 1 in the shutdown mode selection bit in the Configuration register. In the shutdown mode, the consumption current is typically 1 μ A to allow the power consumption in the standby mode to be reduced. Note that even in the shutdown mode it is possible to set up T_{OS} and T_{HYST} and to read the data from or write the data in the Configuration register.

Characteristics

Ambient temperature - accuracy

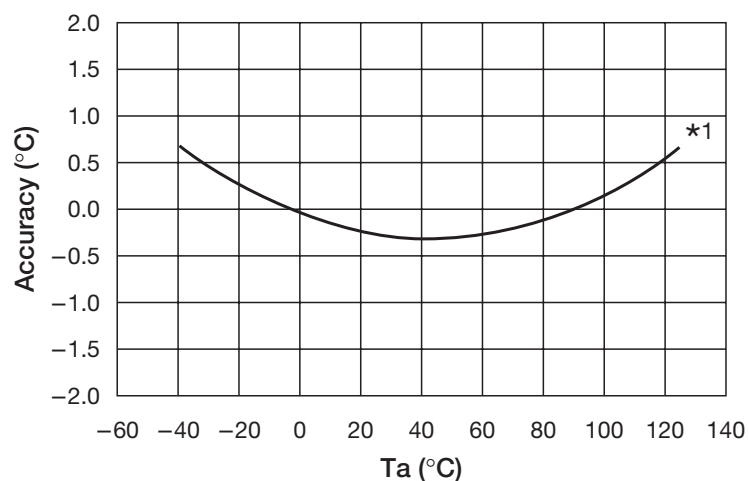

Note : *1 The characteristics graph shows an approximate curved line.

Ambient temperature - supply current

