

Low-Saturation 300mA Regulators

Monolithic IC MM168□□ Series

Outline

This IC is low saturation regulator IC with 300mA output realizing low current consumption, low noise, and high ripple rejection. The output capacitor is a ceramic capacitor, and the IC has the pin to reduce noise and control ON/OFF.

Features

- | | |
|---------------------------------|------------------------------------|
| 1. Low current consumption | 85μA typ. |
| 2. High accuracy output voltage | ±1.5% |
| 3. Dropout voltage | 0.12V typ. (I _o =150mA) |
| 4. High ripple rejection | 70dB typ. |
| 5. Operating temperature range | −30 to +85°C |
| 6. Output voltage | 1.5 to 5.2V (0.1V steps) |
| 7. Output capacitor | 1μF (Ceramic) |

Packages

- SOP-8D/G
- SOT-25A

Applications

- Constant voltage power supplies for battery-powered device
- Constant voltage sources for portable communication equipment
- Constant voltage sources for home appliances

Pin Assignment

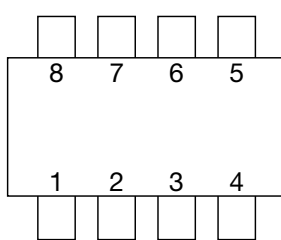

SOP-8D/G
(TOP VIEW)

1	V _{OUT}
2	NC
3	C _n
4	GND
5	CONT
6	NC
7	NC
8	V _{IN}

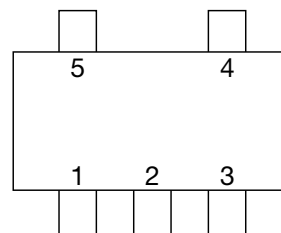

SOT-25A
(TOP VIEW)

1	V _{IN}
2	GND
3	CONT
4	Noise
5	V _{OUT}

R No. table

Taping: R housing

Parts No.	Vo (V)	R No. (R59)	Parts No.	Vo (V)	R No. (R59)
MM1681FFBE	1.5	1499	MM1683EFBE	3.4	1521
MM1681GFBE	1.6	1500	MM1683FFBE	3.5	1522
MM1681HFBE	1.7	1501	MM1683GFBE	3.6	1523
MM1681JFBE	1.8	1502	MM1683HFBE	3.7	1524
MM1681KFBE	1.9	1503	MM1683JFBE	3.8	1525
MM1682AFBE	2.0	1504	MM1683KFBE	3.9	1526
MM1682BFBE	2.1	1505	MM1684AFBE	4.0	1527
MM1682CFBE	2.2	1506	MM1684BFBE	4.1	1528
MM1682DFBE	2.3	1507	MM1684CFBE	4.2	1529
MM1682EFBE	2.4	1508	MM1684DFBE	4.3	1530
MM1682FFBE	2.5	1509	MM1684EFBE	4.4	1531
MM1682GFBE	2.6	1510	MM1684FFBE	4.5	1532
MM1682HFBE	2.7	1511	MM1684GFBE	4.6	1533
MM1682JFBE	2.8	1512	MM1684HFBE	4.7	1534
MM1682KFBE	2.9	1513	MM1684JFBE	4.8	1535
MM1683AFBE	3.0	1514	MM1684KFBE	4.9	1536
MM1683BFBE	3.1	1515	MM1685AFBE	5.0	1537
MM1683CFBE	3.2	1518	MM1685BFBE	5.1	1538
MM1683DFBE	3.3	1519	MM1685CFBE	5.2	1539

Block Diagram

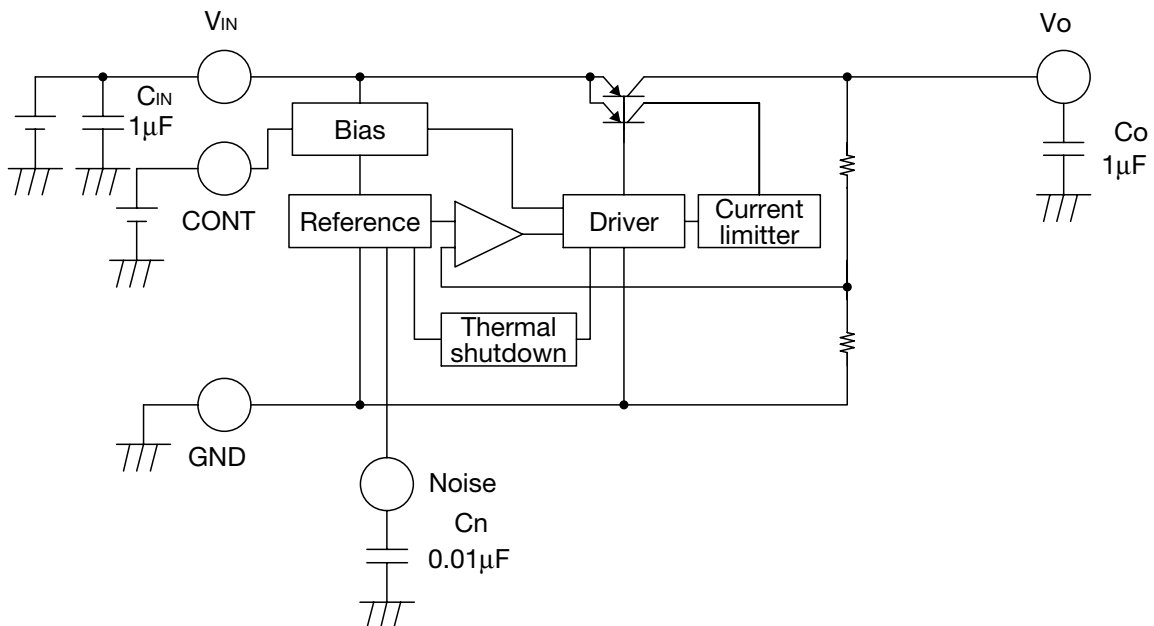

• Any products mentioned in this catalog are subject to any modification in their appearance and others for improvements without prior notification.
 • The details listed here are not a guarantee of the individual products at the time of ordering. When using the products, you will be asked to check their specifications.

Pin Description SOP-8D/G

Pin No.	Pin name	Function	Internal equivalent circuit diagram			
1	V _{OUT}	Output pin The capacitor must be connected with output pin more than 1μF.				
2	NC	No connection				
3	Cn	Noise decrease pin Connecting 0.01μF capacitor can decrease output noise. If the noise decrease capacitor is not connected, the pin may be influenced by outside noise.				
4	GND	Ground				
5	CONT	ON/OFF Control pin <table border="1" style="margin: 0 auto;"> <tr><td>CONT</td></tr> <tr><td>H</td></tr> <tr><td>L</td></tr> </table> CONT pin must be connected with V _{IN} pin, if it is not used.	CONT	H	L	
CONT						
H						
L						
6	NC	No connection				
7	NC	No connection				
8	V _{IN}	Input pin The capacitor is required to connect with input pin more than 1μF.				

Absolute Maximum Ratings (Ta=25°C)

Item	Symbol	Ratings	Units
Storage temperature	T _{STG}	-400~+150	°C
Operating temperature	T _{OPR}	-300~+85	°C
Supply voltage	V _{IN}	-0.30~+12	V
Output current	I _{OUT}	400	mA
Power dissipation	P _d	950 (*1)	mW

Note1: *1 With the double sided PC Board of glass epoxy. (Copper plane 80%, 192×142×1.2mm)

• Any products mentioned in this catalog are subject to any modification in their appearance and others for improvements without prior notification.
 • The details listed here are not a guarantee of the individual products at the time of ordering. When using the products, you will be asked to check their specifications.

Recommended Operating Conditions

Item	Symbol	Ratings	Units
Output current	I_{OUT}	0~300	mA
Operating voltage	V_{OP}	2.2~12	V

Electrical Characteristics 1 (Except where noted otherwise, $T_a=25^\circ\text{C}$, $V_{IN}=V_o$ (Typ.) +1V, $I_o=1\text{mA}$, $V_{CONT}=1.6\text{V}$)

Item	Symbol	Measurement conditions	Min.	Typ.	Max.	Units
No-Load input current	I_{CC}	$I_o=0\text{mA}$		85	140	μA
Input current (OFF)	I_{CCOFF}	$V_{CONT}=0\text{V}$		0	0.1	μA
Output voltage *2	V_{OUT}	$I_o=1\text{mA}$	$\times 0.985$		$\times 1.015$	V
Dropout voltage *3	V_{IO}	$V_{IN}=V_o-0.2\text{V}$, $I_o=150\text{mA}$		0.12	0.24	V
Line regulation	ΔV_1	$V_{IN}=V_o+1.5\sim V_o+2.5\text{V}$, $I_o=1\text{mA}$		10	20	mV
Load regulation	ΔV_2	$I_o=0\sim 300\text{mA}$		15	60	mV
V_{OUT} temperature coefficient *1	$\Delta V_{OUT}/\Delta T$	$T_j=-40\sim +85^\circ\text{C}$		± 100		ppm/ $^\circ\text{C}$
Ripple rejection *1	RR	$f=120\text{Hz}$ $V_{ripple}=1\text{V}$, $I_o=100\text{mA}$	50	70		dB
Output noise voltage *1	V_n	$f_{BW}=20\sim 80\text{kHz}$, $C_n=0.01\mu\text{F}$, $I_{OUT}=100\text{mA}$		30		μV_{rms}
		$f_{BW}=20\sim 80\text{kHz}$, $C_n=OPEN$, $I_{OUT}=100\text{mA}$		150		
CONT pin input current	I_{CONT}		10	20	30	μA
CONT pin high threshold level	V_{CONTH}		1.6		$V_{IN}+0.3$	V
CONT pin low threshold level	V_{CONTL}		-0.3		0.4	V

Note 1: *1 The parameter is guaranteed by design.

Note 2: *2 Please refer to Electrical Characteristics 2.

Note 3: *3 The parameter is not guaranteed in the model less than $V_{OUT}=2\text{V}$.

Electrical Characteristics 2 (Except where noted otherwise, Ta=25°C, VIN=Vo (Typ.)+1V, Io=1mA, VCONT=1.6V)

Output Voltage

Model No.	Test conditions	Output voltage		
		Min.	Typ.	Max.
MM1681F	Io=1mA	1.478	1.5	1.523
MM1681G		1.576	1.6	1.624
MM1681H		1.675	1.7	1.726
MM1681J		1.773	1.8	1.827
MM1681K		1.872	1.9	1.929
MM1682A		1.970	2.0	2.030
MM1682B		2.069	2.1	2.132
MM1682C		2.167	2.2	2.233
MM1682D		2.266	2.3	2.335
MM1682E		2.364	2.4	2.436
MM1682F		2.463	2.5	2.538
MM1682G		2.561	2.6	2.639
MM1682H		2.660	2.7	2.741
MM1682J		2.758	2.8	2.842
MM1682K		2.857	2.9	2.944
MM1683A		2.955	3.0	3.045
MM1683B		3.054	3.1	3.147
MM1683C		3.152	3.2	3.248
MM1683D		3.251	3.3	3.350
MM1683E		3.349	3.4	3.451
MM1683F	3.448	3.5	3.553	
MM1683G	3.546	3.6	3.654	

Model No.	Test conditions	Output voltage		
		Min.	Typ.	Max.
MM1683H	Io=1mA	3.645	3.7	3.756
MM1683J		3.743	3.8	3.857
MM1683K		3.842	3.9	3.959
MM1684A		3.940	4.0	4.060
MM1684B		4.039	4.1	4.162
MM1684C		4.137	4.2	4.263
MM1684D		4.236	4.3	4.365
MM1684E		4.334	4.4	4.466
MM1684F		4.433	4.5	4.568
MM1684G		4.531	4.6	4.669
MM1684H		4.630	4.7	4.771
MM1684J		4.728	4.8	4.872
MM1684K		4.827	4.9	4.974
MM1685A		4.925	5.0	5.075
MM1685B		5.024	5.1	5.177
MM1685C		5.122	5.2	5.278

Measuring Circuit

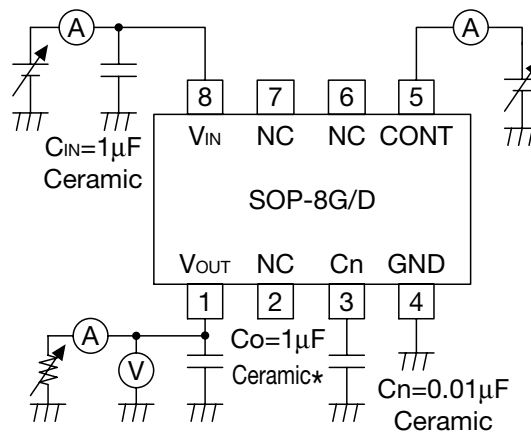

*Temperature Characteristics: B Type

• Any products mentioned in this catalog are subject to any modification in their appearance and others for improvements without prior notification.
 • The details listed here are not a guarantee of the individual products at the time of ordering. When using the products, you will be asked to check their specifications.

Application Circuit

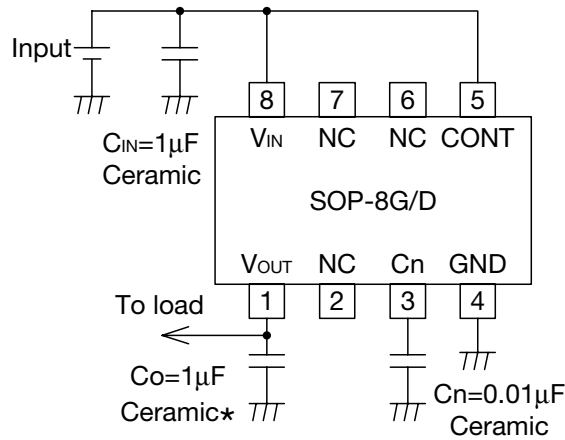

*Temperature Characteristics: B Type

Note

1. The output capacitor is required between output and GND to prevent oscillation.
2. The output capacitor must be used in ESR stable area.
It is possible to use a ceramic capacitor without ESR resistance for output.
The ceramic capacitor must be more than 1µF with B type temperature characteristics.
3. The wire of V_{CC} and GND is required to print full ground plane for noise and stability.
4. The input capacitor must be connected in 1cm from input pin.
5. When the output voltage oversteps the input voltage, the overcurrent can flow by internal parasitic diode. In such application, the external bypass diode must be connected between output and input pin.

Characteristics ($V_o=2.8V$ Except where noted otherwise, $T_a=25^\circ C$, $V_{IN}=V_o+1V$, $V_{CONT}=2V$, $C_{IN}=1\mu F$, $C_o=1\mu F$, $C_n=0.01\mu F$)

Output-Input Voltage

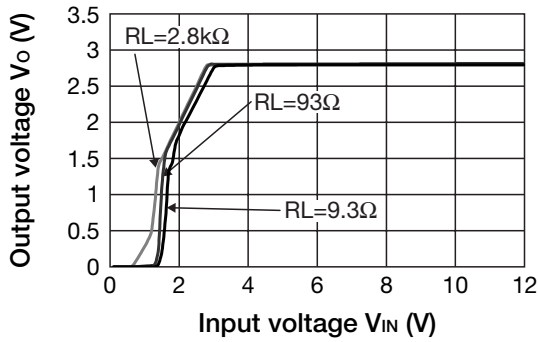

Input Current-Input Voltage

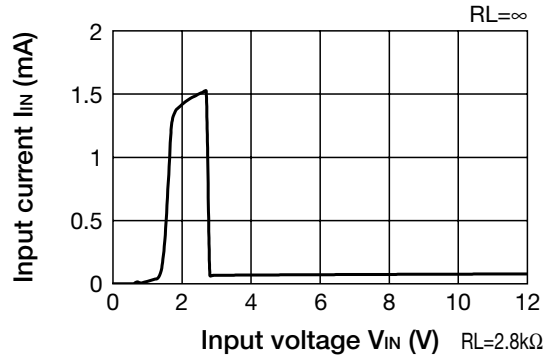

Load Regulation

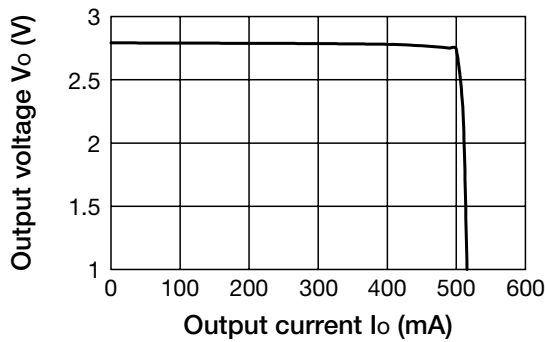

Line Regulation

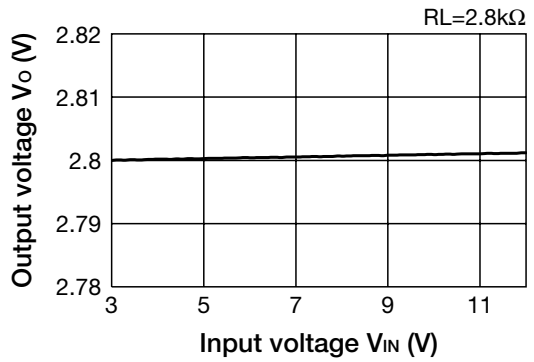

Dropout Voltage

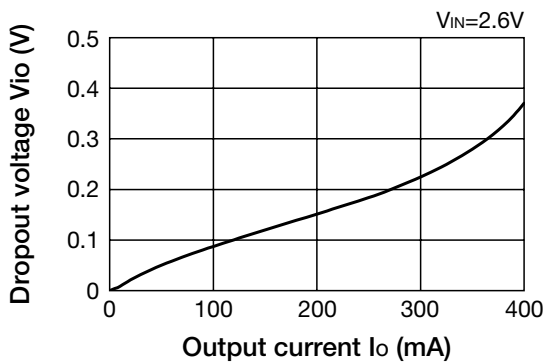

Output Voltage- Ambient Temperature

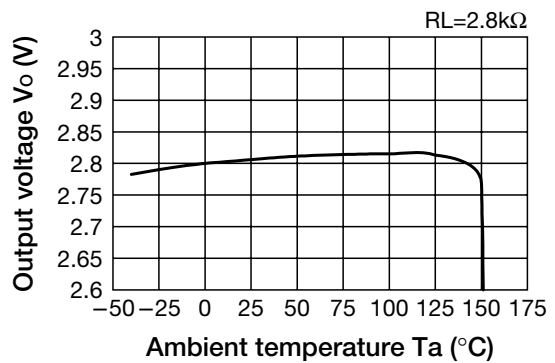

• Any products mentioned in this catalog are subject to any modification in their appearance and others for improvements without prior notification.
 • The details listed here are not a guarantee of the individual products at the time of ordering. When using the products, you will be asked to check their specifications.

Characteristics ($V_o=2.8V$ Except where noted otherwise, $T_a=25^\circ C$, $V_{in1}=V_o+1V$, $V_{cont}=2V$, $C_{in}=1\mu F$, $C_o=1\mu F$, $C_n=0.01\mu F$)

Ripple Rejection

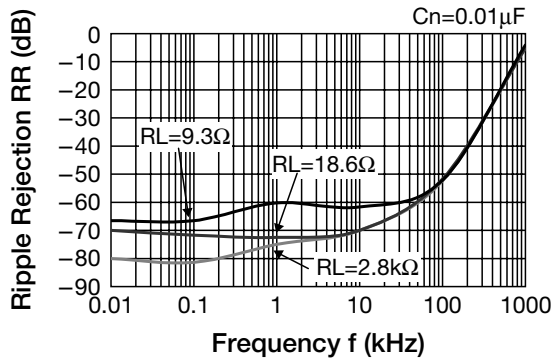

Ripple Rejection

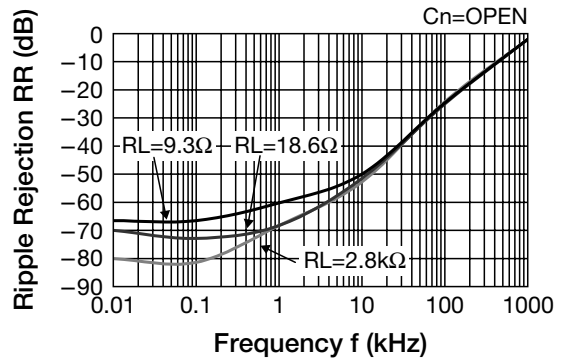

GND Pin Current

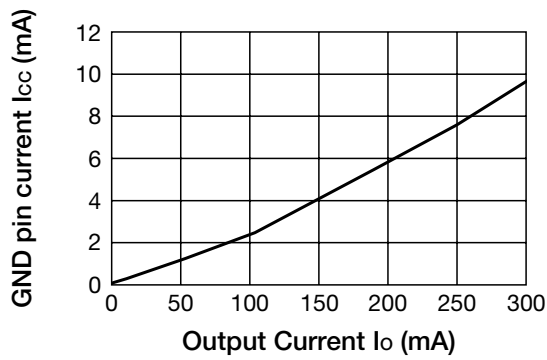

Output Noise Voltage

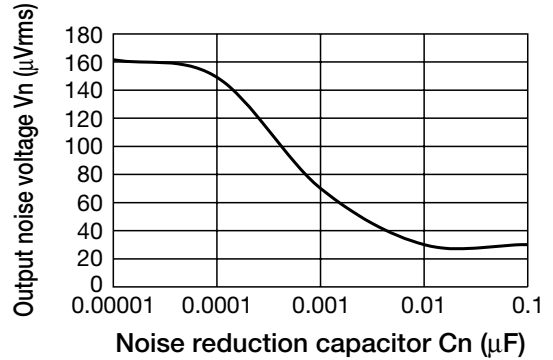

ESR Stability Area

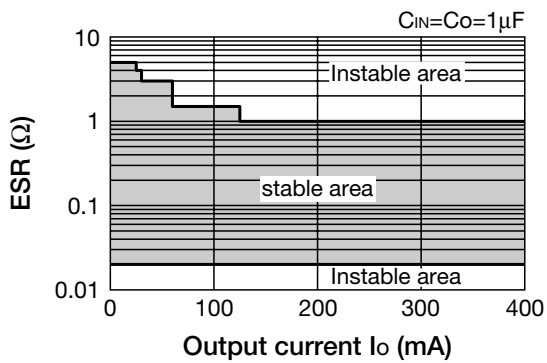

ESR Stability Area

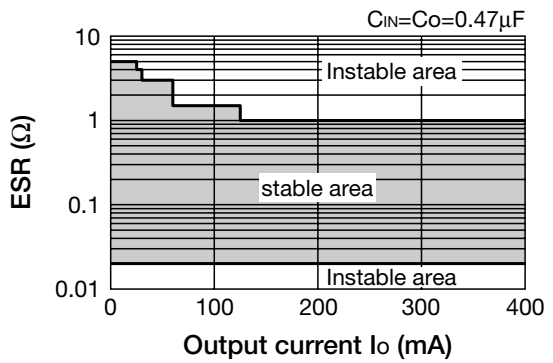

• Any products mentioned in this catalog are subject to any modification in their appearance and others for improvements without prior notification.
 • The details listed here are not a guarantee of the individual products at the time of ordering. When using the products, you will be asked to check their specifications.

Characteristics ($V_o=2.8V$ Except where noted otherwise, $T_a=25^\circ C$, $V_{IN1}=V_o+1V$, $V_{CONT}=2V$, $C_{IN}=1\mu F$, $C_o=1\mu F$, $C_n=0.01\mu F$)

Load Transient Responses ($I_o=0 \rightarrow 300mA$)

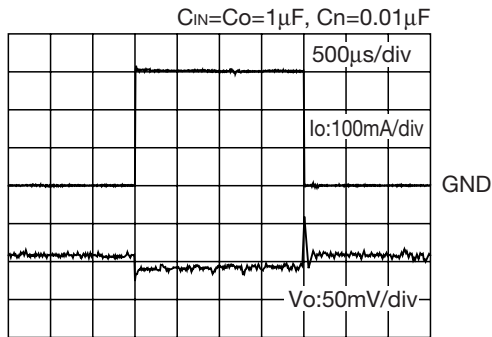

Load Transient Responses ($I_o=0 \rightarrow 300mA$)

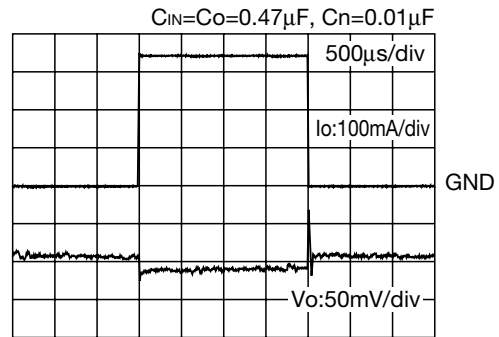

Line Transient Responses ($V_{IN}=3.8 \rightarrow 4.8V$, $I_o=30mA$)

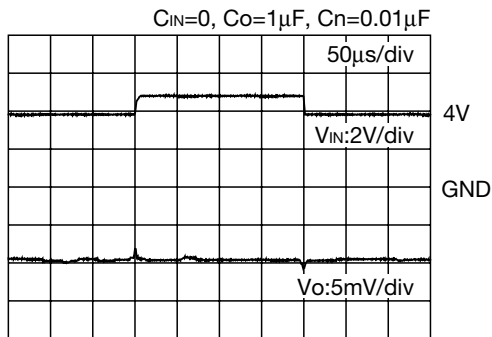

Line Transient Responses ($V_{IN}=3.8 \rightarrow 4.8V$, $I_o=30mA$)

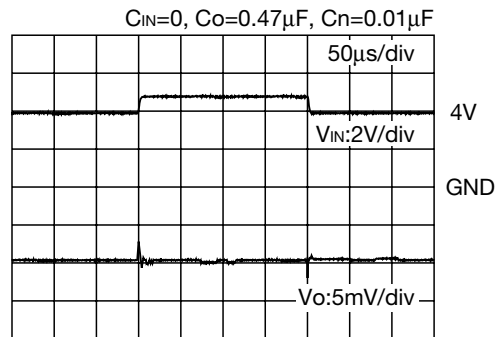

Turn-On Transient Responses

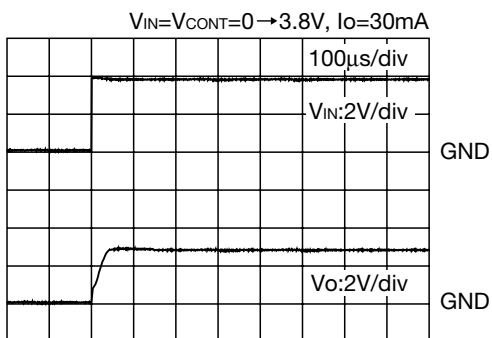

Turn-On Transient Responses

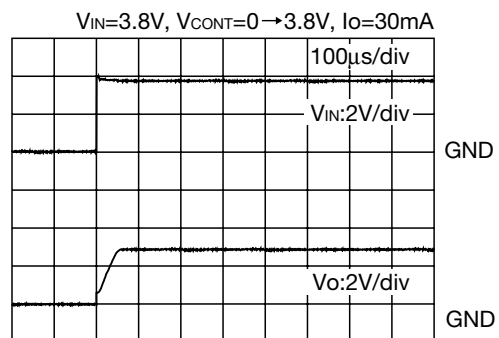

• Any products mentioned in this catalog are subject to any modification in their appearance and others for improvements without prior notification.
• The details listed here are not a guarantee of the individual products at the time of ordering. When using the products, you will be asked to check their specifications.

Characteristics ($V_o=1.8V$ Except where noted otherwise, $T_a=25^\circ C$, $V_{in1}=V_o+1V$, $V_{cont}=2V$, $C_{in}=1\mu F$, $C_o=1\mu F$, $C_n=0.01\mu F$)

Output-Input Voltage

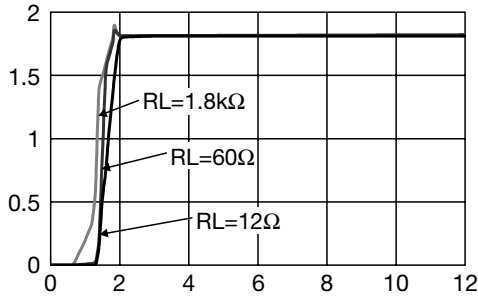

Load Regulation

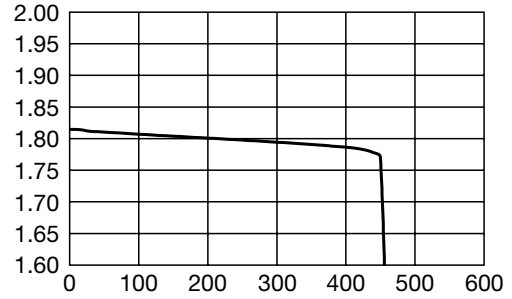

Line Regulation

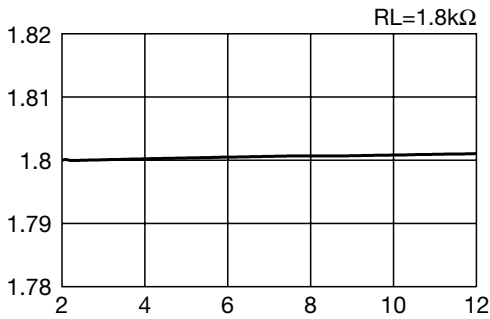

Output Voltage- Ambient Temperature

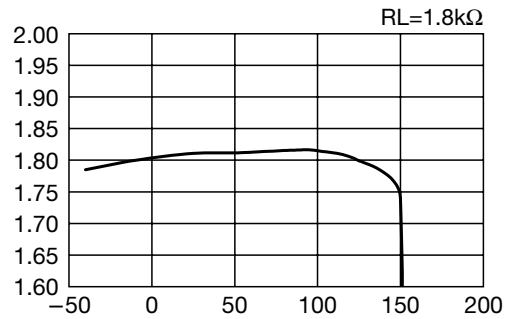

ESR Stability Area

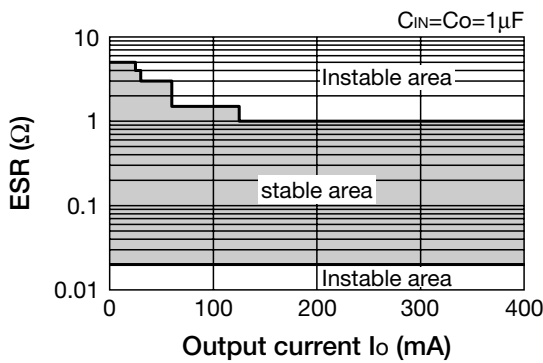

ESR Stability Area

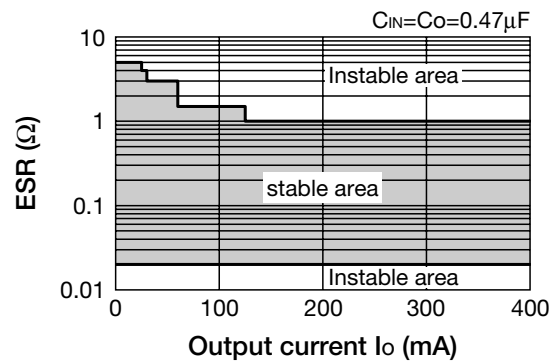

• Any products mentioned in this catalog are subject to any modification in their appearance and others for improvements without prior notification.
 • The details listed here are not a guarantee of the individual products at the time of ordering. When using the products, you will be asked to check their specifications.

Characteristics ($V_o=3.3V$ Except where noted otherwise, $T_a=25^\circ C$, $V_{IN1}=V_o+1V$, $V_{CONT}=2V$, $C_{IN}=1\mu F$, $C_o=1\mu F$, $C_n=0.01\mu F$)

Output-Input Voltage

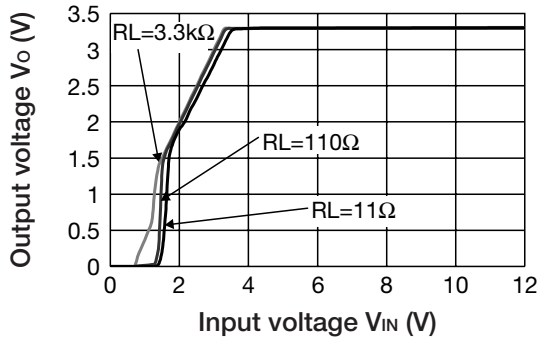

Load Regulation

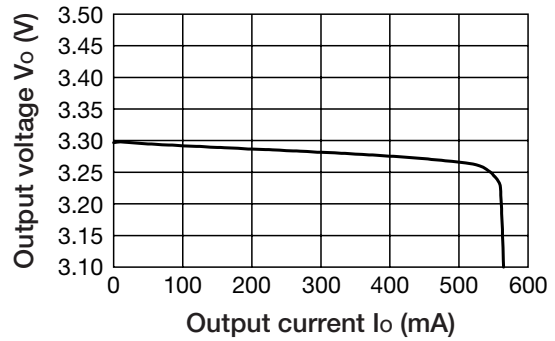

Line Regulation

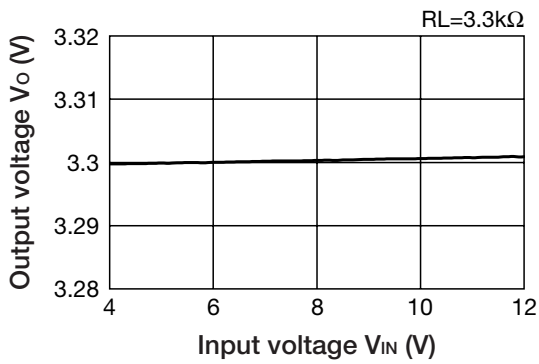

Output Voltage- Ambient Temperature

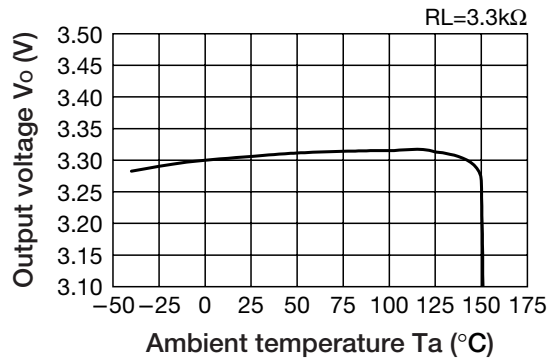

ESR Stability Area

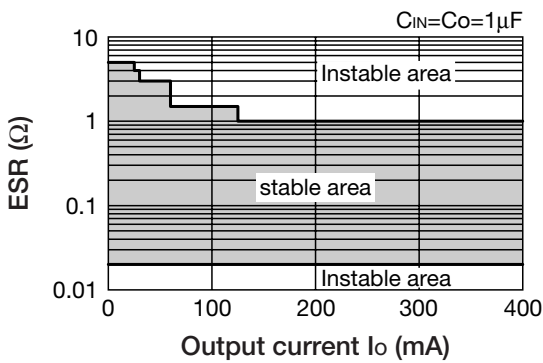

ESR Stability Area

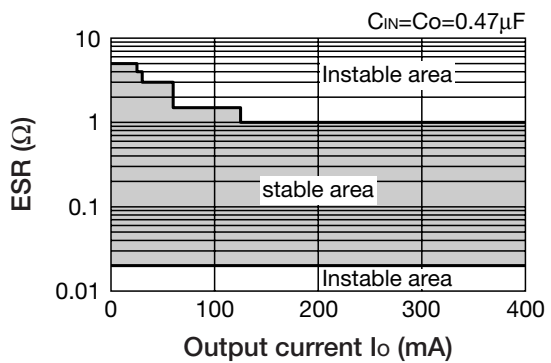

• Any products mentioned in this catalog are subject to any modification in their appearance and others for improvements without prior notification.
 • The details listed here are not a guarantee of the individual products at the time of ordering. When using the products, you will be asked to check their specifications.