

Packing

SOP, SSOP

Models used	Maximum number stored
SOP-7A	75/magazine
SOP-8A	75/magazine

Units : mm

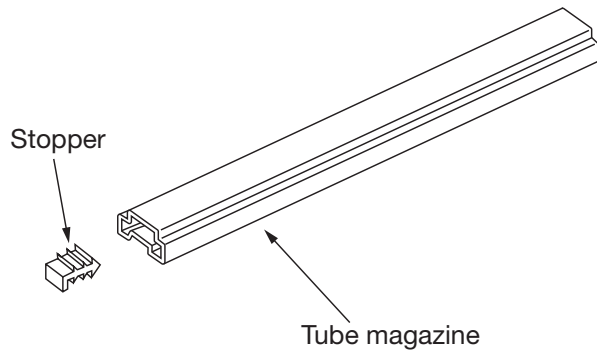
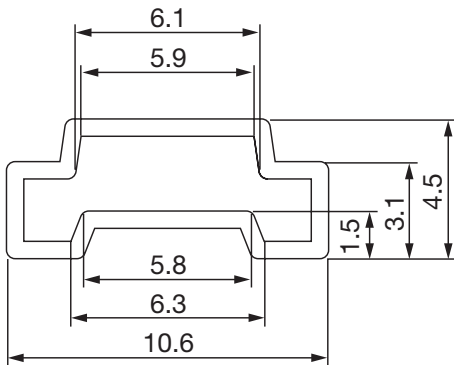

Tube magazine sheet thickness: 0.5
 Length: 500
 Material: Transparent PVC
 (treated to prevent charge buildup)

Models used	Maximum number stored
SOP-8B	90/magazine

Units : mm

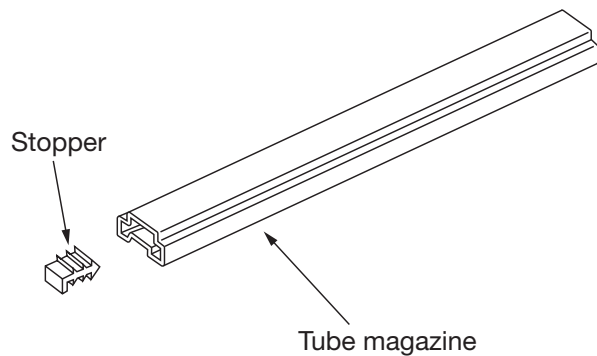
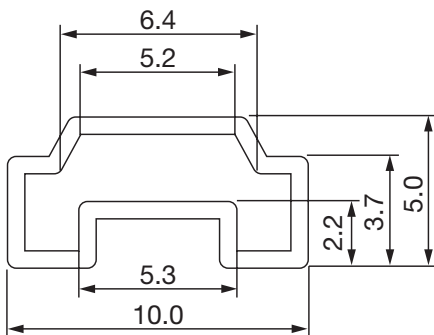

Tube magazine sheet thickness: 0.6
 Length: 515
 Material: Transparent PVC
 (treated to prevent charge buildup)

Packing

Models used	Maximum number stored
SOP-8C	50/magazine
SOP-8E	50/magazine
SOP-14B	25/magazine
SOP-16B	25/magazine
SSOP-16A	25/magazine

Units : mm

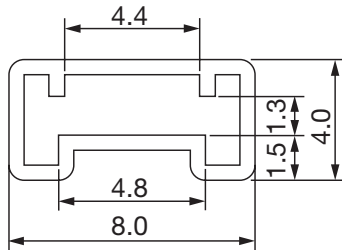

Stopper

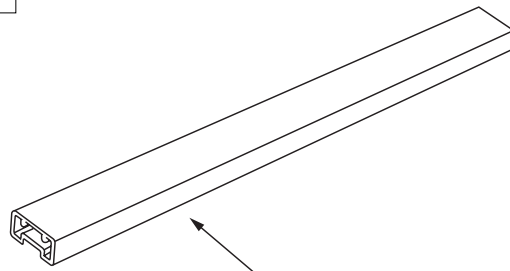

Tube magazine

Tube magazine sheet thickness: 0.5

Length: 280.5

Material: Transparent PVC
(treated to prevent charge buildup)

Models used	Maximum number stored
SOP-14A	50/magazine
SOP-16A	50/magazine

Units : mm

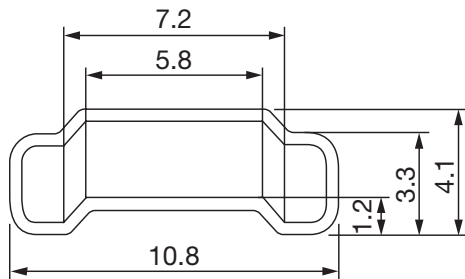

Stopper

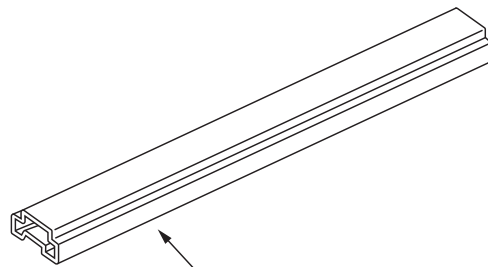

Tube magazine

Tube magazine sheet thickness: 0.4

Length: 525

Material: Transparent PVC
(treated to prevent charge buildup)

Packing

Models used	Maximum number stored
SOP-18A	25/magazine
SOP-20B	25/magazine
SOP-22A	25/magazine
SOP-24A	25/magazine
SSOP-20A	25/magazine
SSOP-24A	25/magazine

Units : mm

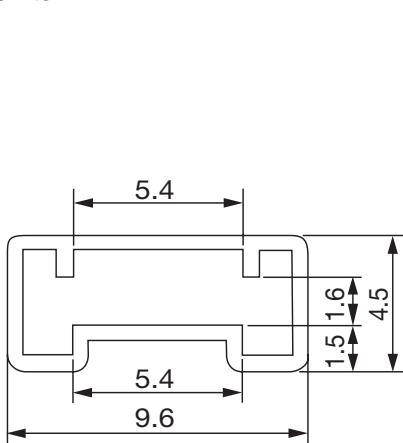

Stopper

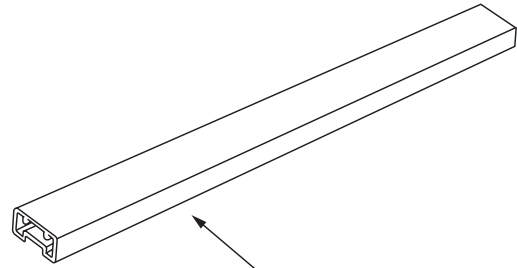

Tube magazine

Tube magazine sheet thickness: 0.5

Length: 400

Material: Transparent PVC
(treated to prevent charge buildup)

Models used	Maximum number stored
SOP-28A	25/magazine

Units : mm

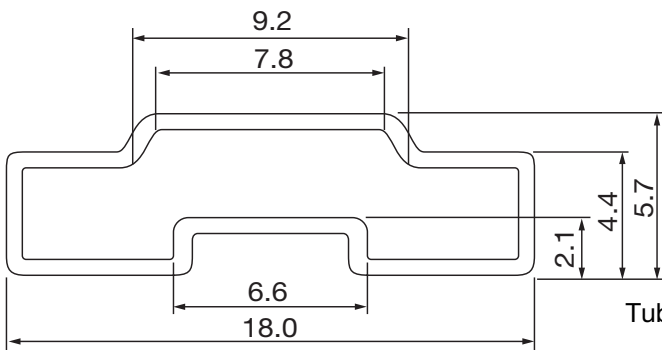

Stopper

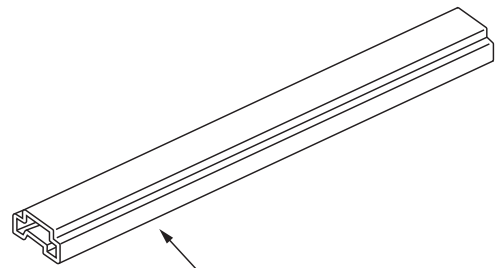

Tube magazine

Tube magazine sheet thickness: 0.6

Length: 480

Material: Transparent PVC
(treated to prevent charge buildup)

Packing

Models used	Maximum number stored
SOP-28B	25/magazine

Units : mm

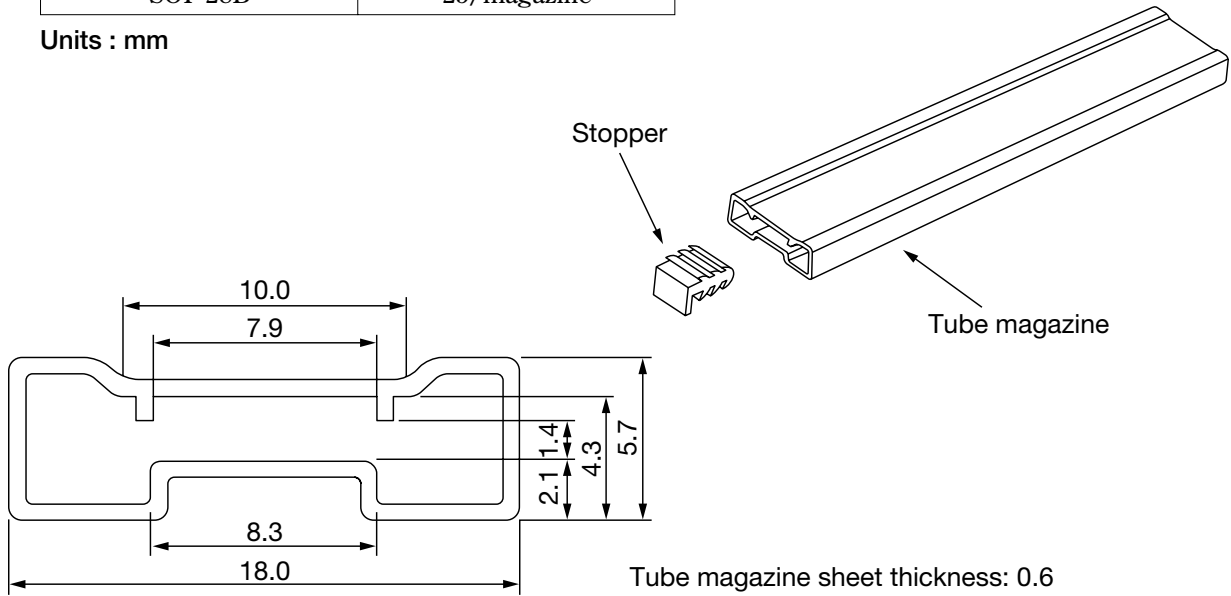

Tube magazine sheet thickness: 0.6

Length: 480

Material: Transparent PS
(treated to prevent charge buildup)