

Q Xpander Processors

Monolithic IC MM1434

Outline

From ordinary stereo signal input, each of the sound sources is expanded spatially to reproduce sound with a sense of immediacy.

Algorithms developed by Q Sound are faithfully implemented in an IC produced by Mitsumi.

Features

1. Sound spreading is easily modified using an external VR.
2. Few external components required through use of active filters based on Mitsumi's bipolar technology.
3. Low cost achieved through improvements from previous model (MM1354) to VA.

Package

SOP-16A (MM1434XFBE)

Applications

Sound enhancement processor.

Pin Assignment

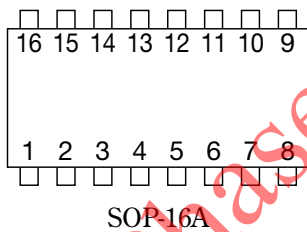

1	R _{IN}	9	L _{OUT}
2	VREF	10	DET
3	S/Q	11	QF4
4	FC	12	QF3
5	SPC	13	QF2
6	Q _{IN}	14	QF1
7	R _{OUT}	15	L _{IN}
8	GND	16	V _{CC}

Block Diagram

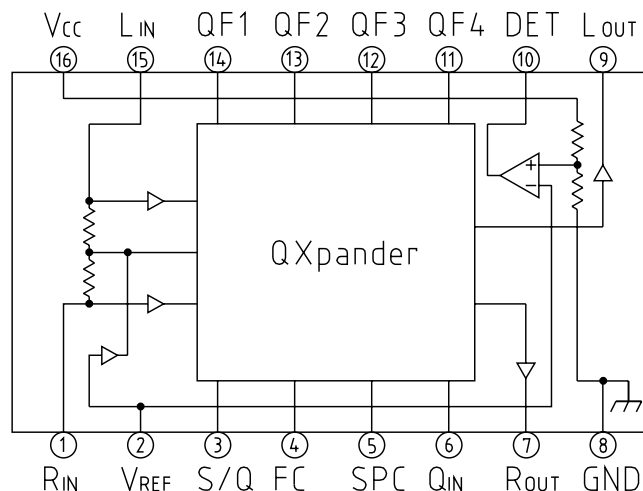

Pin Description

Pin No.	Pin name	Functions	Equivalent circuit diagram
1 15	R _{IN} L _{IN}	Input pin R Input pin L	
2	VREF	DC reference voltage pin	
3	S/Q	STEREO/Q Sound Switch pin	
4	FC	Filter frequency control pin	
5	SPC	Spread control pin	

Pin No.	Pin name	Functions	Equivalent circuit diagram
6	Q _{IN}	Q Sound input pin	
7 9	R _{OUT} L _{OUT}	Output pin R Output pin L	
8	GND	GND pin	
10	DET	Vcc off detect pin	
11 12 13 14	QF4 QF3 QF2 QF1	Filter pin Qf4 Filter pin Qf3 Filter pin Qf2 Filter pin Qf1	
16	V _{CC}	Supply voltage pin	

Absolute Maximum Ratings (Except where noted otherwise, Ta=25°C)

Item	Symbol	Ratings	Unit
Storage temperature	T _{STG}	-40~+125	°C
Operating temperature	T _{OPR}	-20~+75	°C
Power supply voltage	V _{CC} max.	12	V
Input voltage	V _{IN} max.	0 ≤ V _{IN} ≤ V _{CC}	V
Output current	I _o max.	10	mA
Allowable loss	P _d	350	mW

Recommended Operating Conditions

Item	Symbol	Ratings	Unit
Operating temperature	T _{OPR}	-20~+75	°C
Operating voltage Q Xpander(1)	V _{opq1}	3.8-9.0 R1=18kΩ*1	V
Operating voltage Q Xpander(2)	V _{opq2}	5.0-9.0 R1=22kΩ*1	V
Operating voltage bypass	V _{opb}	3.0~9.0	V

Note 1 : When R1 is chosen 22kΩ, the operating voltage Q Xpander becomes narrower. But the input dynamic range becomes wider. The character is illustrated in the typical performance characteristics (3).

Electrical Characteristics (Except where noted otherwise V_{cc}=8V, Ta=25°C, V_{byp}=5V, SW1, 2, 3, 4 : A R1=22kΩ)

Item	Symbol	Measurement conditions	Min.	Typ.	Max.	Unit
Consumption current	I _{cc}			16	22	mA
Voltage gain Q Xpander 1	G _{qx1}	SG1 : 0.5V _{rms} , 1kHz SW3 : B TP1	7.6	9.1	10.6	dB
Voltage gain Q Xpander 2	G _{qx2}	SG1 : 0.5V _{rms} , 1kHz SW3 : B TP2	4.1	5.6	7.1	dB
Voltage gain Q Xpander 3	G _{qx3}	SG2 : 0.5V _{rms} , 1kHz SW4 : B TP2	7.6	9.1	10.6	dB
Voltage gain Q Xpander 4	G _{qx4}	SG2 : 0.5V _{rms} , 1kHz SW4 : B TP1	4.1	5.6	7.1	dB
Voltage gain bypass 1	G _{by1}	SG1 : 0.5V _{rms} , 1kHz V _{byp} =0V SW3 : B TP1	-1	0	1	dB
Voltage gain bypass 2	G _{by2}	SG2 : 0.5V _{rms} , 1kHz V _{byp} =0V SW4 : B TP2	-1	0	1	dB
Input voltage (1)	V _{IN1}	V _{CC} =8V *1 SW3, 4 : B TP1, TP2	0.5	0.7		V _{rms}
Input voltage (2)	V _{IN2}	V _{CC} =3.8V R1=18kΩ *1 SW3, 4 : B TP1, TP2	0.15	0.25		V _{rms}
Input voltage (3)	V _{IN3}	V _{CC} =3V R1=18kΩ V _{byp} =0V *1 SW3, 4 : B TP1, TP2	0.3	0.45		V _{rms}
Input voltage (4)	V _{IN4}	V _{CC} =8V *2 SW3, 4 : B TP1, TP2	0.25	0.35		V _{rms}
Total harmonic distortion Q Xpander	THD _{qx}	(a) SG1 : 0.5V _{rms} , 1kHz SW3 : B (b) SG2 : 0.5V _{rms} , 1kHz SW4 : B TP1, TP2		0.4	1.0	%
Total harmonic distortion bypass	THD _{by}	(a) SG1 : 0.5V _{rms} , 1kHz SW3 : B (b) SG2 : 0.5V _{rms} , 1kHz SW4 : B V _{byp} =0V TP1, TP2		0.03	0.3	%
Output noise voltage Q Xpander	V _{noqx}	BW=20~20kHz, A Curve TP1, TP2		75	150	μV _{rms}
Output noise voltage bypass	V _{nobyp}	BW=20~20kHz, A Curve V _{byp} =0V TP1, TP2		15	60	μV _{rms}
R-L channel balance	C _b	SG1, SG2 : 0.5V _{rms} , 1kHz V _{byp} =0V SW3, 4 : B TP1, TP2	-1.0	0	1.0	dB

Item	Symbol	Measurement conditions	Min.	Typ.	Max.	Unit
Bypass pin voltage (H)	Vbyph	*3	2.1			V
Bypass pin voltage (L)	Vbypl	*4			0.7	V
Bypass pin current (H)	Ibyph	Vbyp=5V *5 TP5			350	μA
Bypass pin current (L)	Ibypl	Vbyp=0V *6 TP5	-10			μA
Recommended power supply off time	TvOFF	*7	0.1		1.0	s
DET terminal voltage (H)	Vdeth	*7 TP6	7.5			V
DET terminal voltage (L)	Vdetl	*7 TP6			0.7	V
VREF terminal current	Iref	SW2 : B	-2.2	-0.6	1	μA
Input resistance	R _{IN}	TP3, TP4	21	30	39	kΩ
Power supply ripple rejection ratio Q Xpander	PSRR _{qx}	SG3 : 50mVrms, 100Hz SW1 : B *8 TP1, TP2		-40	-30	dB
Power supply ripple rejection ratio bypass	PSRR _{by}	SG3 : 50mVrms, 100Hz SW1 : B *8 Vbyp=0V TP1, TP2		-55	-40	dB
Crosstalk (1)	Ct1	SG1 : 0.5Vrms, 1kHz SW3 : B *9 Vbyp=0V TP1, TP2		-85	-70	dB
Crosstalk (2)	Ct2	SG2 : 0.5Vrms, 1kHz SW4 : B *10 Vbyp=0V TP1, TP2		-85	-70	dB

Note 1 : f=1kHz, It is input voltage that THD of output voltage is 1%. Then the signals that are inputted in SG1 and SG2 are in phase. The difference of phase between the left input signal and the right one is 0°.

Note 2 : f=1kHz, It is input voltage that THD of output voltage is 1%. The difference of phase between the left input signal and the right one is 180°.

Note 3 : High-Level input voltage of BYP terminal (3pin) (Q Xpander MODE)

Note 4 : Low-Level input voltage of BYP terminal (3pin) (bypass MODE)

Note 5 : Input current of BYP terminal (3pin) (Vbyp=5V)

Note 6 : Input current of BYP terminal (3pin) (Vbyp=0v)

Note 7 : The mute signal which switches off the power supply of a power amplifier that is connected with MM1434 appears in the 10 terminal.

When the power supply of MM1434 is switched off, the pop noise occur.

We recommend muting the pop noise. The way is that the power supply of MM1434 is switched off after the power supply of the follow power amplifier is switched off.

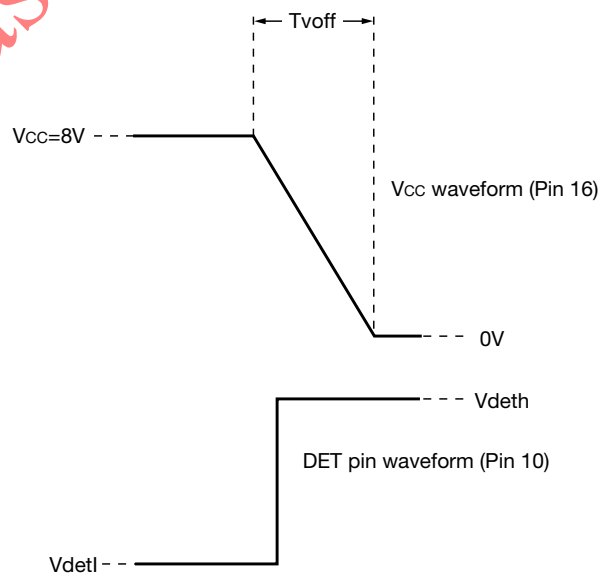

Note 8 : We recommend using the regulator for the power supply which occurs the ripple.

Note 9 : When the signal is input in SG1, it is the ratio of 7pin output voltage to 9pin output voltage.

Note 10 : When the signal is input in SG2, it is the ratio of 9pin output voltage to 7pin output voltage.

Measuring Circuit

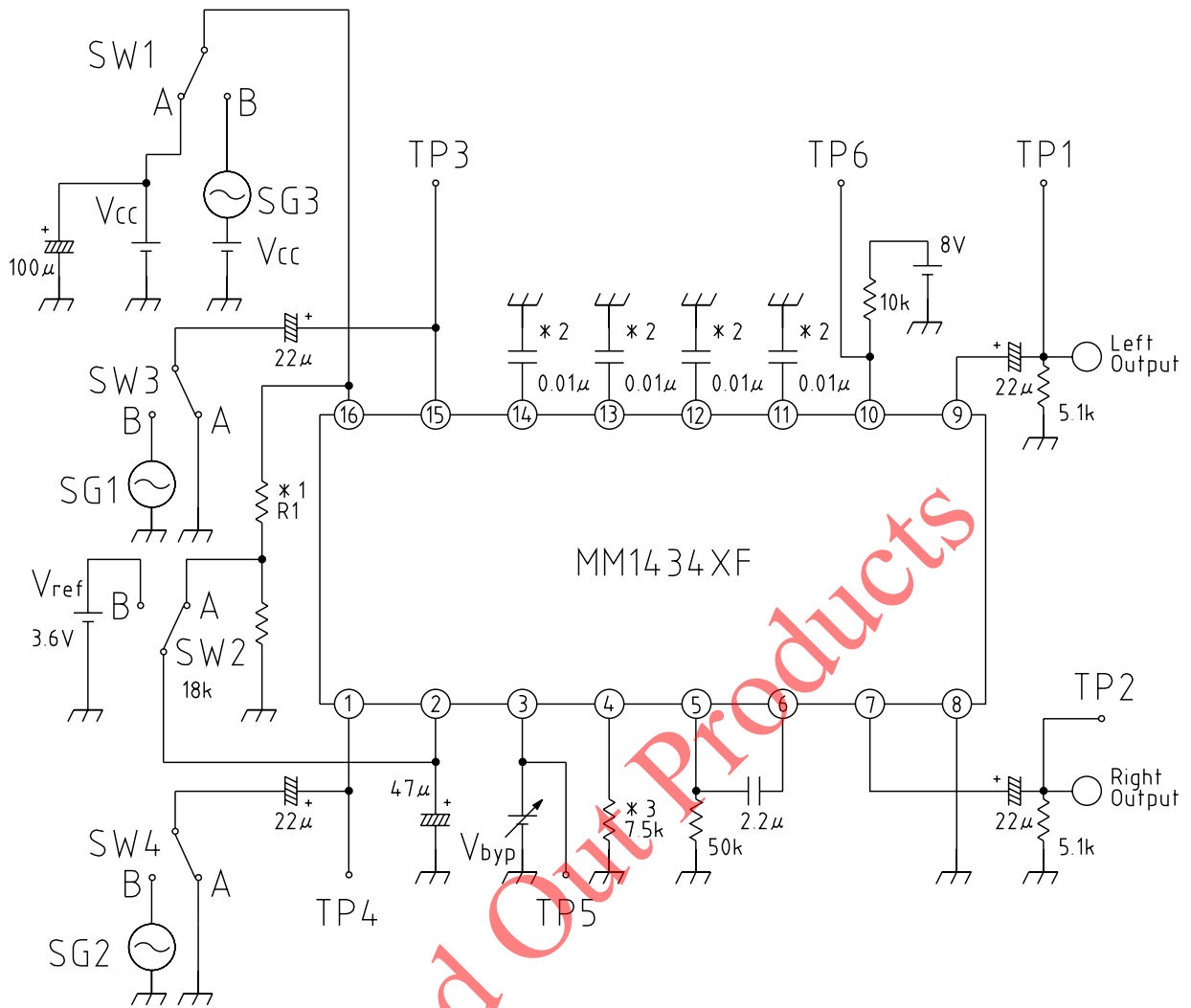

Note 1 : At $V_{CC} = 3.8V$ or $3V$, $R1 = 18k\Omega$

At $V_{CC} = 8V$, $R1 = 22k\Omega$

Note 2 : Capacitor Tolerance $\pm 5\%$

Note 3 : Resistor Tolerance $\pm 1\%$

Characteristics

■ (1) LIN-ROUT (RIN-LOUT) Frequency (Q Xpander)

LIN-ROUT (RIN-LOUT) Voltage gain-Frequency (Q Xpander)

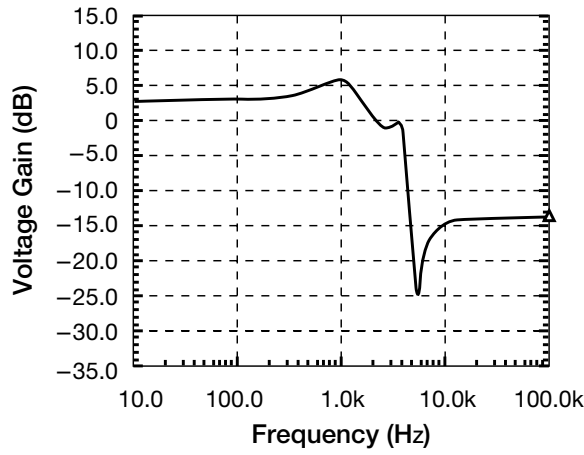

■ (2) LIN-LOUT (RIN-ROUT) Frequency (Q Xpander)

LIN-LOUT (RIN-ROUT) Voltage gain-Frequency (Q Xpander)

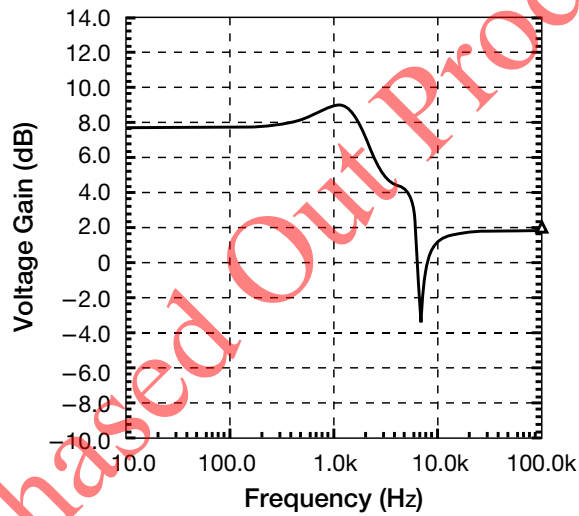

■ (3) Input voltage amplitude-Power supply voltage (Q Xpander)

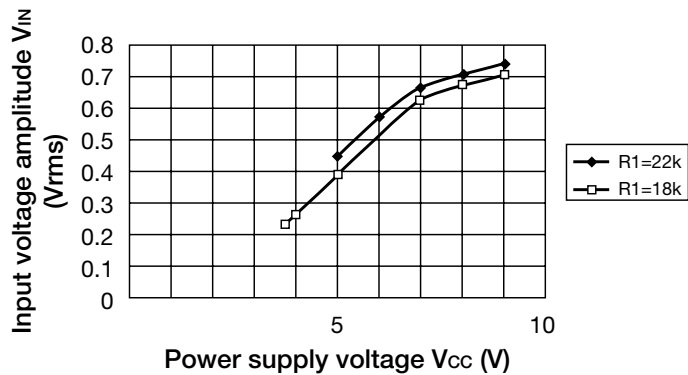

Note : It is input voltage that THD of output voltage is 1%. (f=1kHz)