

3ch HD-capable Video Amplifier IC Monolithic IC MM1794

April 28, 2009

Outline

This IC is a wide bandwidth 75Ω driver IC compatible with D3(1080i) that was developed for small mobile devices.

Since it is compatible with dual power supplies, an output coupling capacitor is not required, which contributes to minimizing the space for the set.

Furthermore, ultra low current consumption is achieved in consideration to the battery driving time of mobile devices.

Features

1. Ultra low current consumption : 30mA
2. Ultra-small package : SQFN-16
Body size : 3.0×3.0mm, non-lead type
3. Dual power supply specifications($V_{CC}=+3.0V$, $V_{EE}=-6.0V$) make output coupling capacitor unnecessary

Package

SQFN-16

Applications

1. Digital still cameras
2. DVD/Blu-ray disk drives
3. Set top boxes

Block Diagram

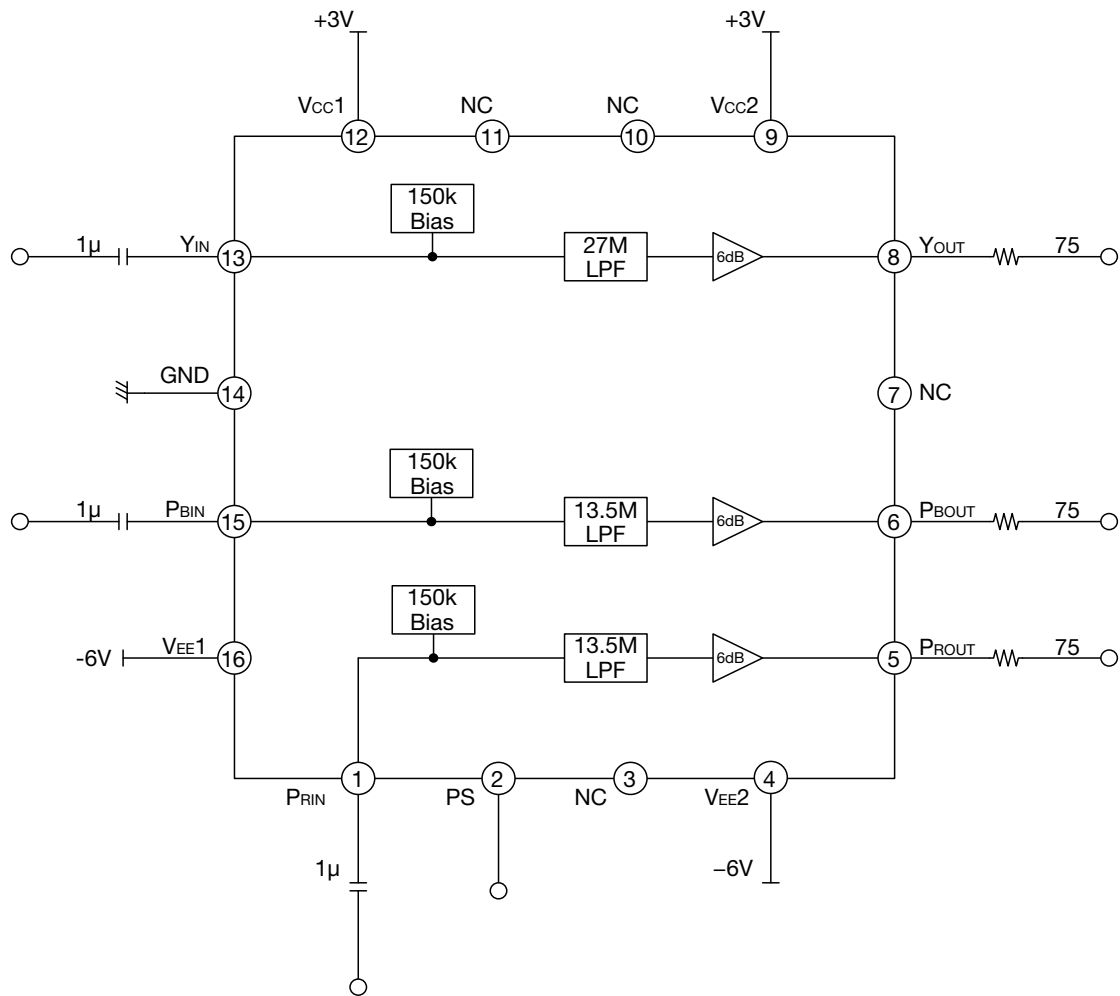

- Note : V_{CC2} (9pin) and V_{EE2} (4pin) are the power supplies for the output circuits inside IC.
- V_{CC1} (12pin) and V_{EE1} (16pin) are the power supplies for the other circuits inside IC.
- Note : V_{CC1} and V_{CC2} are open inside IC. Be sure to use it, connecting by external wiring.
- Note : V_{EE1} and V_{EE2} short-circuit by the substrate inside IC. The resistance of a substrate is not low. Be sure to use it, connecting by external wiring.

Pin Assignment

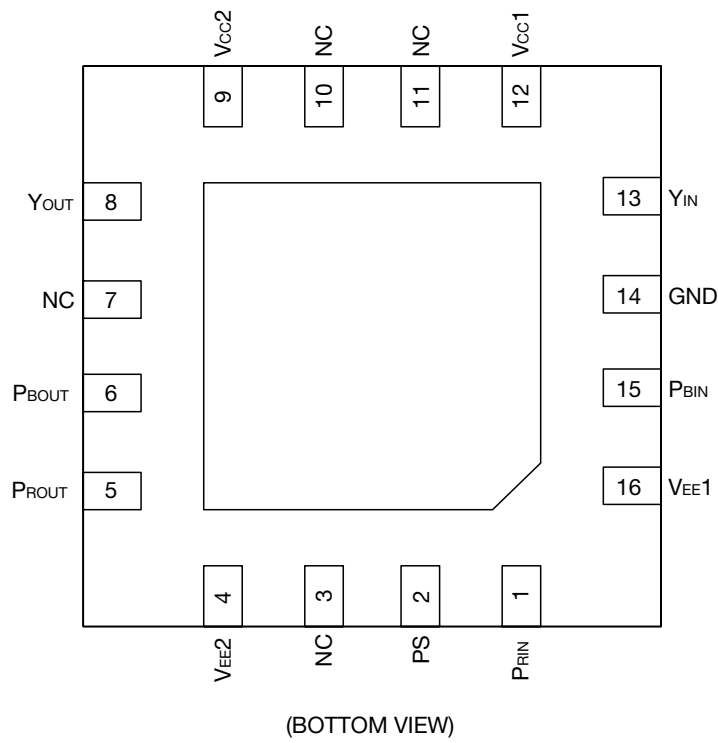
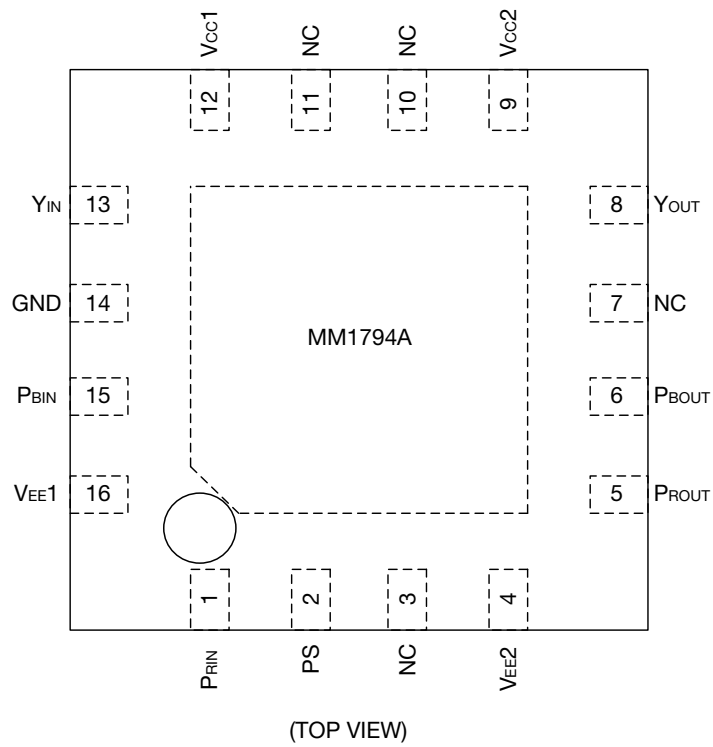

1	PRIN	6	PBOUT	11	NC	16	VEE1
2	PS	7	NC	12	VCC1		
3	NC	8	YOUT	13	YIN		
4	VEE2	9	VCC2	14	GND		
5	PROUT	10	NC	15	PBIN		

Pin Description

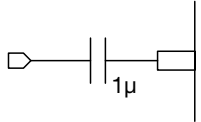
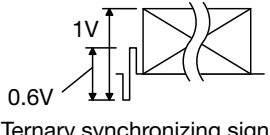
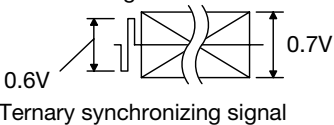
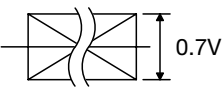
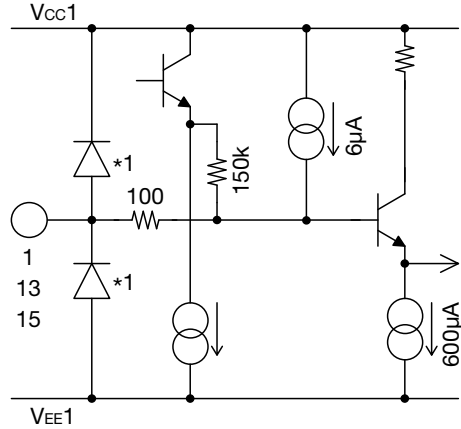

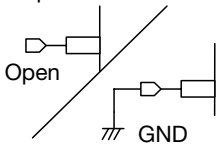
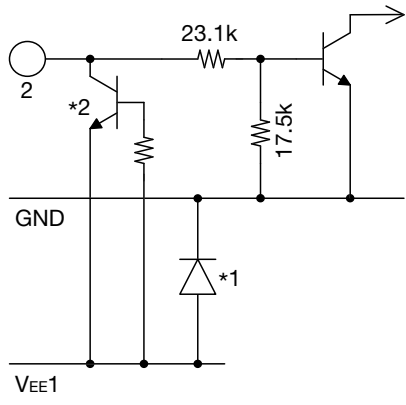
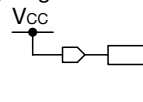
Pin No.	Pin name	Pin description	
1 13 15	P _{RIN} Y _{IN} P _{BIN}	Function	
		Component Y, Color difference P _B , P _R Signal Input or RGB Signal Input Pin to input component Y, Color difference P _B , P _R signals or RGB signals. Pin Voltage : 0V typ. Input Impedance : 150kΩ	
		External circuit	Equivalent circuit diagram
		 <p>When not using it : Open</p>	
		Input signal	
Component Y signal  <p>Ternary synchronizing signal</p>			
Color difference signal  <p>Ternary synchronizing signal</p>			
RGB signal 			
		 <p style="text-align: center;">*1 : Diode for ESD Protection</p>	

Pin No.	Pin name	Pin description					
2	PS	Function					
		Power Save select Select Power Save ON/OFF with a voltage applied to this pin. Threshold Voltage : $V_{PS} < 1V \rightarrow PS\ ON, 2V < V_{PS} \rightarrow PS\ OFF\ (Active)$ Input Impedance : $40.5k\Omega\ typ.$					
		External circuit	Equivalent circuit diagram				
		<div style="display: flex; justify-content: space-between;"> <div style="width: 45%;"> <p>PS ON : Open or Low</p>  </div> <div style="width: 45%;">  </div> </div>					
		<p>PS OFF(Active) : High</p>  <p>When not using it : V_{CC}</p>					
Input signal							
DC voltage : <table border="1" style="margin-left: auto; margin-right: auto;"> <tbody> <tr> <td></td> <td>Power Save</td> </tr> <tr> <td>0 to 1V or Open</td> <td>PS ON</td> </tr> <tr> <td>2V to V_{CC}</td> <td>PS OFF (Active)</td> </tr> </tbody> </table>			Power Save	0 to 1V or Open	PS ON	2V to V_{CC}	PS OFF (Active)
	Power Save						
0 to 1V or Open	PS ON						
2V to V_{CC}	PS OFF (Active)						

*1 : Diode for ESD Protection

*2 : Transistor for ESD Protection

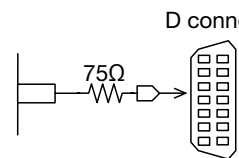
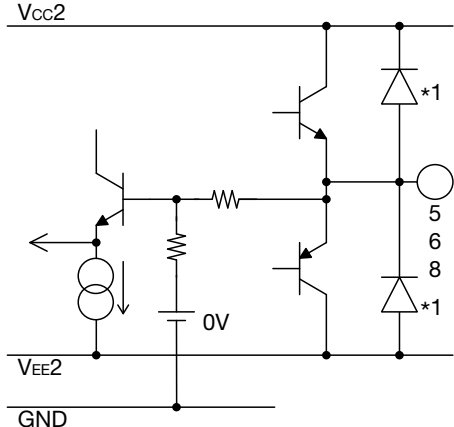
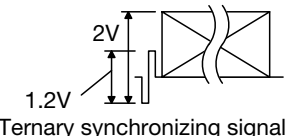
Pin No.	Pin name	Pin description
4 16	V _{EE2} V _{EE1}	Function
		<p>Negative Voltage Supply</p> <p>Pin to apply a negative supply voltage. Apply -6V. 4pin and 16pin are not shorted inside the IC. V_{EE2} is connected to an output stage circuit, and V_{EE1} is connected to a circuit other than an output stage circuit.</p> <p>Note : Please arrange power supply bypass capacitor near the terminal.</p>
		External circuit
		Input signal
		DC voltage : -7.5~-5.5V
		Equivalent circuit diagram
9 12	V _{CC2} V _{CC1}	Function
		<p>Positive Voltage Supply</p> <p>Pin to apply a positive supply voltage. Apply 3V. 9pin and 12pin are not shorted inside the IC. V_{CC2} is connected to an output stage circuit, and V_{CC1} is connected to a circuit other than an output stage circuit.</p> <p>Note : Please arrange power supply bypass capacitor near the terminal.</p>
		External circuit
		Input signal
		DC voltage : 2.7~5.3V
		Equivalent circuit diagram

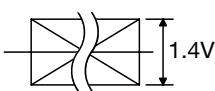
Pin No.	Pin name	Pin description	
Function			
<p>Component Y , Color difference P_B, P_R Signal Output or RGB Signal Output Pin to output component Y , Color difference P_B, P_R signals or RGB signals.</p> <p>Pin Voltage : 0V typ. Output Dynamic Range : 3.0Vp-p typ.</p>			
External circuit		Equivalent circuit diagram	
5 6 8	P _{ROUT} P _{BOUT} Y _{OUT}	<p style="text-align: center;">D connector</p>  <p style="text-align: center;">When not using it : Open</p>	 <p style="text-align: center;">*1 : Diode for ESD Protection</p>
		Output signal	
		<p>Component Y signal</p>  <p style="text-align: center;">Ternary synchronizing signal</p>	
		<p>Color difference signal</p>  <p style="text-align: center;">Ternary synchronizing signal</p>	
<p>RGB signal</p> 			

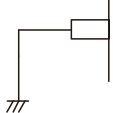
Pin No.	Pin name	Pin description	
14	GND	Function	
		Ground Ground pin.	
		External circuit	Equivalent circuit diagram
			—
		Input signal	—
—			

Absolute Maximum Ratings (Except where noted otherwise, Ta=25°C)

Item	Symbol	Ratings	Units
Storage temperature	T _{STG}	-55~+150	°C
Operating temperature	T _{OPR}	-40~+85	°C
Positive supply voltage	V _{CC} max.	+5.5	V
Negative supply voltage	V _{EE} max.	-7.5	V
Power dissipation	P _{D1} (Note1)	1.0	W
	P _{D2} (Note2)	1.1	W

Note1 : Board mounting power dissipation. Board size 110×41×0.8mm
 Layer : 4 Layers Material : Glass epoxy Wire rate : 65% TAB solder : nothing(0%)
 Note2 : Board mounting power dissipation. Board size 110×41×0.8mm
 Layer : 4 Layers Material : Glass epoxy Wire rate : 65% TAB solder : 100%

Recommended Operating Conditions

Item	Symbol	Ratings	Units
Operating temperature	T _{OPR}	-40~+85	°C
Positive operating voltage	V _{CCOP}	2.7~5.3	V
Negative operating voltage	V _{EEOP}	-7.5~-5.5	V

Electrical Characteristics (DC Character) (Except where noted otherwise, Ta=25°C, VCC=3V, VEE=-6V)

Item		Symbol	Measurement conditions	Min.	Typ.	Max.	Units
Positive Supply current		ICC	No signal VPS=3V	21	30	39	mA
Negative Supply current		IEE	No signal VPS=3V	21	30	39	mA
Positive Supply current on Power Save		ICC_PS	No signal PS open or VPS=0V		0.1	1	μA
Negative Supply current on Power Save		IEE_PS	No signal PS open or VPS=0V		0.1	1	μA
Terminal voltage	Input	VIN	13, 15, 1pin		0.0		V
	Output	VOUT	8, 6, 5pin	-0.18	0.0	0.18	V
	Output 75Ω termination	VOUT75	75Ω termination point	-0.09	0.0	0.09	V
PS Control terminal input voltage	High	VPSH	2 pin	2.0		VCC	V
	Low	VPSL	2 pin	GND		1.0	V
PS terminal input current		IPSH	2 pin VPS=3V	50	85	120	μA
PS terminal leak current		IPSL	2 pin VPS=0 V		30	100	nA
Negative Power Supply permission reverse voltage (Note4)		VEEreverse1	No signal at Power Save			0.36	V
		VEEreverse2	Ta=85°C No signal at Power Save			(0.16) (Note3)	V

Note3 : The inside of a parenthesis is a design guarantee value.

Note4 : About Negative Power Supply permission reverse voltage.

It is the specification applied at the time of the power save ON (PS terminal 0 - 1V or Open).

If the potential between GND-VEE is reversed (VEE>GND) and permission voltage is exceeded when VEE is OFF and VCC is ON, parasitism diode will turn on and current will flow between VCC-GND.

When VEE is OFF and VCC is ON, please hold down the voltage between VEE-GND to below "Negative Power Supply permission reverse voltage".

Power Save ON (PS<1V or Open)		Positive Power Supply VCC	
		ON (Example : +3V)	OFF (Open)
Negative Power Supply VEE	ON (Example : -6V)	don't care	don't care
	OFF (Open)	VEE-GND<Negative Power Supply permission reverse voltage	don't care

Note : When a device is the power save OFF(active), VEE=OFF and VCC=ON are prohibition conditions.

Power Save ON =Device Active (PS>2V)		Positive Power Supply VCC	
		ON (Example : +3V)	OFF (Open)
Negative Power Supply VEE	ON (Example : -6V)	don't care	don't care
	OFF (Open)	Prohibition	don't care

Electrical Characteristics (AC Character) (Except where noted otherwise, Ta=25°C, VCC=3V, VEE=-6V)

Item	Symbol	Measurement conditions	Min.	Typ.	Max.	Units
Input impedance	Y _{IN} , P _{BIN} , P _{RIN}	13, 15, 1pin	100	150	200	kΩ
Voltage gain	G _{Y, PB, PR}	SIN wave : 1V f=100kHz	5.7	6.0	6.3	dB
Frequency characteristic 1 (Y)	f _{1Y}	SIN wave : 1V 27MHz/100kHz	-3.0	-1.0		dB
	f _{2Y}	SIN wave : 1V 54MHz/100kHz		-26	-20	dB
Frequency characteristic 2 (P _B , P _R)	f _{3PB, PR}	SIN wave : 1V 13.5MHz/100kHz	-3.0	-1.0		dB
	f _{4PB, PR}	SIN wave : 1V 54MHz/100kHz		-30	-20	dB
Output dynamic range	DR _{YOUT} , P _{BOUT} , P _{ROUT}	SIN wave : 100kHz THD=1.0%	2.6	3.0		V
Group delay 1 (Y)	t _{1GDY}	at 100kHz		20	40	ns
Group delay 2 (P _B , P _R)	t _{2GDPB, PR}	at 100kHz		20	40	ns
Group delay deviation 3 (Y)	Δt _{3GDY}	to 4MHz		1	10	ns
		to 12MHz		1	10	ns
Group delay deviation 4 (P _B , P _R)	Δt _{4GDPB, PR}	to 4MHz		1	10	ns
		to 6MHz		1	10	ns
		to 12MHz		6	15	ns
Between channel Group delay deviation 5	Δt _{5chGD}	Between Y and P _B (P _R) at 4MHz		2	10	ns
Between channel Group delay deviation 6	Δt _{6chGD}	Between Y and P _B (P _R) at 12MHz		5	10	ns
Differential gain	DG (Y _{OUT})	Staircase signal 1V		1	2	%
Differential phase	DP (Y _{OUT})	Staircase signal 1V		1	2	deg
Crosstalk 1	CT1	f=4.43MHz, 1V		-60	-55	dB
Crosstalk 2	CT2	f=20MHz, 1V		-45	-40	dB
S/N	SN _{Y, PB, PR}	BW : 100k~12MHz		65		dB

Measuring Circuit

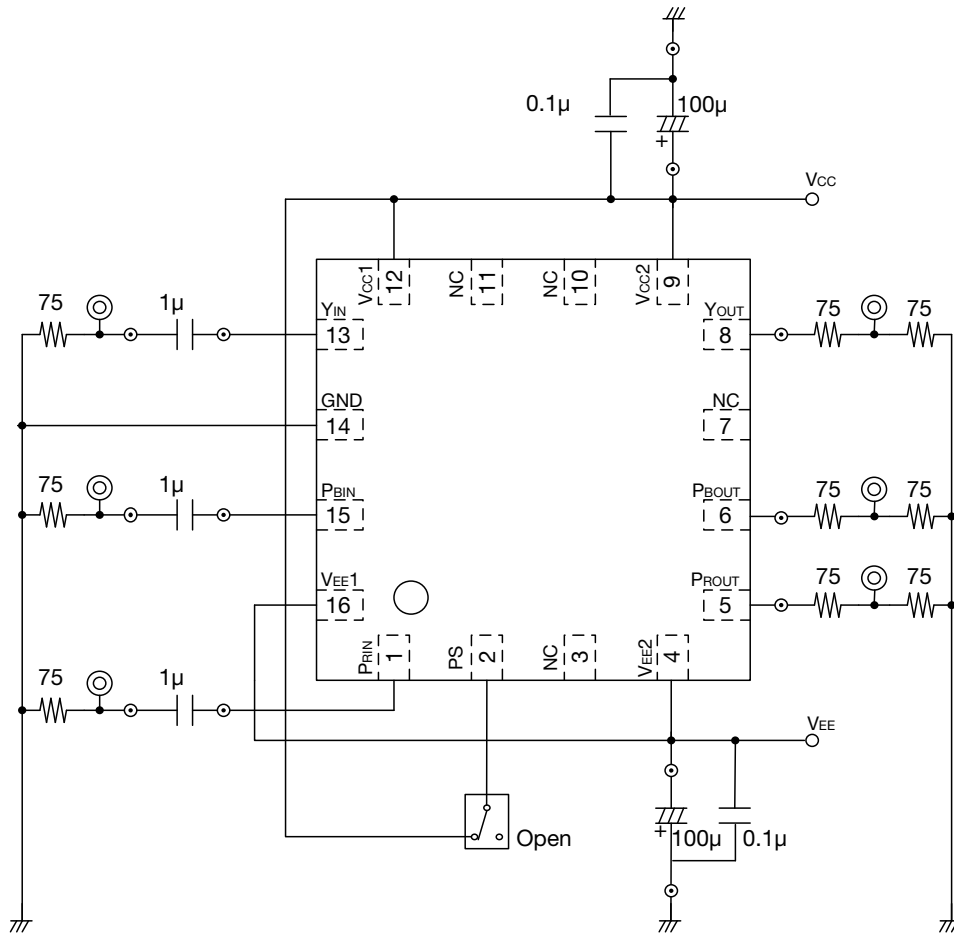

Switch Control Table

Power save select

Control terminal	Power save
PS	
Low (Open)	ON
High	OFF

Application Circuit

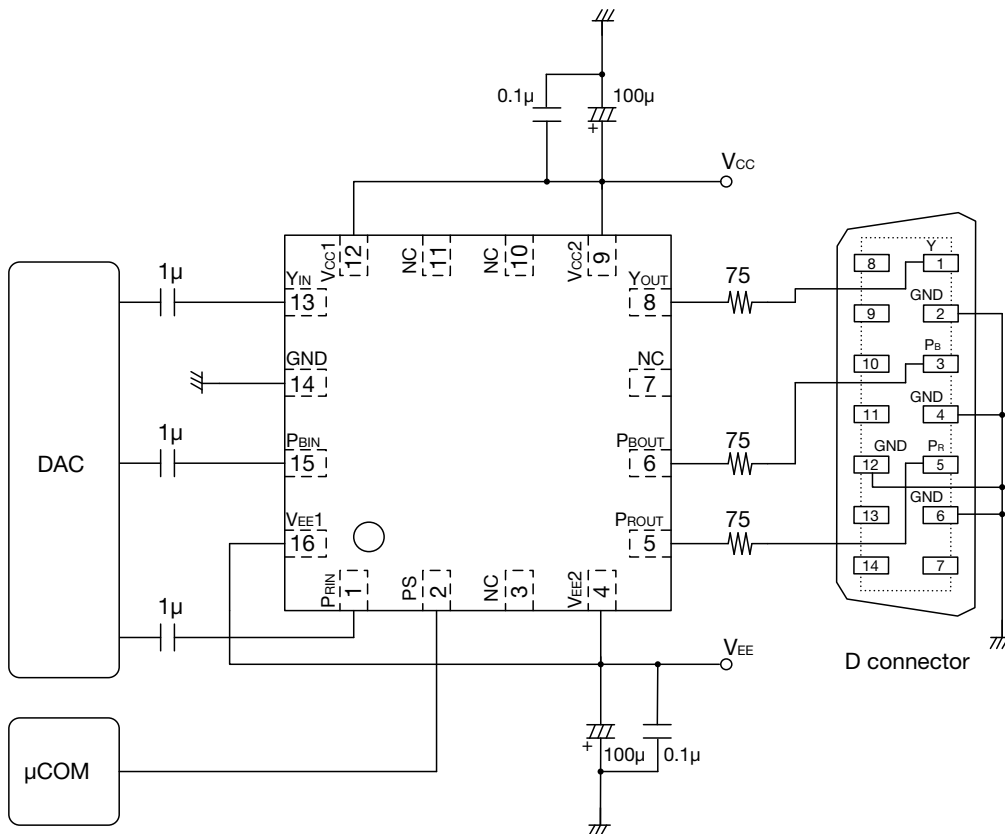

Note : Please arrange power supply bypass capacitor near the V_{CC} (V_{EE}) terminal (pin).
 Note : Please arrange the stray capacity component added to a signal output terminal to 20pF or less.

Typical Negative Power Supply Circuit

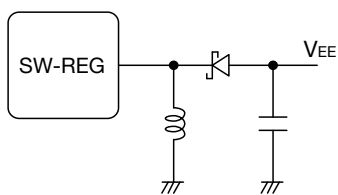

Note : In modes of operation, such as standby of the set to be used, When V_{CC} is turned on in the state of V_{EE}OFF for a long time, Please clamp a V_{EE} terminal with schottky barrier diode etc. and be not lifted 0.36V(T_a=25°C) or more from GND potential.
 For example, it is satisfactory also as negative power circuit composition which used switching regulator as shown in the above figure.

■ Power supply starting (bringing down) sequence recommendation

	Starting	It brings down
Recommendation	<p>The diagram shows three signals: PS, VCC, and VEE. PS and VCC are initially OFF. VEE is initially OFF. At a certain point, VEE turns ON to -6V. After a short delay, VEE turns OFF. Then, PS and VCC both turn ON to +3V.</p>	<p>The diagram shows three signals: PS, VCC, and VEE. PS and VCC are initially ON to +3V. VEE is initially OFF. At a certain point, PS and VCC both turn OFF. After a short delay, VEE turns ON to -6V.</p>
Conditional permission	<p>The diagram is similar to the 'Starting' sequence, but includes a shaded area between VEE turning ON and VEE turning OFF, during which VCC is OFF. This shaded area represents a conditional permission period.</p>	<p>The diagram is similar to the 'It brings down' sequence, but includes a shaded area between VEE turning ON and VEE turning OFF, during which VCC is OFF. This shaded area represents a conditional permission period.</p>

Conditional permission
 (A permission is granted only when V_{EE} potential is clamped to $0.36V(T_a=25^\circ C)$ or less for external diode.)

Note : If V_{CC} turns on in the state where substrate potential is unfixed, parasitic diode will turn on and an overcurrent (about 70mA) will flow between V_{CC} -GND.

Note : When you use the sequence which turns on V_{CC} at the time of V_{EE} OFF, Please insert the sufficiently low element of V_f like schottky barrier diode between V_{EE} -GND, and press down V_{EE} potential to $0.36V(T_a=25^\circ C)$ or less.

■ Power supply starting (bringing down) sequence prohibition mode

Let power supply operation in case PS terminal is High be prohibition mode.

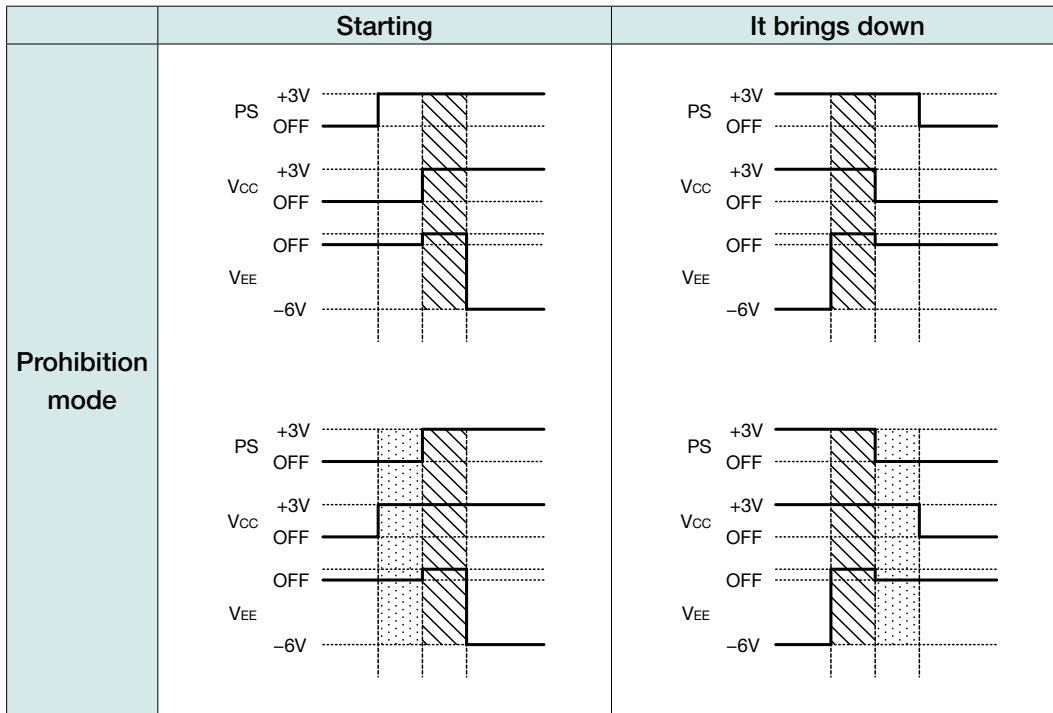

/// Prohibition mode

Note : Since the current between V_{CC} - V_{EE} increases when PS terminal is High (Active), it becomes impossible for a diode clamping circuit to be unable to prevent an overcurrent, either.

Please be sure to set PS terminal to Low (Open) in the case of power supply operation in which the potential of V_{EE} becomes unfixed.

Characteristics

■ Frequency Characteristic 1 (Y_{OUT})

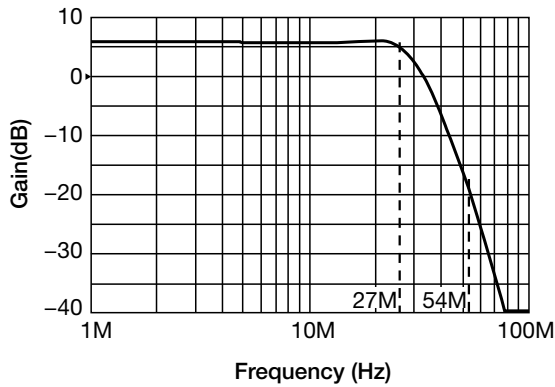

■ Group delay 1 (Y_{OUT})

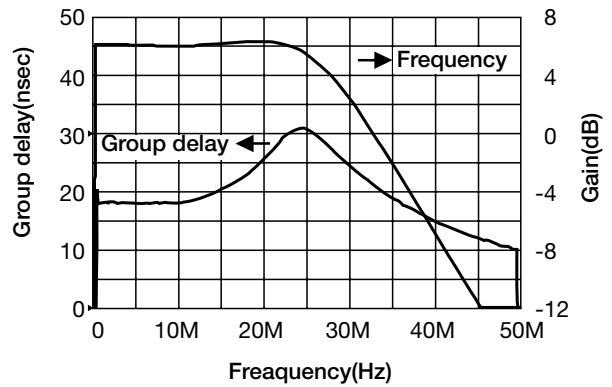

■ Frequency Characteristic 2 (P_{BOU}T)

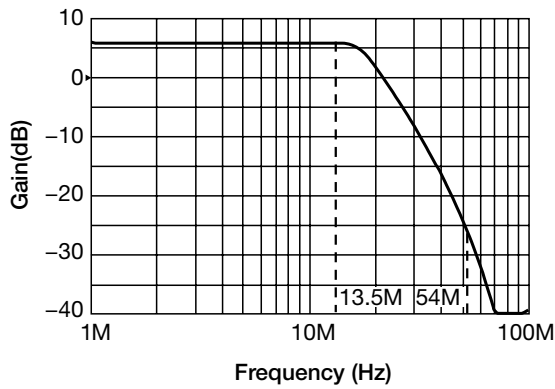

■ Group delay 2 (P_{BOU}T)

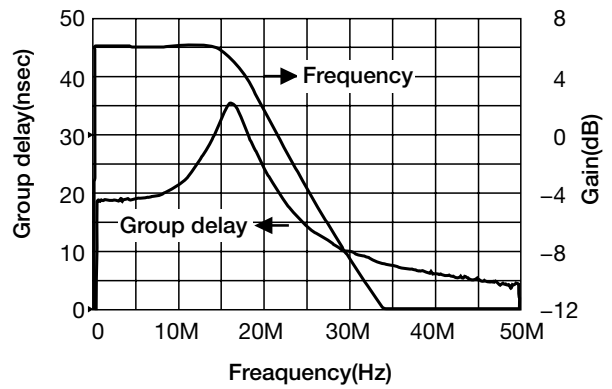

■ Frequency Characteristic 3 (P_{ROU}T)

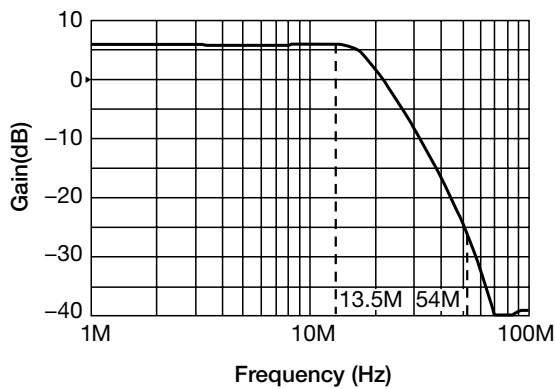

■ Group delay 3 (P_{ROU}T)

