

# Video Switch for DVD Recorders

## Monolithic IC MM1697BJ

### Outline

This IC is a video switch IC that includes an LPF (anti-aliasing filter) required before A/D conversion for DVD recorders, etc. It provides three input channels for composite video (CV), three input channels for S-Video (Y, C), one output channel for Y/CV<sub>OUT</sub> (used for both Y and CV), one output channel for C<sub>OUT</sub>, and one output channel for CV<sub>OUT</sub> (select V<sub>IN</sub> or Y<sub>IN</sub>+C<sub>IN</sub>). It also includes S-terminal connection detection function, which is ideal as a video input switch for DVD recorders that perform A/D conversion.

### Features

1. Input channel: Composite video input ... 3 channels  
S-Video (Y, C) ... 3 channels
2. Includes a high performance LPF (anti-aliasing filter)
  - 3dB pass bandwidth: 7MHz (typ.)
  - Attenuation at 10.7MHz: –36dB (typ.)
  - Attenuation at 13.5MHz: –40dB (typ.)
  - Attenuation at 27.0MHz: –37dB (typ.)
3. Includes a Y+C amplifier (Y/C MIX)
4. Includes 2 channels for detecting S-terminal connection

### Package

SSOP-24B

### Applications

DVD recorder

### Pin Assignment

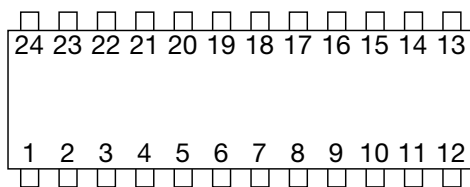

SSOP-24B  
(TOP VIEW)

1	VCC	9	GND	17	Y <sub>IN3</sub> /V <sub>IN4</sub>
2	C <sub>IN1</sub>	10	V <sub>IN2</sub>	18	GND
3	S det1	11	GND	19	Y/V <sub>OUT</sub>
4	C <sub>IN2</sub>	12	V <sub>IN3</sub>	20	V <sub>OUT</sub>
5	S det2	13	Y <sub>IN1</sub>	21	C <sub>OUT</sub>
6	C <sub>IN3</sub>	14	0dB/6dB	22	CTRL3
7	BIAS	15	Y <sub>IN2</sub>	23	CTRL2
8	V <sub>IN1</sub>	16	GND	24	CTRL1

Block Diagram

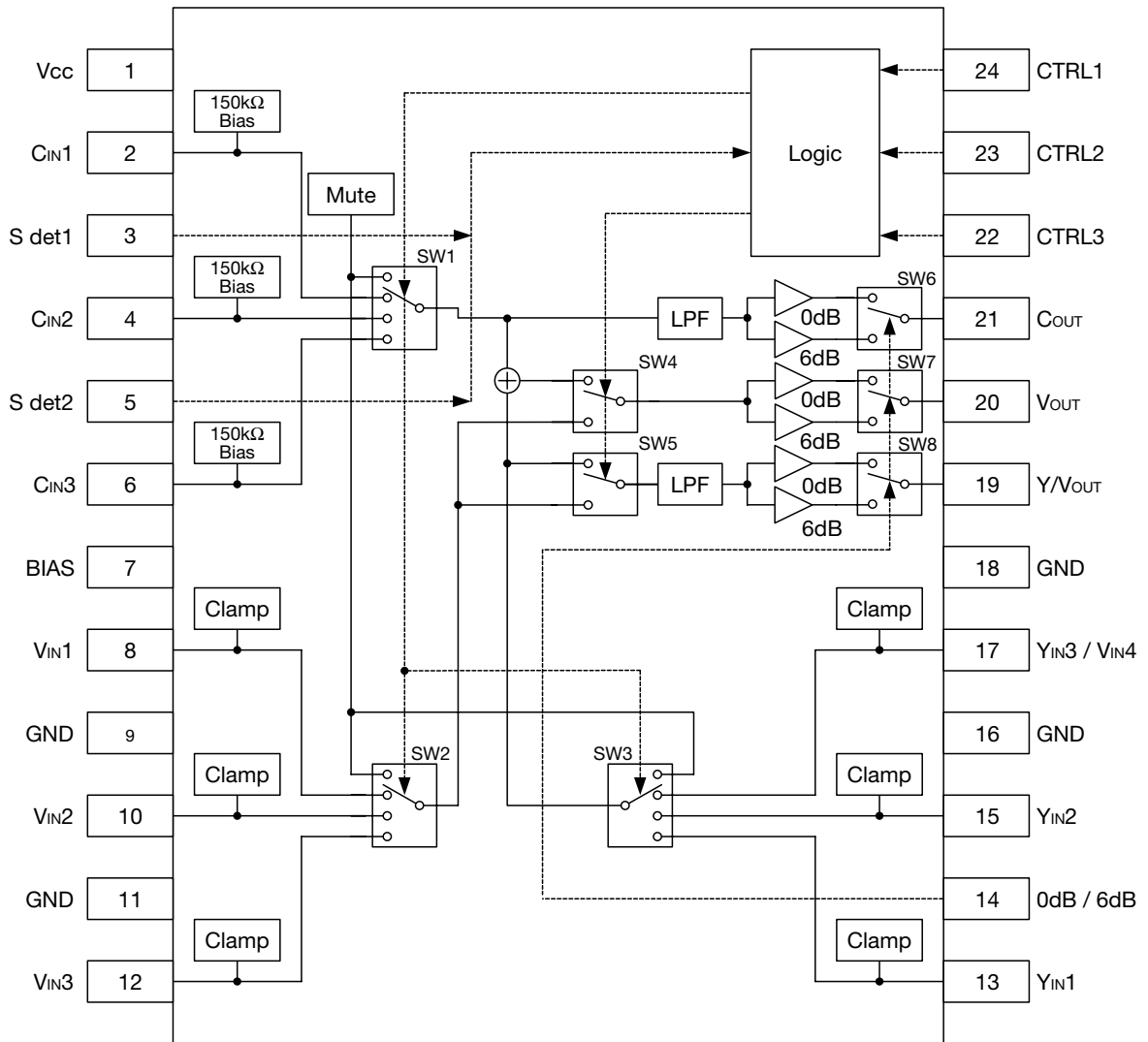

Pin Description

Pin no.	Pin name	Function	Internal equivalent circuit diagram
1	Vcc	Vcc	
2 4 6	CIN1 CIN2 CIN3	Chroma signal input 150kΩ bias input (Average clamp input)	

Pin no.	Pin name	Function	Internal equivalent circuit diagram
3 5	Sdet 1 Sdet 2	S-terminal detect	
7	BIAS	Bias	
8 10 12	V <sub>IN1</sub> V <sub>IN2</sub> V <sub>IN3</sub>	Video signal input (Composite video) Sync tip clamp input	
9 11 16 18	GND	Ground	

Pin no.	Pin name	Function	Internal equivalent circuit diagram
13 15 17	Y <sub>IN1</sub> Y <sub>IN2</sub> Y <sub>IN3</sub> /V <sub>IN4</sub>	Video signal input (Y) Sync tip clamp input	
14	0dB/6dB	0dB/6dB control select	
19 20 21	Y/V <sub>OUT</sub> V <sub>OUT</sub> C <sub>OUT</sub>	Signal output	
22 23 24	CTRL1 CTRL2 CTRL3	Control select	

**Absolute Maximum Ratings** (Ta=25°C)

Item	Symbol	Ratings	Units
Storage temperature	T <sub>STG</sub>	-65~+150	°C
Operating temperature	T <sub>OPR</sub>	-40~+85	°C
Supply voltage	V <sub>CC max.</sub>	7	V
Allowable loss	P <sub>d</sub>	650	mW

**Recommended Operating Conditions**

Item	Symbol	Ratings	Units
Operating temperature	T <sub>OPR</sub>	-40~+85	°C
Operating supply voltage	V <sub>CCOP</sub>	4.5~5.5	V

**Electrical Characteristics** (Except where noted otherwise, Ta=25°C, V<sub>CC</sub>=5V)

Item	Symbol	Measurement conditions	Min.	Typ.	Max.	Units	
Supply current 1	I <sub>CC1</sub>	No signal	33	48	63	mA	
Supply current 2	I <sub>CC2</sub>	No signal (at Power saving)	3	5	7	mA	
Terminal voltage	Chroma input	V <sub>CIN1-3</sub>	2, 4, 6 pin	1.6	2.1	2.6	V
	Composite video input	V <sub>VIN1-3</sub>	8, 10, 12pin	1.0	1.5	2.0	V
	Luminance input	V <sub>YIN 1, 2, YIN3/VIN4</sub>	13, 15, 17 pin	1.0	1.5	2.0	V
	Chroma output	V <sub>COUT</sub>	21 pin	1.6	2.1	2.6	V
	Composite video output	V <sub>VOUT</sub>	20 pin (14pin=H)	1.0	1.5	2.0	V
			20 pin (14pin=L)	0.4	0.7	1.0	V
Luminance output	V <sub>Y/VOUT</sub>	19 pin (14pin=H)	1.0	1.5	2.0	V	
		19 pin (14pin=L)	0.4	0.7	1.0	V	
CTRL terminal threshold voltage	V <sub>th1</sub>	22, 23, 24 pin	0.7	1.4	2.1	V	
0dB/6dB terminal threshold voltage	V <sub>th2</sub>	14 pin	0.7	1.4	2.1	V	
S detect of S det	V <sub>ths</sub>	3, 5 pin	0.7	1.4	2.1	V	
Input impedance	Z <sub>CIN 1-3</sub>	2, 4, 6 pin	100	150	200	kΩ	
Output force current	I <sub>OUT1</sub>	19, 20, 21 pin	4	5		mA	
Output sink current	I <sub>OUT2</sub>	19, 20, 21 pin	2.5	3		mA	
Voltage gain	G <sub>1COUT, VOUT, Y/VOUT</sub>	SIN wave: 1V f=100kHz	-0.5	0	0.5	dB	
	G <sub>2COUT, VOUT, Y/VOUT</sub>		5.7	6.0	6.3	dB	
Frequency characteristic	f <sub>1COUT, VOUT, Y/VOUT</sub>	SIN wave: 1V -3dB Bandwidth	6.0	6.6		MHz	
	f <sub>2COUT, Y/VOUT</sub>	SIN wave: 1V 10.74MHz/100kHz		-33	-30	dB	
	f <sub>3COUT, Y/VOUT</sub>	SIN wave: 1V 13.5MHz/100kHz		-40	-37	dB	
	f <sub>4COUT, Y/VOUT</sub>	SIN wave: 1V 27MHz/100kHz		-40	-35	dB	
Group delay	t <sub>GD (COUT, Y/VOUT)</sub>	at 100kHz		85	120	ns	

Item		Symbol	Measurement conditions	Min.	Typ.	Max.	Units
Group delay deviation		$\Delta t_{GD(COUT, Y/VOUT)}$	to 3.58MHz		15	30	ns
			to 4.43MHz		25	40	ns
Between channel group delay deviation		$\Delta t_{chGD}$	Between C and Y at 4.43MHz		2	20	ns
Differential gain		$DG_{VOUT, Y/VOUT}$	Staircase signal 1V		0.8	1.5	%
Differential phase		$DP_{VOUT, Y/VOUT}$	Staircase signal 1V		0.8	1.5	°
Input dynamic range		$DR_{CIN}$	Measure input terminal when sin wave: 100kHz THD=1.0% of output terminal (14pin=H)	1.4	2.5		V
		$DR_{VIN}$		1.4	2.5		V
		$DR_{Y/VIN}$		1.4	2.5		V
		$DR_{CIN}$	Measure input terminal when sin wave: 100kHz THD=1.0% of output terminal (14pin=L)	1.4	1.5		V
		$DR_{VIN}$		1.4	1.5		V
		$DR_{Y/VIN}$		1.4	1.5		V
Crosstalk	C <sub>OUT</sub>	$CT_{COUT}$	Crosstalk to the non-input root. $V_{IN}=1V, f=4.43MHz$		-60	-50	dB
	V <sub>OUT</sub>	$CT_{VOUT}$					
	Y/V <sub>OUT</sub>	$CT_{Y/VOUT}$					
S/N		$SN_{COUT, Y/VOUT}$	BW: 100k~6MHz		70		dB

Measuring Circuit

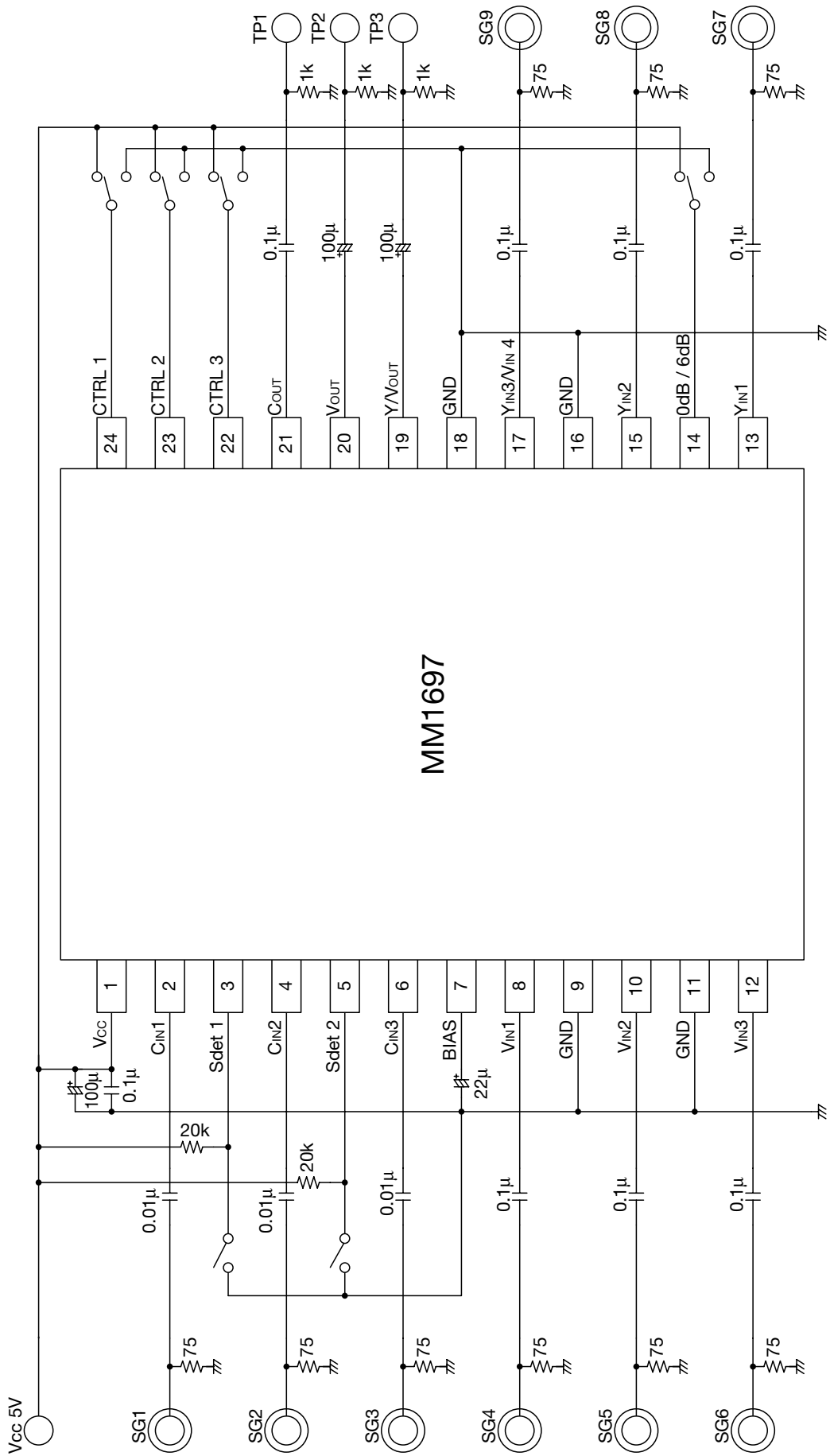

**Switch Control Table**

■ Input select

When not using a Sdet terminal

CTRL1	CTRL2	CTRL3	S det1	S det2	V <sub>OUT</sub>	Y/V <sub>OUT</sub>	C <sub>OUT</sub>
L	L	*	H	H	Mute	Mute	Mute
L	H	H			V <sub>IN1</sub>	V <sub>IN1</sub>	Mute
		L			C <sub>IN1</sub> +Y <sub>IN1</sub>	Y <sub>IN1</sub>	C <sub>IN1</sub>
H	L	H			V <sub>IN2</sub>	V <sub>IN2</sub>	Mute
		L			C <sub>IN2</sub> +Y <sub>IN2</sub>	Y <sub>IN2</sub>	C <sub>IN2</sub>
H	H	H			V <sub>IN3</sub>	V <sub>IN3</sub>	Mute
		L	C <sub>IN3</sub> +Y <sub>IN3</sub>	Y <sub>IN3</sub>	C <sub>IN3</sub>		

When using a Sdet terminal

CTRL1	CTRL2	CTRL3	S det1	S det2	V <sub>OUT</sub>	Y/V <sub>OUT</sub>	C <sub>OUT</sub>
L	L	*	*	*	Mute	Mute	Mute
L	H	H	H	*	V <sub>IN1</sub>	V <sub>IN1</sub>	Mute
		*	L	*	C <sub>IN1</sub> +Y <sub>IN1</sub>	Y <sub>IN1</sub>	C <sub>IN1</sub>
		L	*	*			
H	L	H	*	H	V <sub>IN2</sub>	V <sub>IN2</sub>	Mute
		*	*	L	C <sub>IN2</sub> +Y <sub>IN2</sub>	Y <sub>IN2</sub>	C <sub>IN2</sub>
		L	*	*			
H	H	H	*	*	V <sub>IN3</sub>	V <sub>IN3</sub>	Mute
		L	*	*	C <sub>IN3</sub> +Y <sub>IN3</sub>	Y <sub>IN3</sub>	C <sub>IN3</sub>

Note: When a Sdet terminal is not used, all mode can be controlled with only a CTRL terminal by making it Sdet1 and 2= H (V<sub>CC</sub>).

When a Sdet terminal is used, please attach the pull-up resistor of 20kΩ to Sdet1, Sdet2 terminal (3pin, 5pin).

\*: Don't care

■ Gain select

0dB/6dB	G <sub>COUT, VOUT, Y/VOUT</sub>
H	0dB
L	6dB

Application Circuit

■ S det terminal At the time of intact

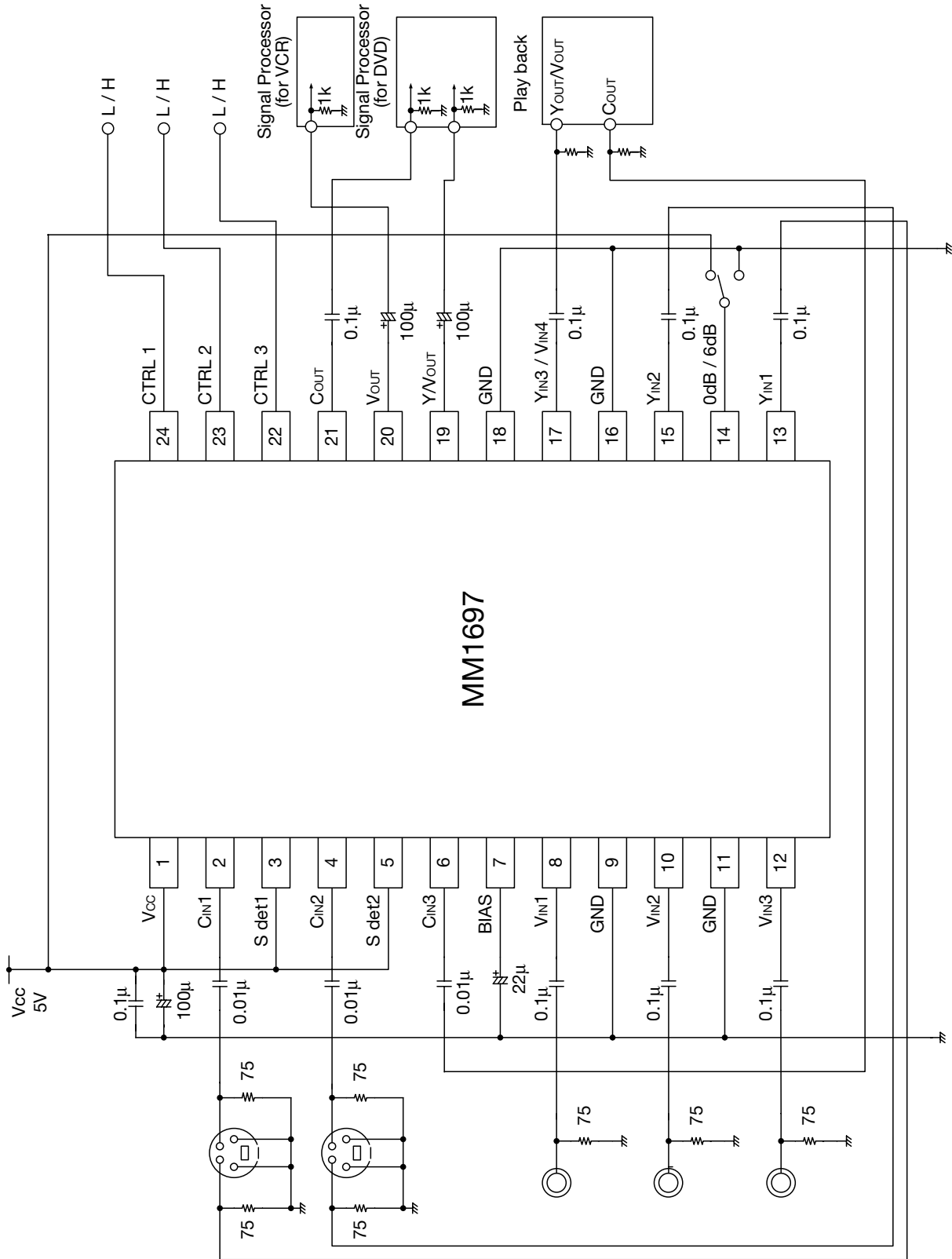

Note Please connect Sdet terminal to Vcc for the measure against a cross talk, when you do not use Sdet terminal. (3, 5pin)

- We shall not be liable for any trouble or damage caused by using this circuit.
- In the event a problem which may affect industrial property or any other rights of us or a third party happens during the use of information in these circuit, we shall not be liable for any problem, nor grant a license therefore.

■ S det terminal At the time of use

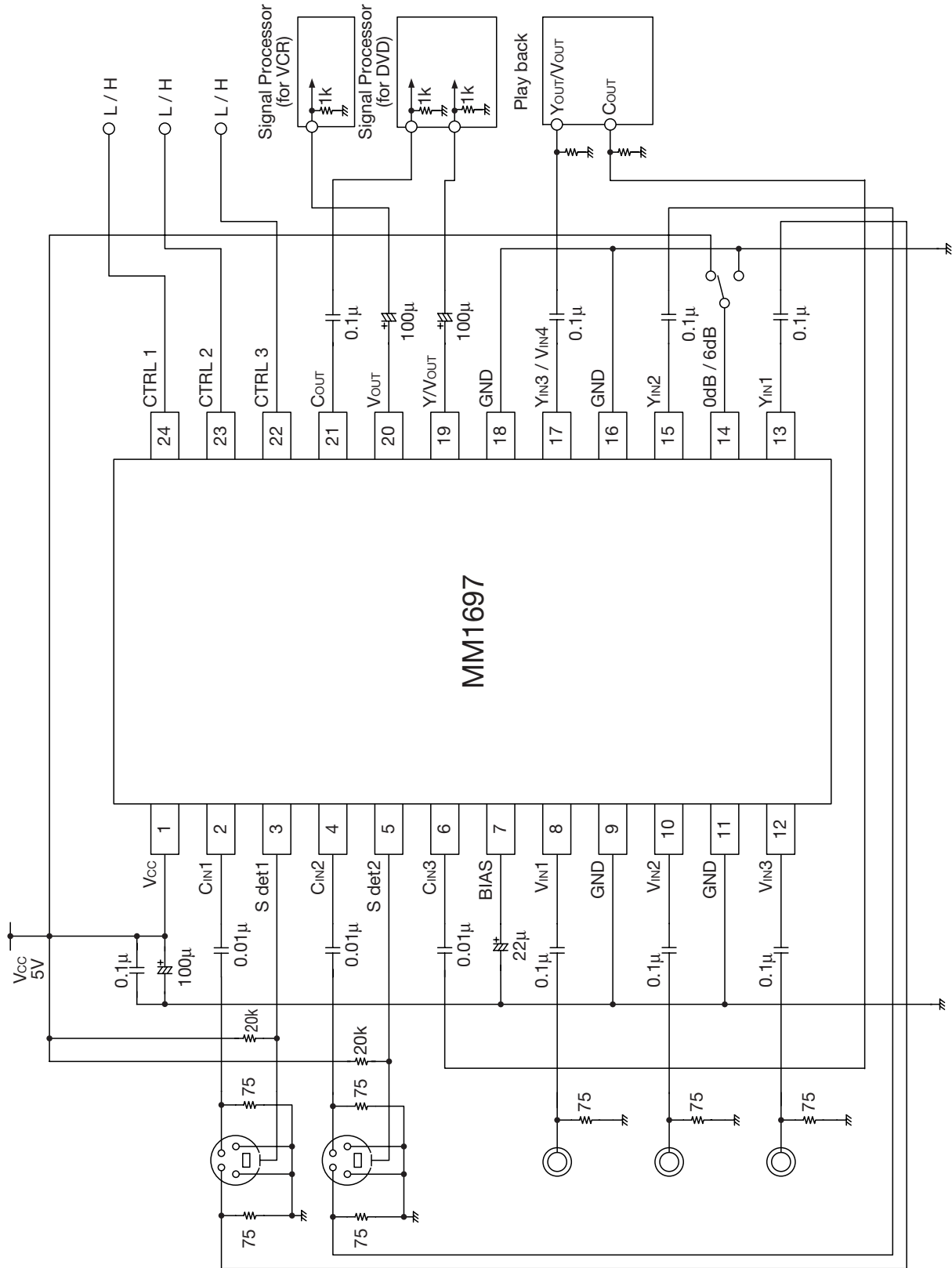

Note Please arrange power supply bypass capacitor near the Vcc terminal (1pin).  
Please attach the pull up resistor of 20kΩ to Sdet1, Sdet2 terminal (3pin, 5pin)

- We shall not be liable for any trouble or damage caused by using this circuit.
- In the event a problem which may affect industrial property or any other rights of us or a third party happens during the use of information in these circuit, we shall not be liable for any problem, nor grant a license therefore.