

H=1mm Slide Switches SSP Series

FEATURES

1. 1mm in height (horizontal).
2. Suitable for SMT reflow soldering.
3. Packaged in a tape (taping package) to allow the auto mounting of switches.
4. 1-pole, 2-contacts (SSP-122BHT), 1-pole, 3-contacts (SSP-132MHT).
5. Changeover timing cannot be specified.

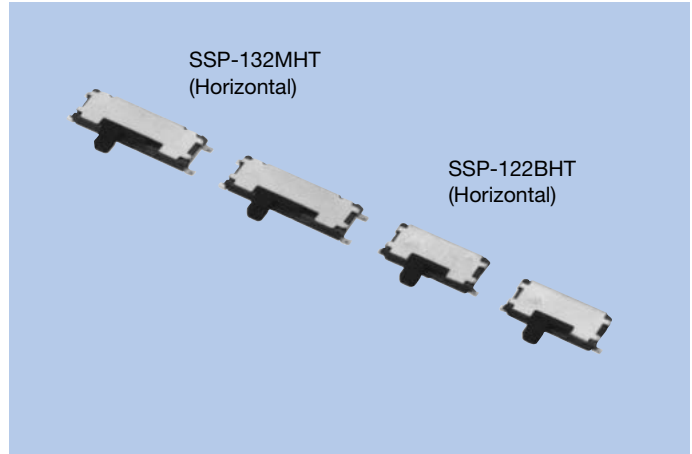

APPLICATIONS

1. For portable audios, radios, LCD TVs, video cameras, etc.
2. For protecting overwrite of memory cards.

MODEL NAME CODE

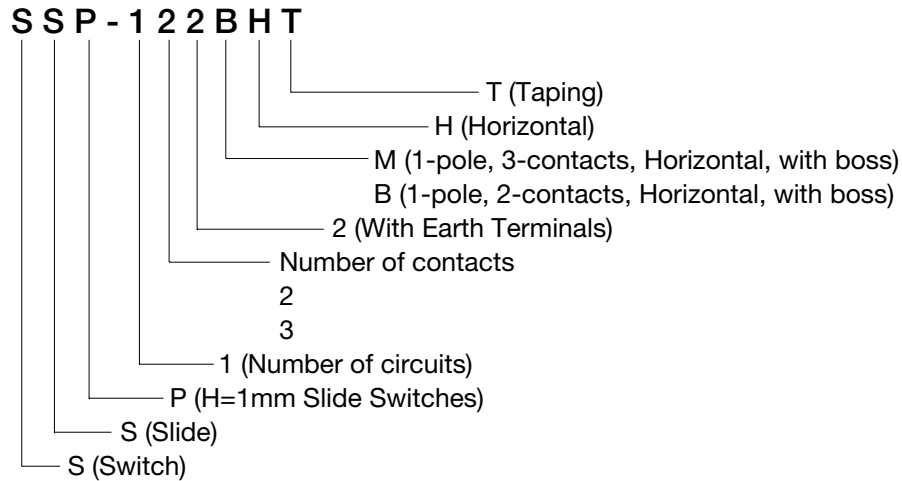

SPECIFICATIONS

Electrical Characteristics	Rating	0.3A, 4V DC
	Contact Resistance	1Ω or less
	Insulation Resistance	10MΩ or more
	Withstand Voltage	1 minute at 100V AC
Mechanical Characteristics	Operating Force	2-contacts type
		1.47±0.98N
		3-contacts type
Life		1.5±1N
		10,000cycles

TYPE

Model Name Code	Order Number	No. of Poles	No. of Contacts	Travel (mm)	Knob Direction	Boss	Pcs/Reel
SSP-122BHT	R66 6546	1	2	1.5	Horizontal	With	5,000
SSP-132MHT	R66 7050	1	3	1.5	Horizontal	With	5,000

DIMENSIONS

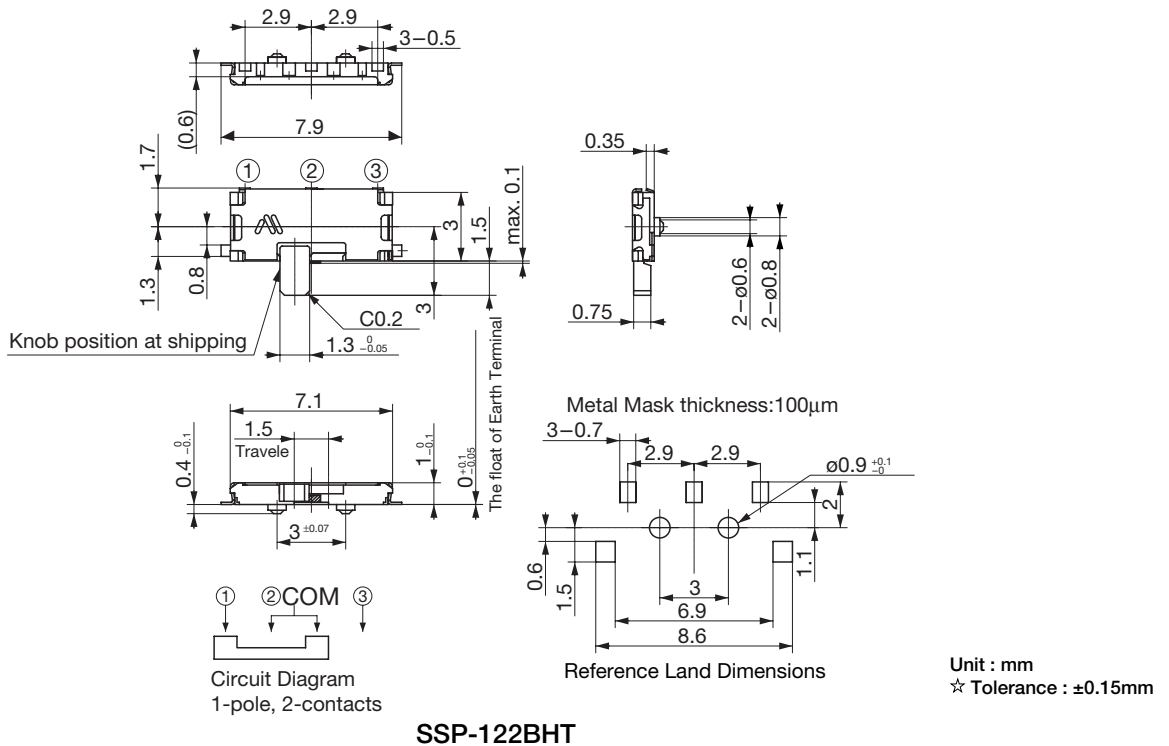

SSP-122BHT

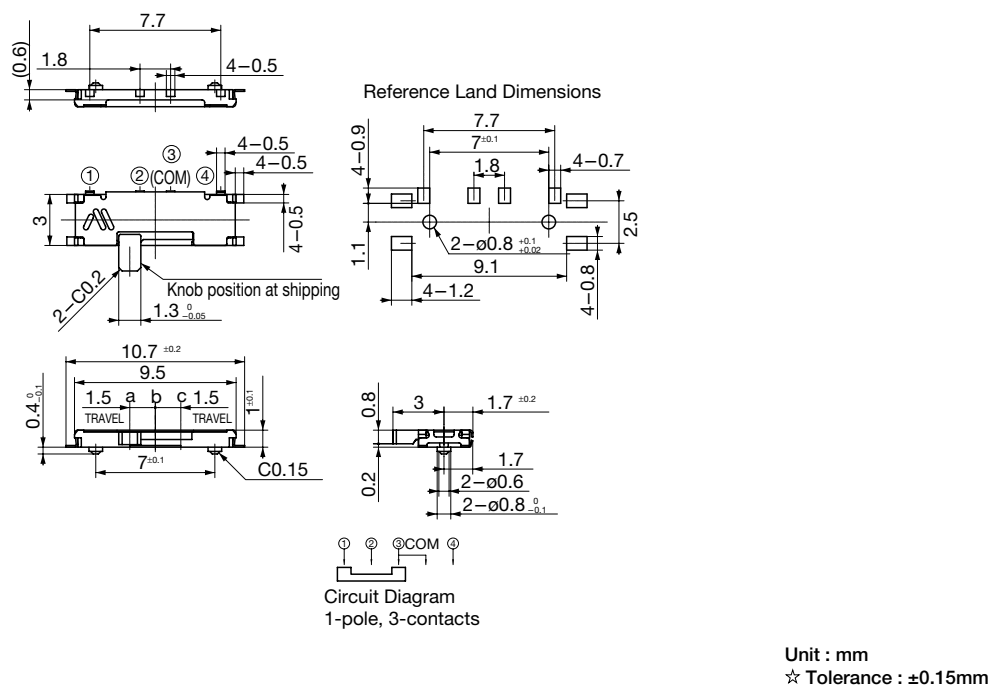

SSP-132MHT