

H=0.8mm Slide Switches SSN Series

FEATURES

1. 0.8mm in height.
2. Suitable for SMT reflow soldering.
3. Tape packaging supporting the auto mounting.
4. 1-pole, 2-contacts as standard.
5. Changeover timing cannot be specified.

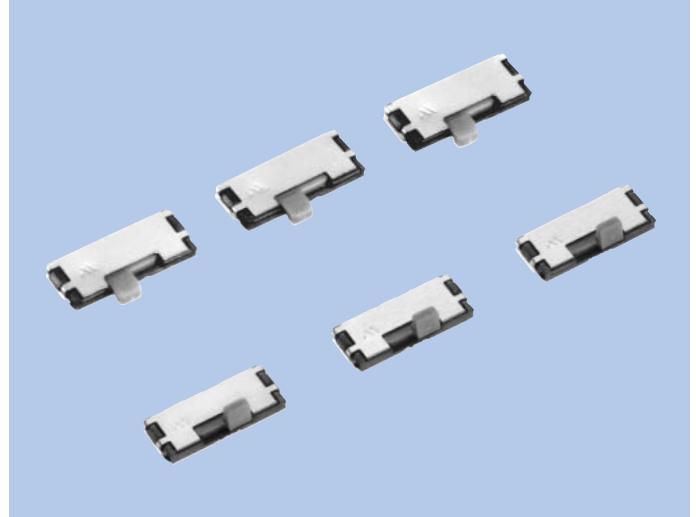

APPLICATIONS

1. For portable audios, remote controllers, DSCs, video players, mobile phones, PDAs, etc.
2. For power switches, hold switches, mode select switches.

MODEL NAME CODE

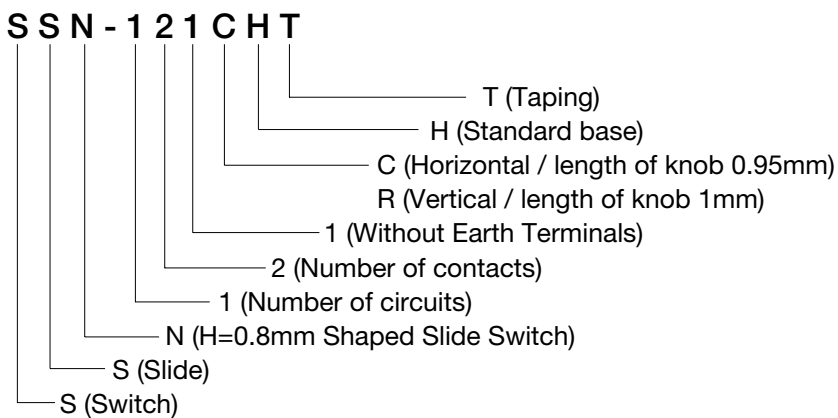

SPECIFICATIONS

Electrical Characteristics	Rating	0.3A, 4V DC
	Contact Resistance	1Ω or less
	Insulation Resistance	10MΩ or more
	Withstand Voltage	1 minute at 100V AC
Mechanical Characteristics	Operating Force	1.5 ^{+2.0} _{-1.0} N
	Life	10,000cycles

TYPE

Model Name Code	Order Number	No. of Poles	No. of Contacts	Travel (mm)	Knob Direction	Pcs/Reel
SSN-121CHT	R66 6753	1	2	1.5	Horizontal	5,000
SSN-121RHT	R66 7068	1	2	1.5	Vertical	3,000

DIMENSIONS

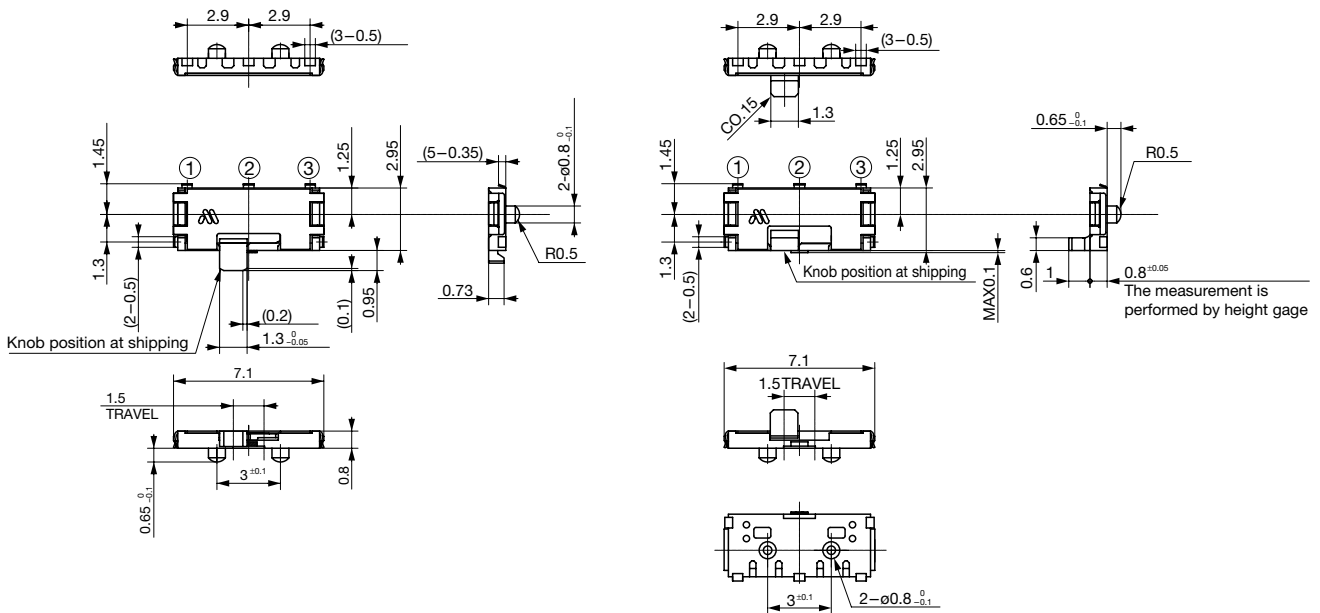

SSN-121CHT

SSN-121RHT

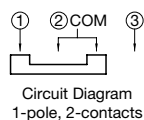
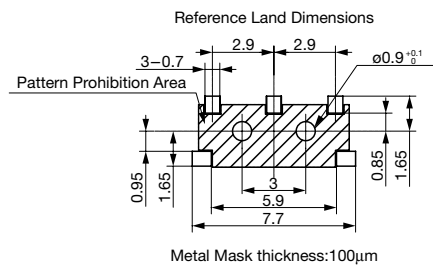

Unit : mm
 ☆ Tolerance : ±0.15mm