

# 150mA Dual Regulator Monolithic IC MM3148□N

## Outline

MM3148 is an IC developed as complex power supply for mobile devices. MM3148 consists of 2 circuits of positive power pressure regulator and a switching circuit for controlling each output.

Regulator output voltage can be set to be fixed in the range of 1.2-5.0V, depending on your requirement. Also, with the switching terminal for controlling each output, MM3148 is an IC most suitable for mobile devices.

## Features

- |                            |                                 |
|----------------------------|---------------------------------|
| 1. Dropout voltage         |                                 |
| 2. Ripple rejection        |                                 |
| 3. Output voltage accuracy | Vo1, Vo2 : ±2%                  |
| 4. No load input current   | Vo1 : 45µA typ. Vo2 : 45µA typ. |
| 5. Input voltage           | 6V max.                         |
| 6. Maximum output current  | 150mA max.                      |
| 7. Output ON/OFF control   | High : ON Low : OFF             |

## Package

SOT-26A

## Applications

1. Cellular phones
2. Portable music players
3. Digital still camera
4. Mobile game machines
5. PDA

**Block Diagram**

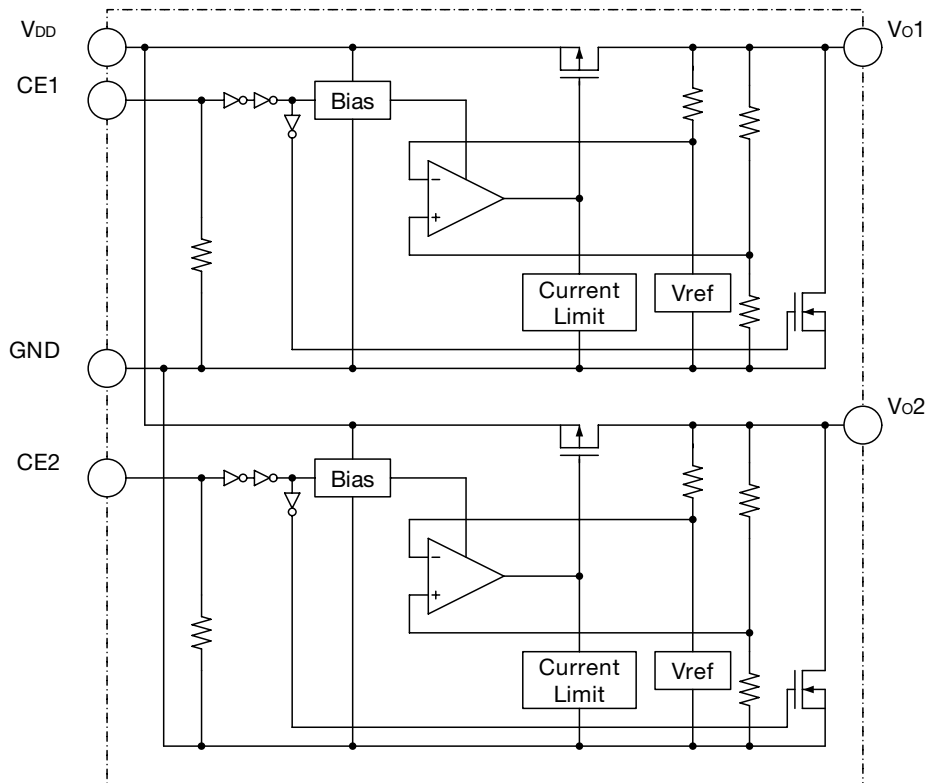

**Pin Assignment**

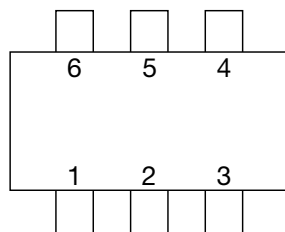

SOT-26A  
(TOP VIEW)

1	CE1
2	V <sub>DD</sub>
3	CE2
4	V <sub>o2</sub>
5	GND
6	V <sub>o1</sub>

**Pin Description**

Pin No.	Pin name	Function						
1, 3	CE1, CE2	ON/OFF-control 1, 2pin <table border="1" style="margin-left: 20px;"> <tr> <td>CE</td> <td>Output</td> </tr> <tr> <td>L</td> <td>OFF</td> </tr> <tr> <td>H</td> <td>ON</td> </tr> </table> Connect CE pin with V <sub>DD</sub> pin, when it is not used.	CE	Output	L	OFF	H	ON
CE	Output							
L	OFF							
H	ON							
2	V <sub>DD</sub>	Voltage-supply pin						
4, 6	V <sub>o2</sub> , V <sub>o1</sub>	Output 1, 2 pin						
5	GND	GND pin						

**Absolute Maximum Ratings** (Ta=25°C)

Item	Symbol	Ratings	Units
Storage temperature	T <sub>STG</sub>	-55~+125	°C
Supply voltage	V <sub>DD</sub>	7	V
CE1, 2 input voltage	V <sub>CE1, 2</sub>	-0.3~V <sub>DD</sub> +0.3	V
Output voltage 1, 2	V <sub>O1, 2</sub>	-0.3~V <sub>DD</sub> +0.3	V
Output current 1, 2	I <sub>O1, 2max.</sub>	200	mA
Allowable loss	P <sub>d</sub>	350 *note1	mW

\*note1 : with PC Board of glass epoxy. (25× 25 × 1.6tmm, Copper foil area 60%)

**Recommended Operating Conditions** (Ta=25°C)

Item	Symbol	Ratings	Units
Operating ambient temperature	T <sub>JOP</sub>	-40~85	°C
Operating voltage	V <sub>OP</sub>	2~6	V
Output current 1, 2	I <sub>O1, 2</sub>	0~150	mA

**Electrical Characteristics 1** (Except where noted otherwise Ta=25°C, V<sub>DD</sub>=V<sub>O</sub> (typ.)+1V, V<sub>CE</sub>=V<sub>DD</sub>)

Item	Symbol	Measurement conditions	Min.	Typ.	Max.	Units
Input current (OFF)	I <sub>DDoff1</sub>	V <sub>CE1</sub> =V <sub>CE2</sub> =0V		0.1	2.0	μA
<b>Voltage regulator 1</b>						
No-Load input current 1	I <sub>DD1</sub>	V <sub>CE1</sub> =V <sub>DD</sub> , V <sub>CE2</sub> =0V I <sub>O1</sub> =0mA		45	70	μA
Output voltage 1	V <sub>O1</sub>	1mA ≤ I <sub>O1</sub> ≤ 30mA	×0.98		×1.02	V
Line regulation 1	V <sub>LINE1</sub>	V <sub>DD</sub> =V <sub>O1</sub> (typ.) +0.5~6V, I <sub>O1</sub> =30mA (V <sub>O1</sub> ≤ 1.6V, V <sub>DD</sub> =2.2~6V)		0.02	0.10	%/V
Load regulation 1	V <sub>LOAD1</sub>	1mA ≤ I <sub>O1</sub> ≤ 150mA		22	40	mV
Dropout voltage 1	V <sub>IO1</sub>	Please refer to Electrical Characteristics 2.				V
Ripple rejection 1-1 *note2	RR1-1	f=1kHz, V <sub>ripple</sub> =0.5V, I <sub>O1</sub> =30mA (V <sub>O1</sub> ≤ 1.7V, V <sub>DD</sub> =V <sub>O1</sub> +1.2V)		70		dB
Ripple rejection 1-2 *note2	RR1-2	f=10kHz, V <sub>ripple</sub> =0.5V, I <sub>O1</sub> =30mA (V <sub>O1</sub> ≤ 1.7V, V <sub>DD</sub> =V <sub>O1</sub> +1.2V)		60		dB

\*note2 : The parameter is guaranteed by design.

**Electrical Characteristics 1** (Except where noted otherwise Ta=25°C, V<sub>DD</sub>=V<sub>OUT</sub> (typ.)+1V, V<sub>CE</sub>=V<sub>DD</sub>)

Item	Symbol	Measurement conditions	Min.	Typ.	Max.	Units
Vo1 temperature coefficient *note2	$\Delta V_{o1} / \Delta T$	I <sub>o1</sub> =30mA -40 ≤ Top ≤ 85°C		±100		ppm/°C
Output noise voltage 1 *note2	V <sub>n1</sub>	f <sub>BW</sub> =10~100kHz		30		μV <sub>rms</sub>
Output short-circuit current 1 *note2	I <sub>lim1</sub>	V <sub>o1</sub> =0V		40		mA
CE1 pull-down resistance	R <sub>pd1</sub>		0.7	2	8	MΩ
CE1 high threshold voltage	V <sub>CE1H</sub>		1.5		V <sub>DD</sub>	V
CE1 low threshold voltage	V <sub>CE1L</sub>		0		0.3	V
Output NMOS ON resistance 1	R <sub>DON1</sub>	V <sub>CE1</sub> =0V V <sub>DD</sub> =4V (V <sub>o1</sub> <3V)		60		Ω
<b>Voltage regulator 2</b>						
No-Load input current 2	I <sub>DD2</sub>	V <sub>CE2</sub> =V <sub>DD</sub> , V <sub>CE1</sub> =0V I <sub>o1</sub> =0mA		45	70	μA
Output voltage 2	V <sub>o2</sub>	1mA ≤ I <sub>o2</sub> ≤ 30mA	×0.98		×1.02	V
Line regulation 2	V <sub>LINE2</sub>	V <sub>DD</sub> =V <sub>o2</sub> (typ.) +0.5~6V, I <sub>o2</sub> =30mA (V <sub>o2</sub> ≤ 1.6V, V <sub>DD</sub> =2.2~6V)		0.02	0.10	%/V
Load regulation 2	V <sub>LOAD2</sub>	1mA ≤ I <sub>o1</sub> ≤ 150mA		22	40	mV
Dropout voltage 2	V <sub>io2</sub>	Please refer to Electrical Characteristics 2.				V
Ripple rejection 2-1 *note2	RR2-1	f=1kHz, V <sub>ripple</sub> =0.5V, I <sub>o2</sub> =30mA (V <sub>o2</sub> ≤ 1.7V, V <sub>DD</sub> =V <sub>o2</sub> +1.2V)		70		dB
Ripple rejection 2-2 *note2	RR2-2	f=10kHz, V <sub>ripple</sub> =0.5V, I <sub>o2</sub> =30mA (V <sub>o2</sub> ≤ 1.7V, V <sub>DD</sub> =V <sub>o2</sub> +1.2V)		60		dB
Vo2 temperature coefficient *note2	$\Delta V_{o2} / \Delta T$	I <sub>o2</sub> =30mA -40 ≤ Top ≤ 85°C		±100		ppm/°C
Output noise voltage 2 *note2	V <sub>n2</sub>	f <sub>BW</sub> =10~100kHz		30		μV <sub>rms</sub>
Output short-circuit current 2 *note2	I <sub>lim2</sub>	V <sub>o2</sub> =0V		40		mA
CE2 pull-down resistance	R <sub>pd2</sub>		0.7	2	8	MΩ
CE2 high threshold voltage	V <sub>CE2H</sub>		1.5		V <sub>DD</sub>	V
CE2 low threshold voltage	V <sub>CE2L</sub>		0		0.3	V
Output NMOS ON resistance 2	R <sub>DON2</sub>	V <sub>CE1</sub> =0V V <sub>DD</sub> =4V (V <sub>o2</sub> <3V)		60		Ω

\*note2 : The parameter is guaranteed by design.

**Electrical Characteristics 2** (Except where noted otherwise Ta=25°C, VDD=Vo (typ.)+1V, VCE=VDD)

Output voltage Vo1, Vo2	Item							
	Output voltage				Dropout voltage			
	Vo1, Vo2 (V)				Vio1, Vio2 (V)			
	Measurement conditions	Min.	Typ.	Max.	Measurement conditions	Min.	Typ.	Max.
1.2V	1mA ≤ Io ≤ 30mA	1.170	1.200	1.230	*note2			
1.3V		1.270	1.300	1.330				
1.4V		1.370	1.400	1.430				
1.5V		1.470	1.500	1.530	Io=150mA		0.38	0.70
1.6V		1.568	1.600	1.632			0.36	0.65
1.7V		1.666	1.700	1.734			0.34	0.60
1.8V		1.764	1.800	1.836	1.8V ≤ Vo ≤ 2.0V Io=150mA		0.32	0.55
1.9V		1.862	1.900	1.938				
2.0V		1.960	2.000	2.040				
2.1V		2.058	2.100	2.142	2.1V ≤ Vo ≤ 2.7V Io=150mA			
2.2V		2.156	2.200	2.244				
2.3V		2.254	2.300	2.346				
2.4V		2.352	2.400	2.448			0.28	0.50
2.5V		2.450	2.500	2.550				
2.6V		2.548	2.600	2.652				
2.7V		2.646	2.700	2.754				
2.8V		2.744	2.800	2.856	2.5V ≤ Vo ≤ 5.0V Io=150mA			
2.9V		2.842	2.900	2.958				
3.0V		2.940	3.000	3.060				
3.1V		3.038	3.100	3.162				
3.2V		3.136	3.200	3.264				
3.3V		3.234	3.300	3.366				
3.4V		3.332	3.400	3.468				
3.5V		3.430	3.500	3.570				
3.6V		3.528	3.600	3.672				
3.7V		3.626	3.700	3.774				
3.8V		3.724	3.800	3.876				
3.9V		3.822	3.900	3.978			0.22	0.35
4.0V		3.920	4.000	4.080				
4.1V		4.018	4.100	4.182				
4.2V	4.116	4.200	4.284					
4.3V	4.214	4.300	4.386					
4.4V	4.312	4.400	4.488					
4.5V	4.410	4.500	4.590					
4.6V	4.508	4.600	4.692					
4.7V	4.606	4.700	4.794					
4.8V	4.704	4.800	4.896					
4.9V	4.802	4.900	4.998					
5.0V	4.900	5.000	5.100					

\*note2 : The parameter is not guaranteed in the model less than Vo=1.4V.

Measuring Circuit

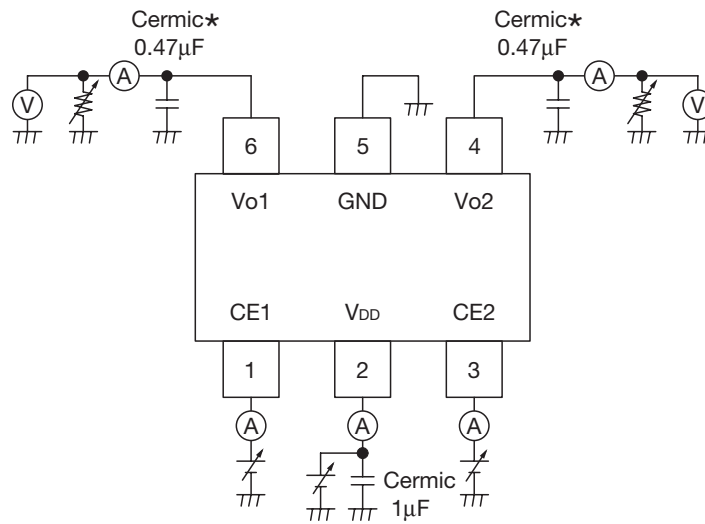

Application Circuit

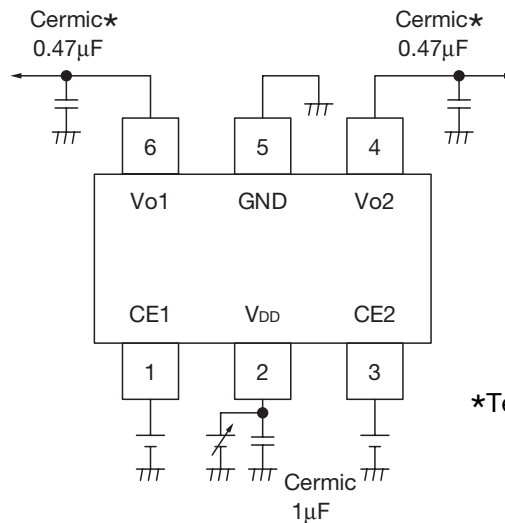

\*Temperature Characteristics : B

(reference example of external parts)

- Output capacitor Ceramic capacitor 0.47µF
- Input Capacitor Ceramic capacitor 1.0µF

Note

note1 : The output capacitor is required between output and GND to prevent oscillation.

note2 : The ESR of capacitor must be defined in ESR stability area.

It is possible to use a ceramic capacitor without ESR resistance for output.

The ceramic capacitor must be used more than 1.0µF or 0.47µF and B temperature characteristics.

note3 : The wire of V<sub>CC</sub> and GND is required to print full ground plane for noise and stability.

note4 : The input capacitor must be connected a distance of less than 1 cm from input pin.

note5 : In case the output voltage is above the input voltage, the overcurrent flow by internal parasitic diode from output to input.

**Characteristics** ( $V_o=2.8V$  Except where noted otherwise  $T_a=25^\circ C$ ,  $V_{DD}=V_{OUT} (typ.)+1V$ ,  $V_{CE}=V_{DD}$ )

■ Output - Input voltage

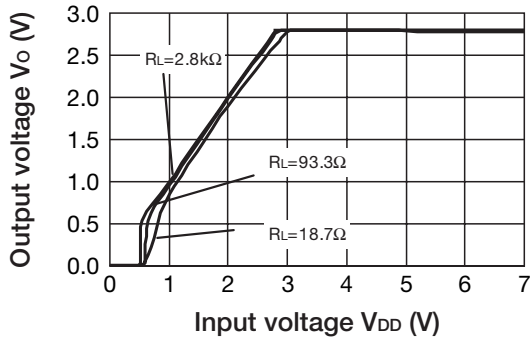

■ Input current - Input voltage

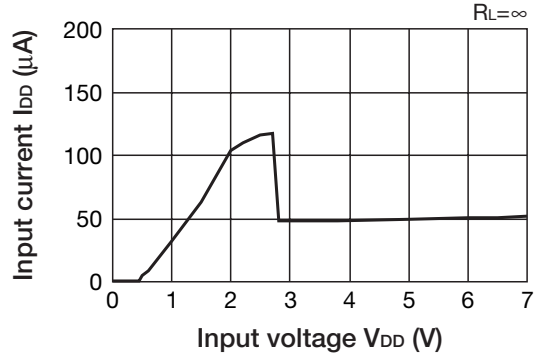

■ Load regulation

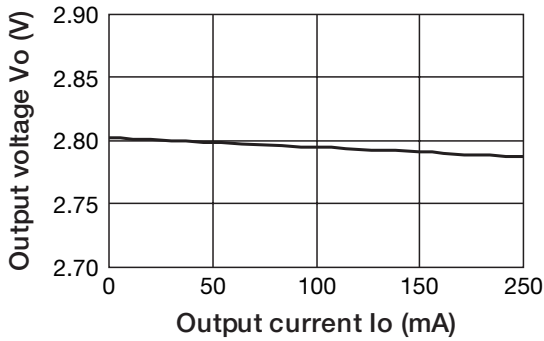

■ Line Regulation

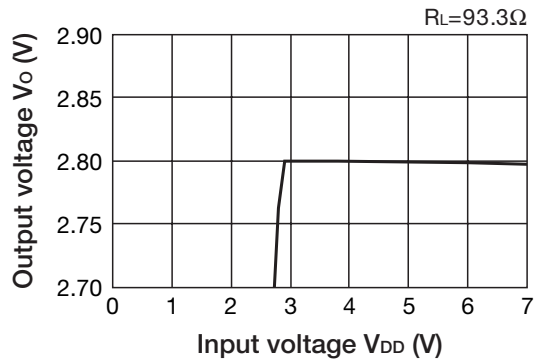

■ Output voltage - Ambient temperature

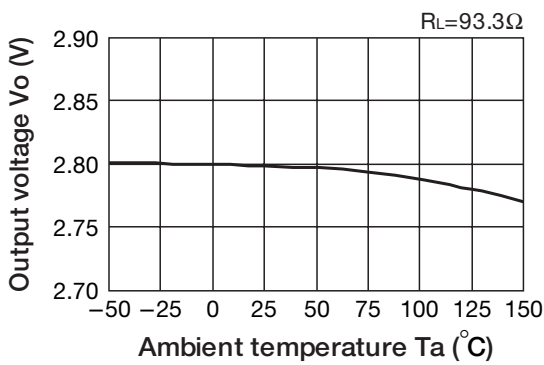

■ Dropout voltage

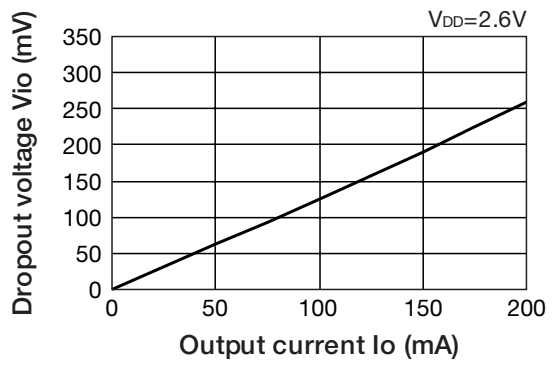

■ Output voltage - Output current

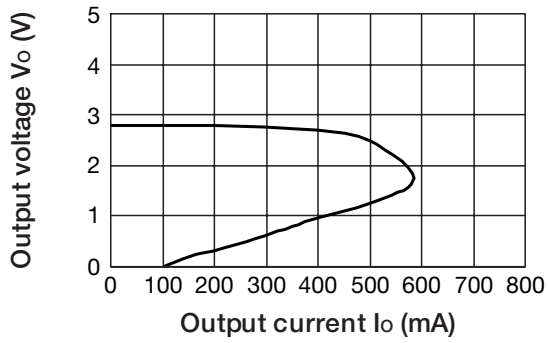

■ Ripple rejection

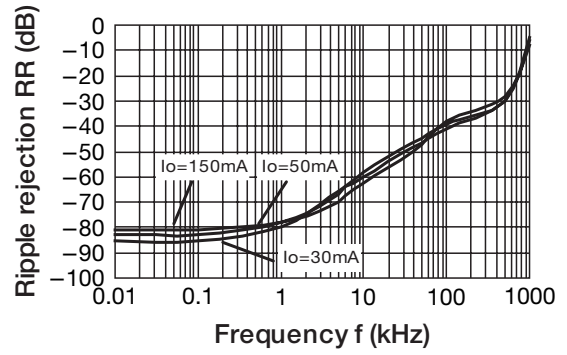

■ ESR Stable area

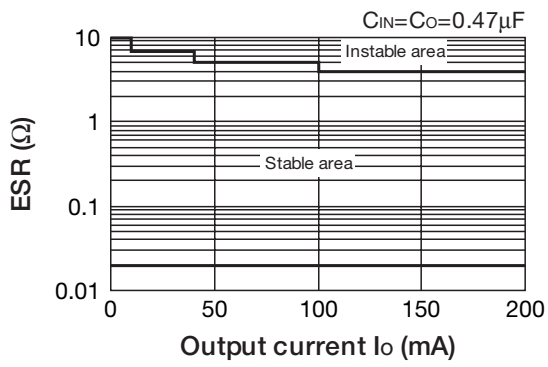

■ Turn-On & Turn Off Transient Response

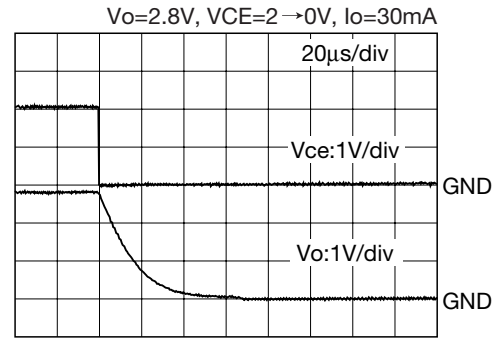
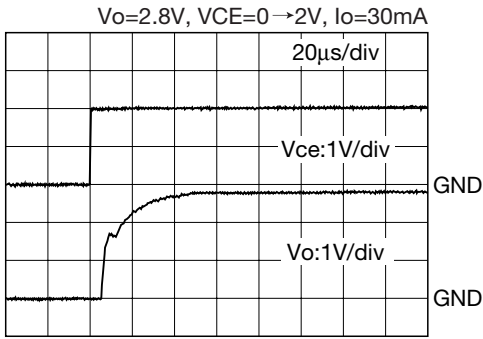

■ Load transient response ( $I_o=10 \rightarrow 50mA$ )

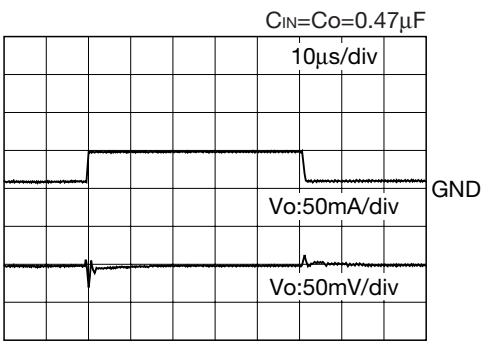

■ Load transient response ( $I_o=10 \rightarrow 100mA$ )

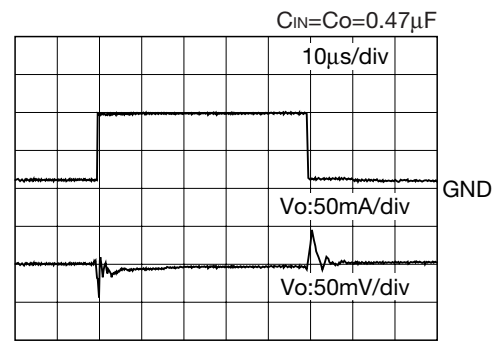

■ Load transient response ( $I_o=10 \rightarrow 150mA$ )

