

Low-Saturation voltage 1.5A LDO Monolithic IC MM185x Series

Outline

This IC is a 1.5A LDO with a low saturation voltage.

In addition to a low-saturation voltage (0.26V typ., $I_o=1.5\text{ A}$), the device has a low voltage output with a minimum of 0.9 V, and is therefore capable of low-voltage operation.

This device is offered in the PKG TO-252-5 package featuring high heat dissipation and the small-sized PKG HSOP-8 package.

For protection, it includes an over-current protection circuit and a thermal shutdown circuit.

Features

1. Supply Current	1mA typ. (No-Load)
2. Supply Current	1 μ A max. (OFF)
3. Output Voltage Range	0.9V~5.0V
4. Output Voltage accuracy	$\pm 2\%$
5. Dropout Voltage	0.26V typ. ($I_o=1.5\text{ A}$)
6. Line Regulation	10mV typ. ($V_o+0.5\text{ V}\sim V_o+1.5\text{ V}$)
7. Load Regulation	19mV typ. ($I_o=0\sim 1.5\text{ A}$)
8. Ripple rejection	65dB typ. ($f=1\text{ kHz}$)
9. Thermal shutdown	
10. Input & Output Capacitor	1 μ F

Package

TO-252-5A
HSOP-8A

Applications

1. TV
2. Blu-ray / DVD recorder, STB

Block Diagram

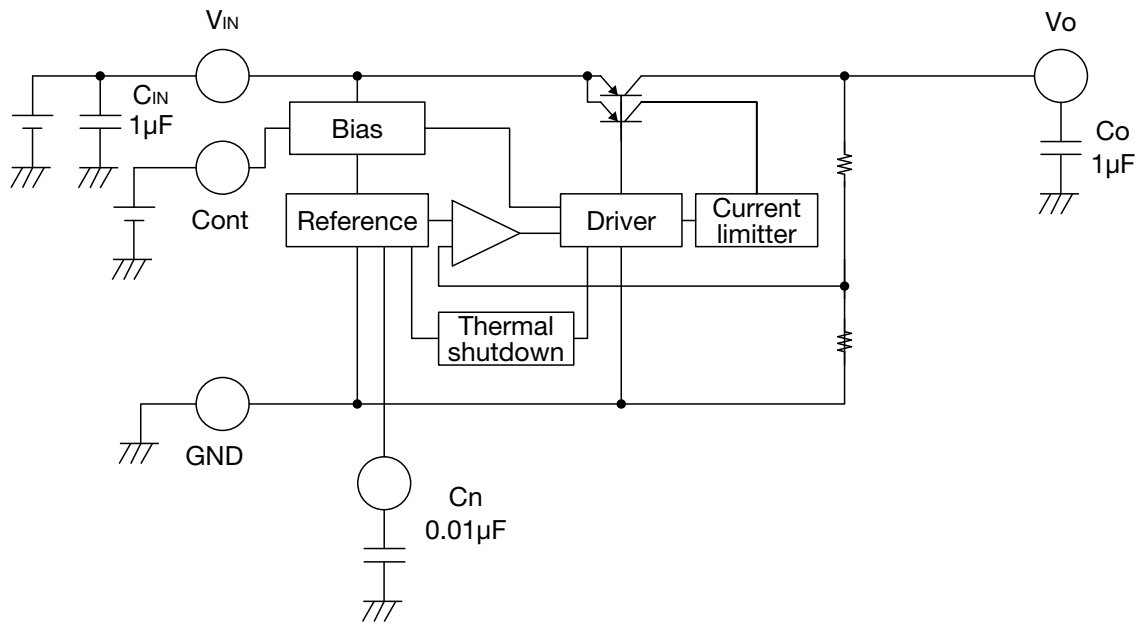

Pin Assignment

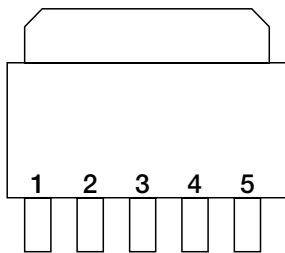

TO-252-5A
(TOP VIEW)

1	Cont
2	V _{IN}
3	GND
4	C _n
5	V _O

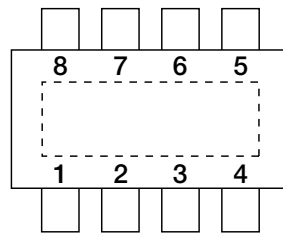

HSOP-8A
(TOP VIEW)

1	V _{OUT}
2	NC
3	GND
4	C _n
5	Cont
6	NC
7	NC
8	V _{IN}

Pin Description

TO-252-5A

Pin No.	Pin name	Functions	Internal equivalent circuit diagram						
1	Cont	Control pin <table border="1"> <tr> <td>Cont</td> <td>Output</td> </tr> <tr> <td>Low</td> <td>OFF</td> </tr> <tr> <td>High</td> <td>ON</td> </tr> </table>	Cont	Output	Low	OFF	High	ON	
Cont	Output								
Low	OFF								
High	ON								
2	V _{IN}	Input pin The capacitor is required to connect with input pin more than 1μF							
3	GND	Ground							
4	C _n	Noise decrease pin Connecting 0.01μF capacitor can decrease output noise. If the noise decrease capacitor is not connected, the pin may be influenced by outside noise.							
5	V _{OUT}	Output pin The capacitor must be connected with output pin more than 1μF.							

■ HSOP-8A

Pin No.	Pin name	Functions	Internal equivalent circuit diagram						
1	V _{OUT}	Output pin The capacitor must be connected with output pin more than 1μF.							
2	NC	No connection							
3	GND	Ground							
4	C _n	Noise decrease pin Connecting 0.01μF capacitor can decrease output noise. If the noise decrease capacitor is not connected, the pin may be influenced by outside noise.							
5	Cont	Control pin <table border="1"> <thead> <tr> <th>Cont</th> <th>Output</th> </tr> </thead> <tbody> <tr> <td>Low</td> <td>OFF</td> </tr> <tr> <td>High</td> <td>ON</td> </tr> </tbody> </table>	Cont	Output	Low	OFF	High	ON	
Cont	Output								
Low	OFF								
High	ON								
6	NC	No connection							
7	NC	No connection							
8	V _{IN}	Input pin The capacitor is required to connect with input pin more than 1μF							

Absolute Maximum Ratings (Except where noted otherwise Ta=25°C)

Item	Symbol	Ratings	Units
Storage Temperature	T _{STG}	-40~+150	°C
Supply Voltage	V _{IN}	-0.3~+12	V
Max Output Current	I _{OUT max.}	1.8	A
Power Dissipation	P _d	2500(Note1)	TO-252-5A
		1800(Note2)	HSOP-8A

Note1 : With the double sided PC Board of glass epoxy
(Copper plane 80%, 150 × 100 × 1.0⁺mm)

Note2 : With the double sided PC Board of glass epoxy
(Copper plane 80%, 37 × 37 × 1.6⁺mm)

Recommended Operating Conditions (Except where noted otherwise Ta=25°C)

Item	Symbol	Ratings	Units
Operating Temperature	T _{OPR}	-40~+85	°C
Output Current	I _{OUT}	0~1.5	A
Operating Voltage	V _{OP}	V _O (typ.)+0.3~+10(Note3)	V

Note3 : The Operating Voltage is (V_O+0.35V)~10V in the model less than V_{OUT}=1V.

Electrical Characteristics 1 (Except where noted otherwise V_{IN}=V_O+0.5V, V_{Cont}=0.8V, I_O=1mA, Ta=25°C)

Item	Symbol	Measurement conditions	Min.	Typ.	Max.	Units
No-Load Input Current	I _{CC}	I _O =0mA		1	2	mA
Input Current(OFF)	I _{CCOFF}	V _{Cont} =0V		0	1	μA
Output Voltage (Note5)	V _{OUT}		×0.98		×1.02	V
Dropout Voltage (Note4, 6)	V _{IO}	V _{IN} =V _{OUT} -0.1V, I _O =1.5A		0.26	0.38	V
Line Regulation	ΔV ₁	V _{IN} =V _O +0.5~V _O +1.5V, I _O =1mA		10	20	mV
Load Regulation(Note4)	ΔV ₂	I _O =0~1.5A		19	50	mV
V _{OUT} Temperature Coefficient (Note4)	ΔV _{OUT} /ΔT	T _j =-40~+85°C		100		ppm/°C
Ripple Rejection (Note4)	RR	f=1kHz V _{ripple} =0.5V, I _O =250mA	50	65		dB
Output Noise Voltage (Note4)	V _n	f _{BW} =20~80kHz C _n =0.01μF		60		μV _{rms}
		f _{BW} =20~80kHz C _n =OPEN		150		
Cont Pin Input Current (Note7)	I _{Cont}			0.3	0.6	μA
Cont Pin High Threshold Level	V _{ContH}		0.8		10	V
Cont Pin Low Threshold Level	V _{ContL}		-0.3		0.2	V

Note4 : The parameter is guaranteed by design.

Note5 : Please refer to another page.

Note6 : The parameter is not guaranteed in the model less than V_{OUT}=1V.

Note7 : Please refer to 'TYPICAL PERFORMANCE CHARACTERISTICS'.

Electrical Characteristics 2 (Except where noted otherwise $V_{IN}=V_O+0.5V$, $I_O=1mA$, $T_a=25^\circ C$)

Model No.	Measurement Conditions	Output Voltage		
		Min.	Typ.	Max.
MM1850K	$V_{IN}=V_O+0.5V$ $I_O=1mA$	0.870	0.90	0.930
MM1851A		0.970	1.00	1.030
MM1851B		1.070	1.10	1.130
MM1851C		1.170	1.20	1.230
MM1851D		1.270	1.30	1.330
MM1851E		1.370	1.40	1.430
MM1851F		1.470	1.50	1.530
MM1851G		1.568	1.60	1.632
MM1851H		1.666	1.70	1.734
MM1851J		1.764	1.80	1.836
MM1851K		1.862	1.90	1.938
MM1852A		1.960	2.00	2.040
MM1852B		2.058	2.10	2.142
MM1852C		2.156	2.20	2.244
MM1852D		2.254	2.30	2.346
MM1852E		2.352	2.40	2.448
MM1852F		2.450	2.50	2.550
MM1852G		2.548	2.60	2.652
MM1852H		2.646	2.70	2.754
MM1852J		2.744	2.80	2.856
MM1852K		2.842	2.90	2.958
MM1853A		2.940	3.00	3.060
MM1853B		3.038	3.10	3.162
MM1853C		3.136	3.20	3.264
MM1853D		3.234	3.30	3.366
MM1853E		3.332	3.40	3.468
MM1853F		3.430	3.50	3.570
MM1853G		3.528	3.60	3.672
MM1853H		3.626	3.70	3.774
MM1853J		3.724	3.80	3.876
MM1853K		3.822	3.90	3.978
MM1854A		3.920	4.00	4.080
MM1854B		4.018	4.10	4.182
MM1854C		4.116	4.20	4.284
MM1854D		4.214	4.30	4.386
MM1854E		4.312	4.40	4.488
MM1854F		4.410	4.50	4.590
MM1854G		4.508	4.60	4.692
MM1854H		4.606	4.70	4.794
MM1854J		4.704	4.80	4.896
MM1854K	4.802	4.90	4.998	
MM1855A	4.900	5.00	5.100	

• Any products mentioned in this catalog are subject to any modification in their appearance and others for improvements without prior notification.
 • The details listed here are not a guarantee of the individual products at the time of ordering. When using the products, you will be asked to check their specifications.

Measuring Circuit

■ HSOP-8A

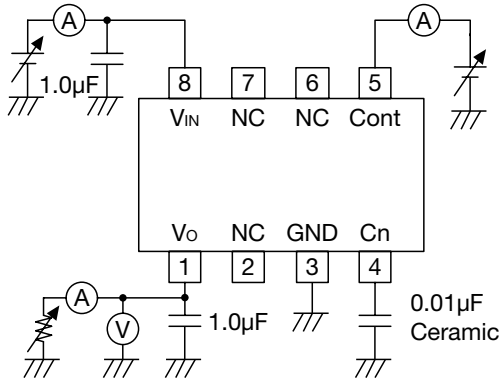

■ TO-252-5A

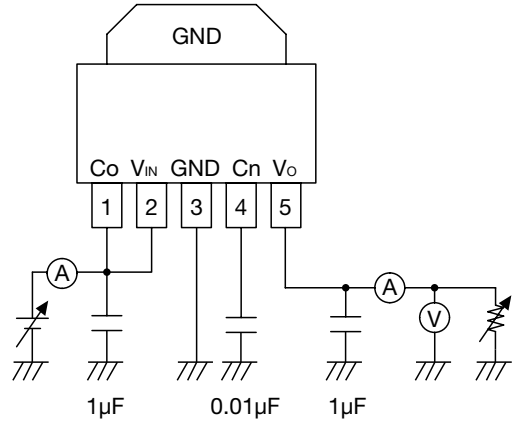

Application Circuit

■ HSOP-8A

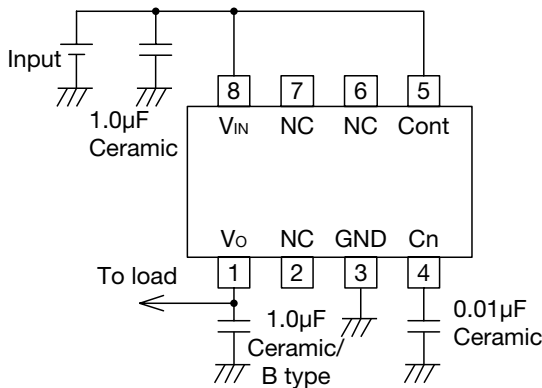

■ TO-252-5A

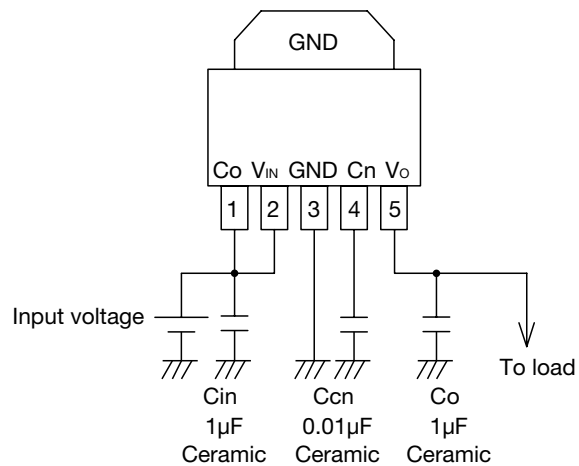

Cin		Cout		Characteristics
Capacity	Kind	Capacity	Kind	
1.0µF or more	Ceramic	1.0µF or more	Ceramic	B type/X5R
2.2µF or more	Ceramic	10µF or more	Ceramic	B type/X5R

· Note

1. The output capacitor is required between output and GND to prevent oscillation.
2. The ESR of capacitor must be defined in ESR stability area.
3. The wire of Vcc and GND is required to print full ground plane for noise and stability.
4. The input capacitor must be connected a distance of less than 1cm from input pin.
5. The capacitor is connected to Cn must have low leakage current characteristics, because Cn pin is high impedance.
6. In case the output voltage is above the input voltage, the overcurrent flow by internal parasitic diode from output to input. In such application, the external bypass diode must be connected between output and input pin.

About Power Dissipation

This IC's GND pin and Heat Spreader Bottom effectively radiate heat. By increasing these copper foil pattern area of PCB, Power dissipation improves. Please kindly design PCB pattern taking care of above features about power dissipation.

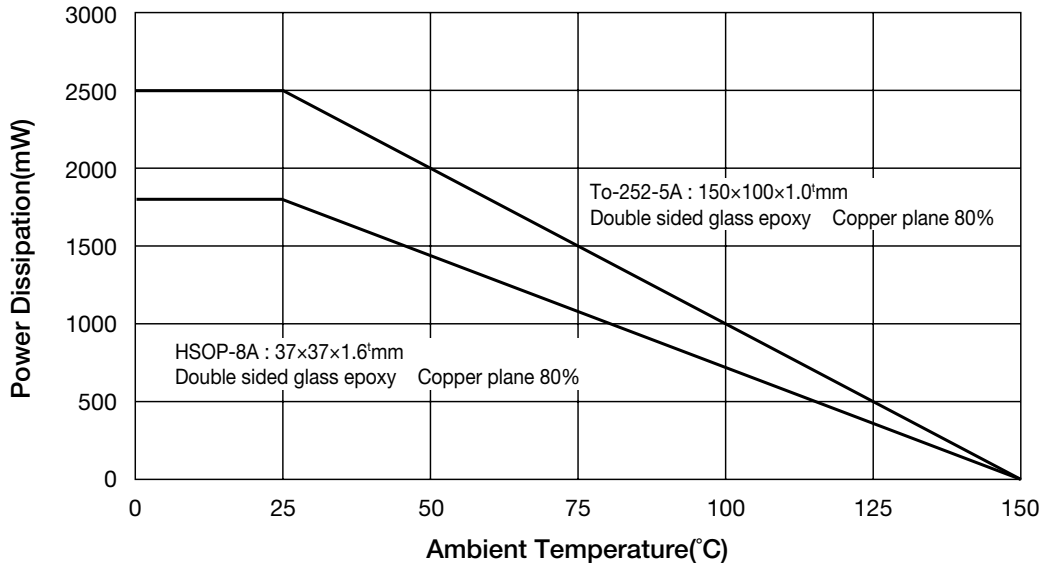

Land Pattern Recommendation

HSOP-8A

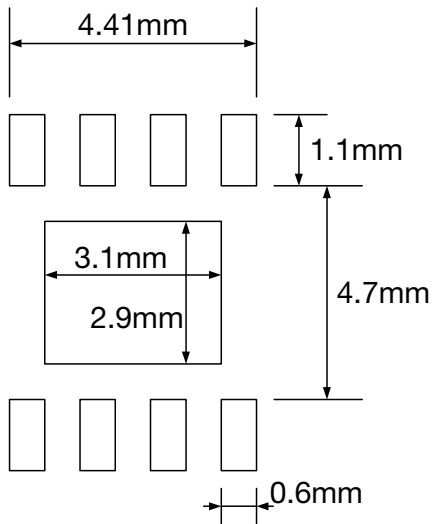

TO-252-5A

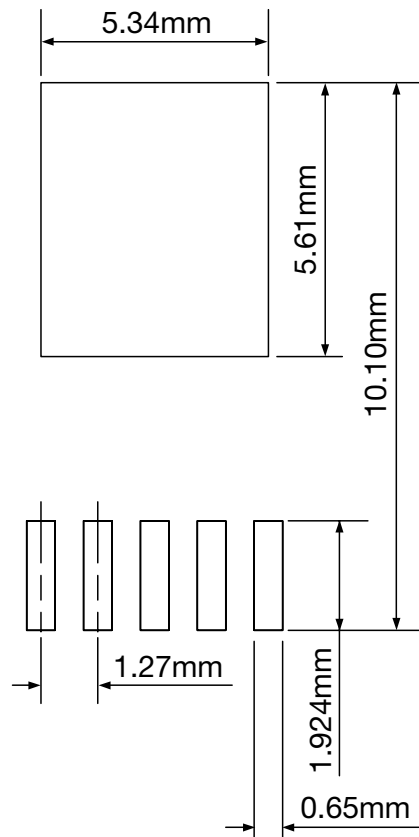

Note : These Dimensions are the reference values.

Characteristics (Vo=1.2V)

(Except where noted otherwise $V_{IN}=V_O+0.5V$, $V_{Cont}=0.8V$, $C_{in}=1.0\mu F$, $C_O=1.0\mu F$, $C_{Cn}=0.01\mu F$, $T_a=25^\circ C$)

Output - Input voltage

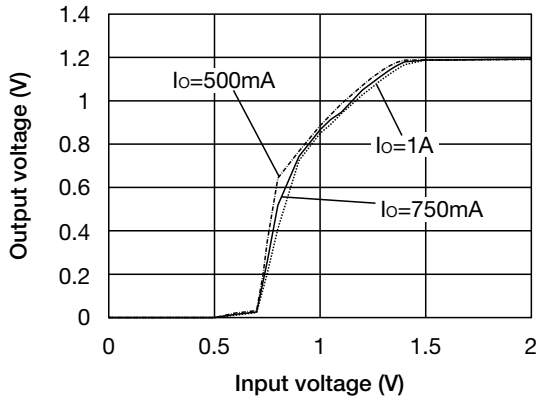

No Load input current

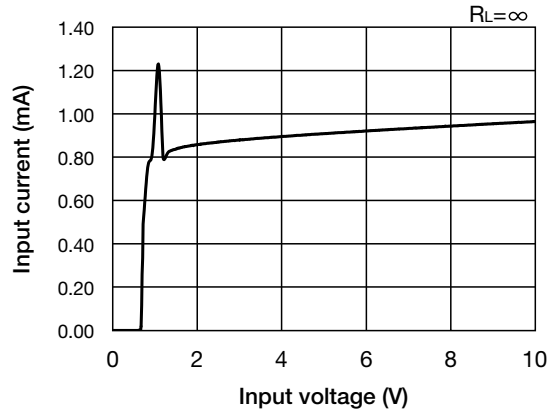

Load regulation

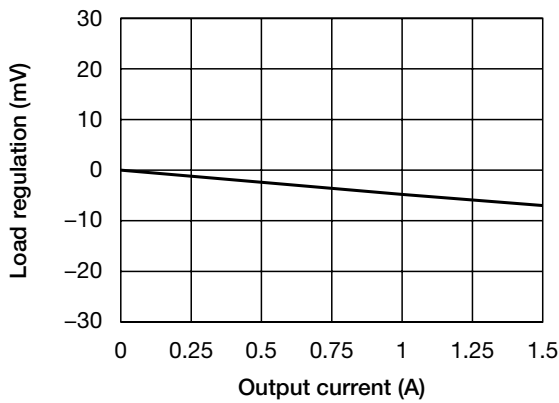

Line regulation

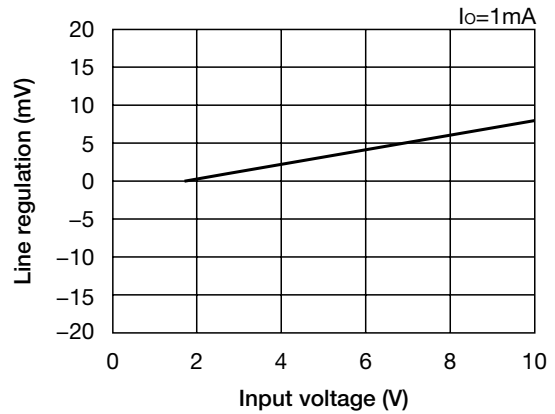

Dropout voltage

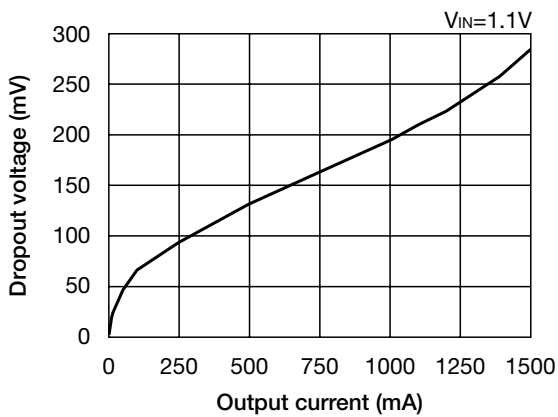

Dropout voltage

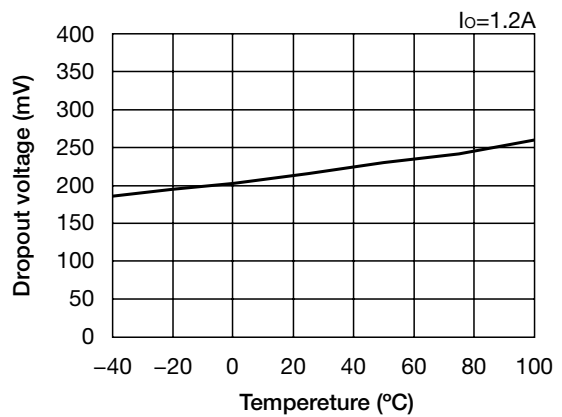

Ripple Rejection

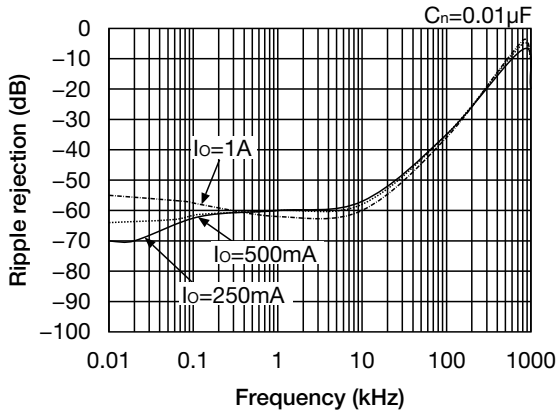

ESR Stable area

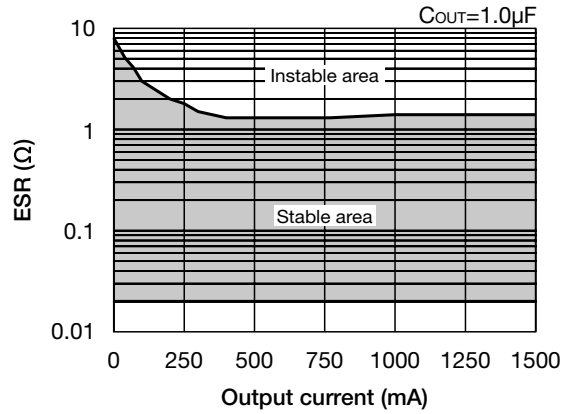

GND PIN Current

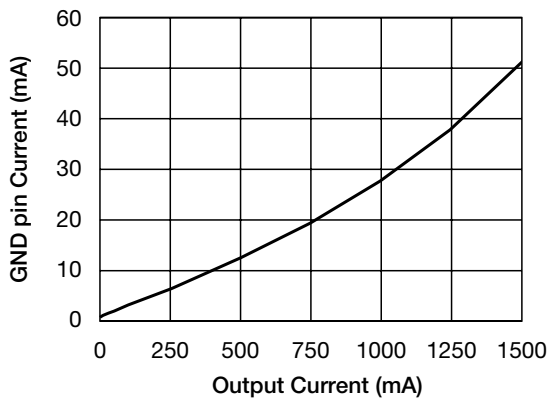

Output voltage - Temperature

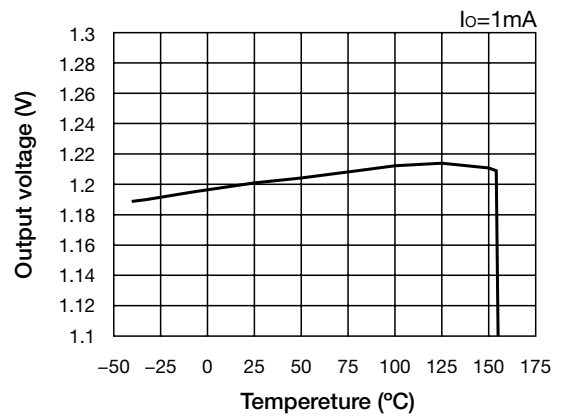

Cont PIN Input current

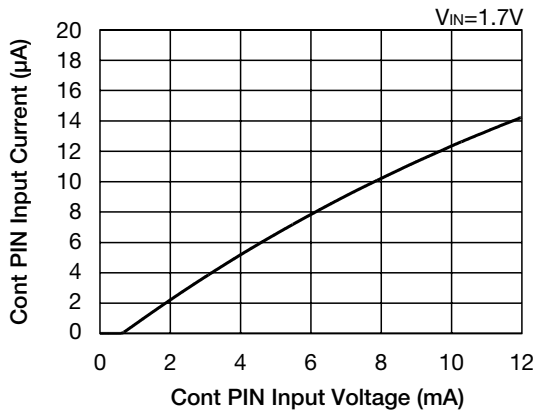

Current limit

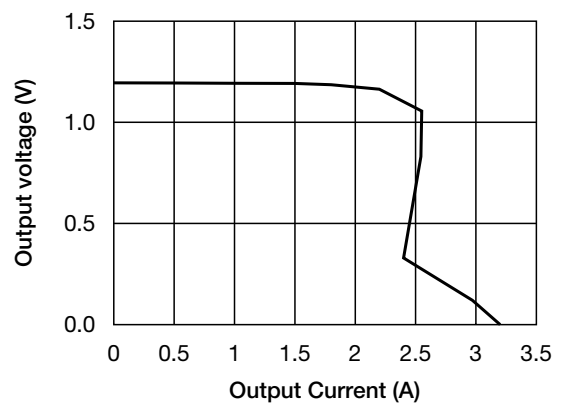

• Any products mentioned in this catalog are subject to any modification in their appearance and others for improvements without prior notification.
 • The details listed here are not a guarantee of the individual products at the time of ordering. When using the products, you will be asked to check their specifications.

Characteristics (Vo=1.8V)

(Except where noted otherwise $V_{IN}=V_O+0.5V$, $V_{Cont}=0.8V$, $C_{in}=1.0\mu F$, $C_O=1.0\mu F$, $C_{Cn}=0.01\mu F$, $T_a=25^\circ C$)

Output - Input voltage

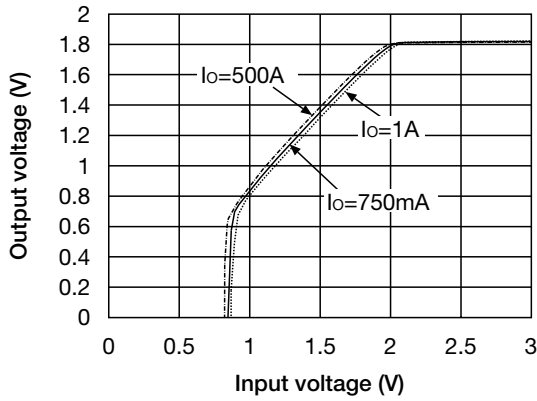

No Load input current

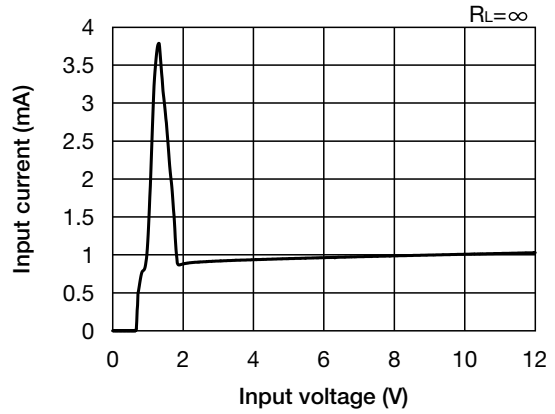

Load regulation

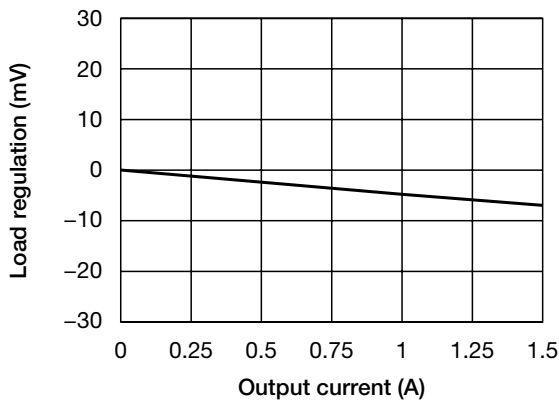

Line regulation

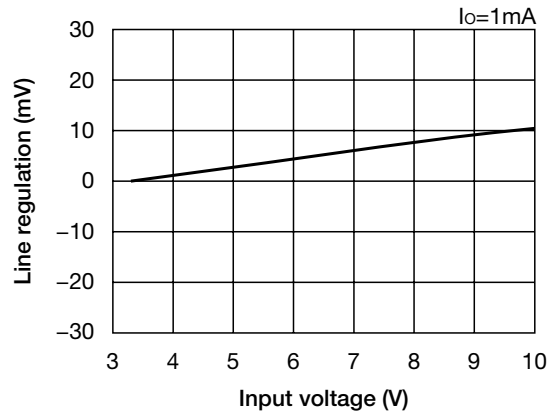

Output voltage - Temperature

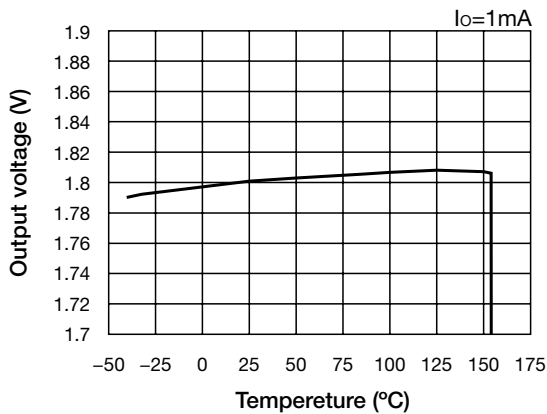

Dropout voltage

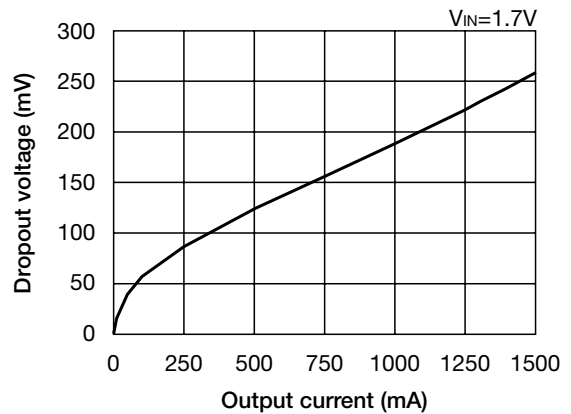

Characteristics (Vo=3.3V)

(Except where noted otherwise $V_{IN}=V_O+0.5V$, $V_{Cont}=0.8V$, $C_{in}=1.0\mu F$, $C_O=1.0\mu F$, $C_{Cn}=0.01\mu F$, $T_a=25^\circ C$)

Output - Input voltage

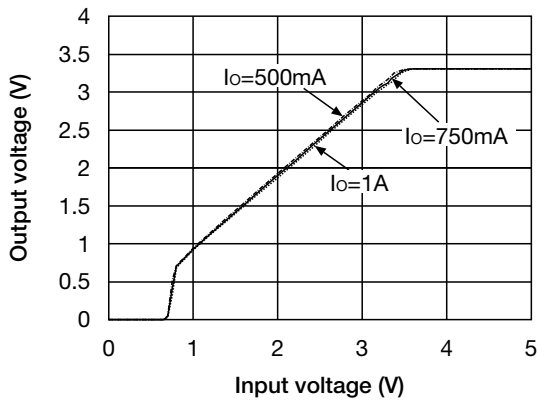

No Load input current

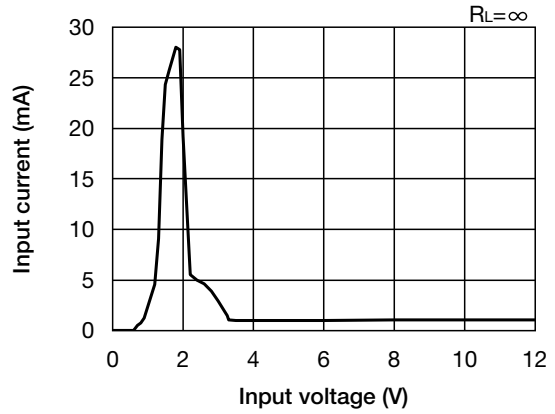

Load regulation

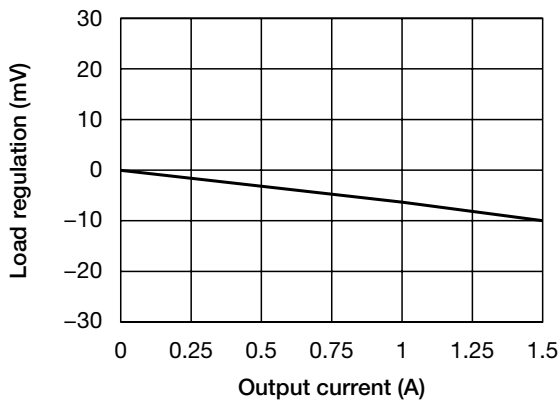

Line regulation

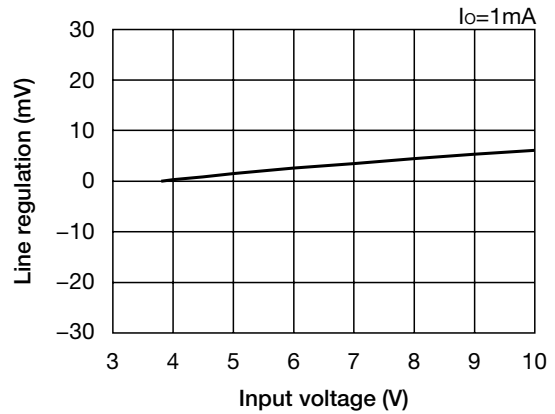

Dropout voltage

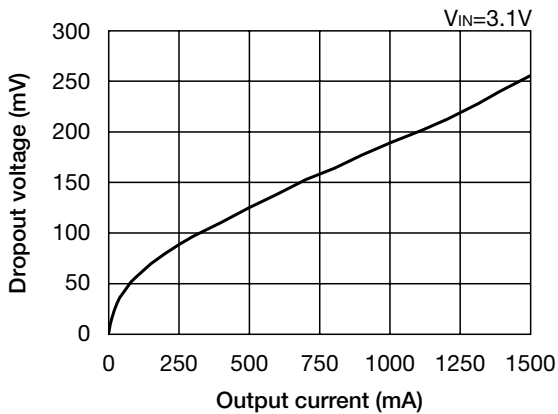

Characteristics (Vo=5.0V) (Except where noted otherwise $V_{IN}=V_o+0.5V$, $V_{Cont}=0.8V$, $C_{in}=1.0\mu F$, $C_o=1.0\mu F$, $C_{Cn}=0.01\mu F$, $T_a=25^\circ C$)

Output - Input voltage

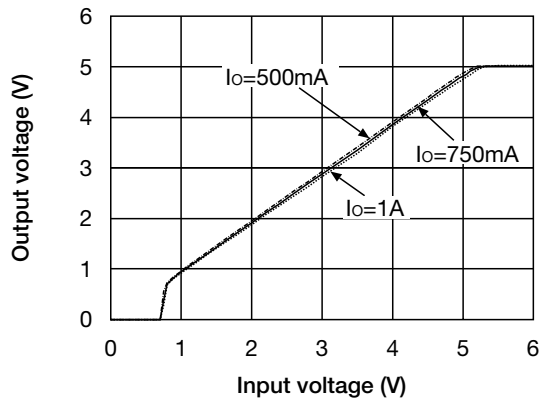

No Load input current

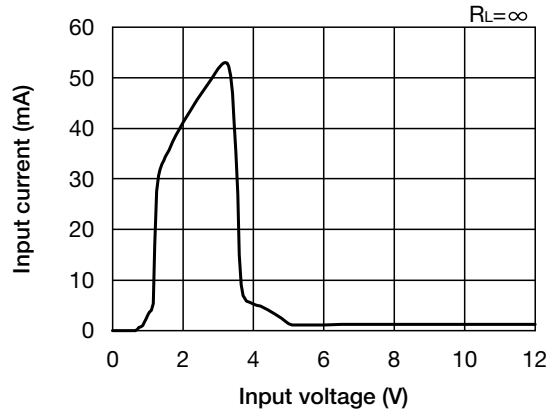

Load regulation

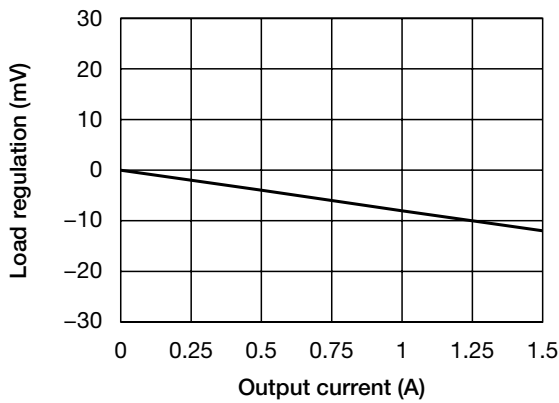

Line regulation

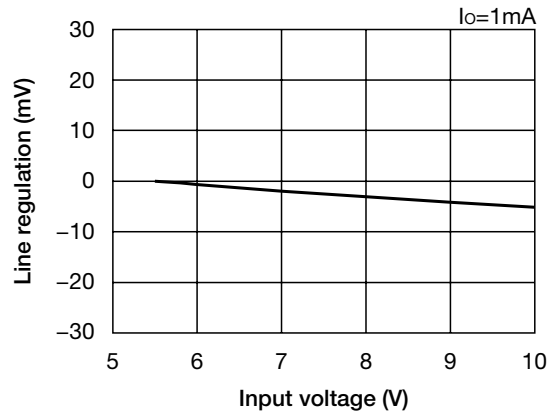

Dropout voltage

