

Multiple Regulator Monolithic IC MM1792□ Series

Outline

This IC has been developed as a multiple-output power supply IC and is composed of three positive voltage regulator circuits. The output voltage of the regulator can be programmed between 1.5V and 5.0V upon request. The output capacitor is a ceramic capacitor.

Features

- | | |
|--|----------------------------|
| 1. Current consumption (no load connected to V_{IN1} and V_{IN2}) | 1.2mA typ. |
| 2. High accuracy output voltage | $\pm 2.0\%$ |
| 3. Dropout voltage | 0.15V typ. ($I_o=100mA$) |
| 4. High ripple rejection | 80dB typ. |
| 5. Operating temperature range | -40 to $+85^\circ C$ |
| 6. Output voltage | 1.5 to 5.0V (0.1V steps) |
| 7. Output capacitor | 1 μF (Ceramic) |

Package

HSOP-8A

Applications

1. Cordless phones
2. Portable equipment
3. DVD equipment

Pin Assignment

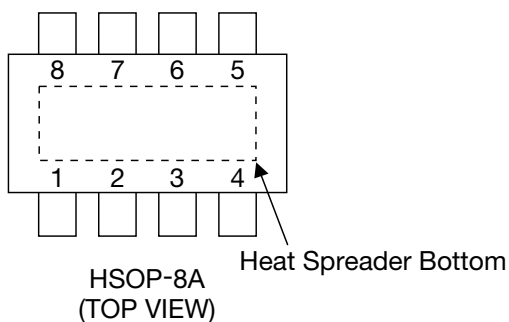

1	V_{o1}
2	V_{o2}
3	GND
4	V_{o3}
5	V_{IN2}
6	NC
7	NC
8	V_{IN1}

Block Diagram

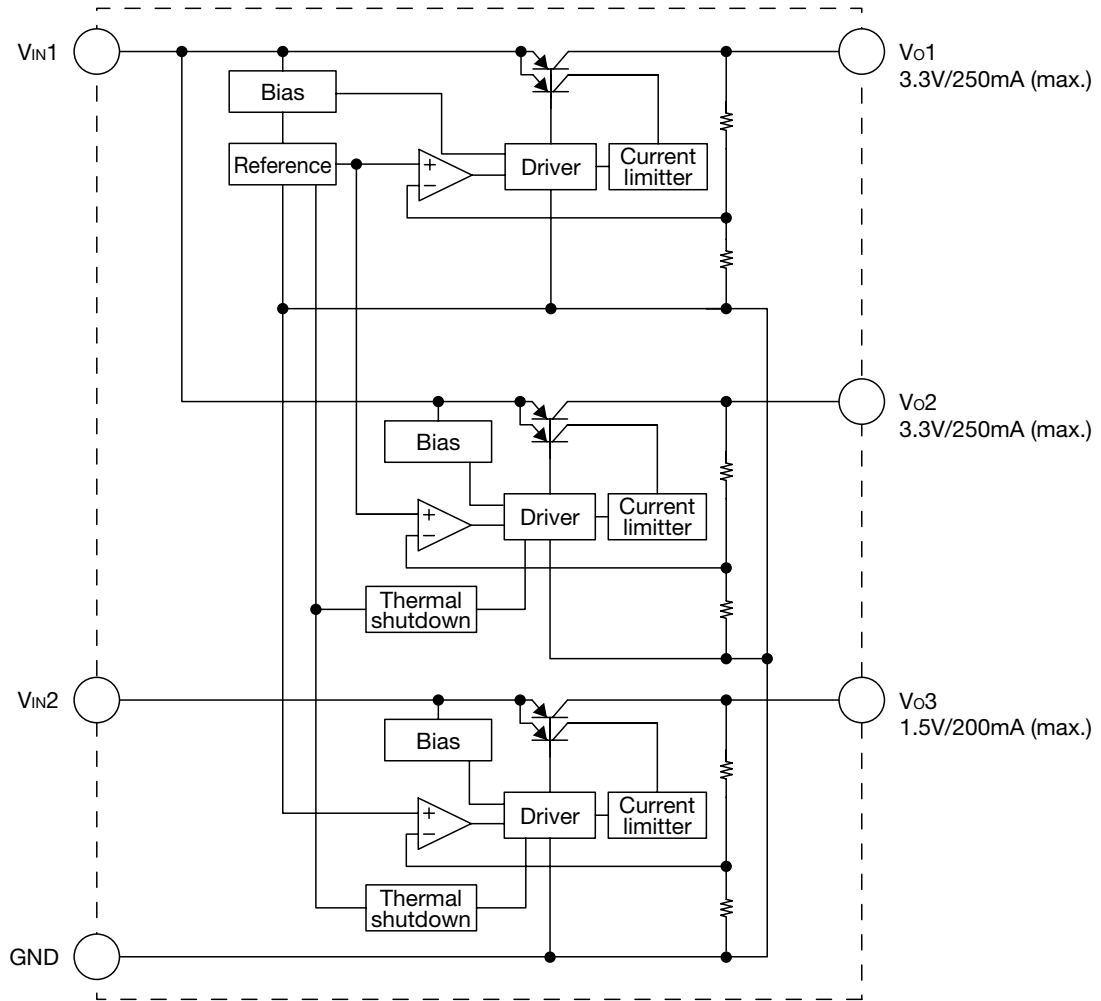

Pin Description

Pin No.	Pin name	Function	Internal equivalent circuit diagram
1 2 4	Vo1 Vo2 Vo3	Output pin The output capacitor is recommended to be 1μF. The capacitor must be connected with the output pin more than 1μF.	
3	GND	Ground	
5 8	V _{IN}	Input pin The capacitor is required to be connected with the input pin about 1μF.	
6 7	NC	No connection	

Absolute Maximum Ratings (Ta=25°C)

Item	Symbol	Ratings	Units
Storage temperature	T _{STG}	-55~+150	°C
Supply voltage	V _{IN}	-0.3~+12	V
Output current 1, 2	I _{OUT1,2}	300	mA
Output current 3	I _{OUT3}	250	mA
Power dissipation	P _d	780 (*1)	mW

Note1: *1 Attached on PC board (40 × 40 × 1.6mm)

Recommended Operating Conditions (Ta=25°C)

Item	Symbol	Ratings	Units
Operating temperature	T _{OPR}	-40~+85	°C
Operating voltage	V _{OP}	Vo 0.5~10	V
Output current 1, 2	I _{OUT1,2}	0~250	mA
Output current 3	I _{OUT3}	0~200	mA

Electrical Characteristics (Except where noted otherwise, Ta=25°C, VIN1=VIN2=Vo (Typ.) +1V, Io1=Io2=Io3=1mA)

Item	Symbol	Measurement conditions	Min.	Typ.	Max.	Units
VIN input current 1	Iccq1	IOUT1=IOUT2=0mA		1	2	mA
VIN input current 2	Iccq2	IOUT3=0mA		0.2	0.6	mA
Regulator 1 (Io1=250mA)						
Output voltage 1	VO1		3.234	3.30	3.366	V
Dropout voltage 1	VIo1	VIN1=3.1V, IOUT1=100mA		0.15	0.3	V
Line regulation 1	ΔV_1	VIN1=4.3~5.3V		1	20	mV
Load regulation 1	ΔV_2	Io1=1~250mA		20	120	mV
Vo temperature coefficient 1 *1	$\Delta V_{O1}/\Delta T$	Tj=-40~+85°C		100		ppm/°C
Ripple rejection 1 *1	RR1	f=1kHz Vripple=1V	50	80		dB
Output noise voltage1 *1	Vn1	fbw=20~80kHz		100		μVrms
Regulator 2 (Io2=250mA)						
Output voltage 2	VO2		3.234	3.30	3.366	V
Dropout voltage 2	VIo2	VIN1=3.1V, IOUT1=100mA		0.15	0.3	V
Line regulation 2	ΔV_2	VIN1=4.3~5.3V		1	20	mV
Load regulation 2	ΔV_2	Io2=1~250mA		20	120	mV
Vo temperature coefficient 2 *1	$\Delta V_{O2}/\Delta T$	Tj=-40~+85°C		100		ppm/°C
Ripple rejection 2 *1	RR2	f=1kHz Vripple=1V	50	80		dB
Output noise voltage2 *1	Vn2	fbw=20~80kHz		100		μVrms
Regulator 3 (Io3=200mA)						
Output voltage 3	VO3		1.47	1.5	1.53	V
Line regulation 3	ΔV_3	VIN2=2.5~3.5V		1	20	mV
Load regulation 3	ΔV_3	Io3=1~200mA		20	120	mV
Vo temperature coefficient 3 *1	$\Delta V_{O3}/\Delta T$	Tj=-40~+85°C		100		ppm/°C
Ripple rejection 3 *1	RR3	f=1kHz Vripple=1V	50	80		dB
Output noise voltage3 *1	Vn3	fbw=20~80kHz		100		μVrms

Note 1: *1 The parameter is guaranteed by design.

Measuring Circuit

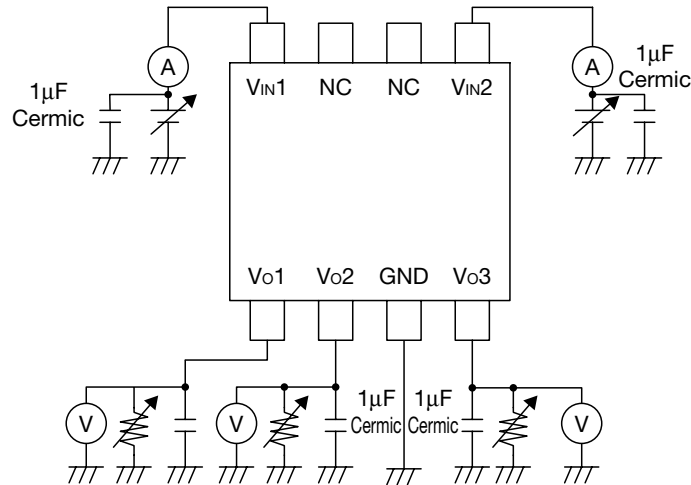

Application Circuit

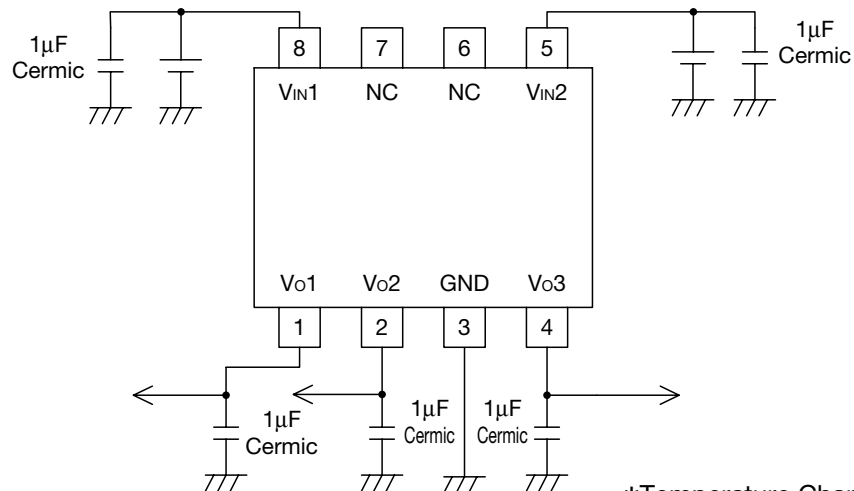

*Temperature Characteristics: B Type

Note

1. The output capacitor is required between output and GND to prevent the oscillation.
2. The output capacitor must be used in ESR stable area.

It is possible to use a ceramic capacitor without ESR resistance for output.

The ceramic capacitor must be used more than 1µF and B type temperature characteristics.

3. The wire of V_{CC} and GND is required to print full ground plane for noise and stability.
4. The input capacitor must be connected in 1cm from input the pin.

Power Dissipation

This IC's GND pin and Heat Spreader Bottom effectively radiate heat. By increasing these copper foil pattern area of PCB, power dissipation improves. Please kindly design PCB pattern taking care of above features about the power dissipation.

Power Dissipation

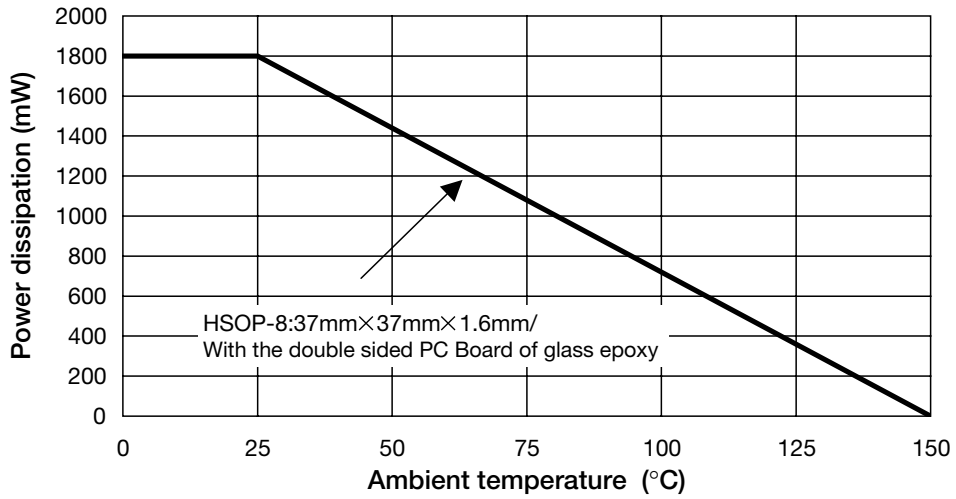

Land Pattern Recommendation

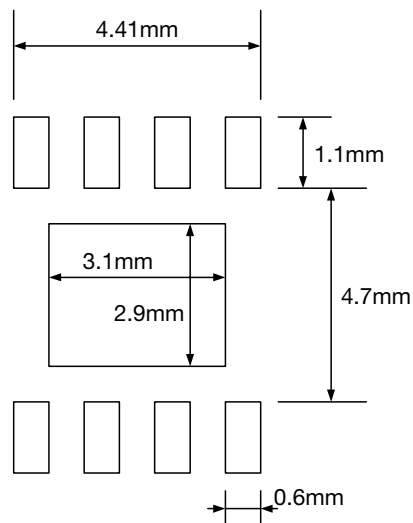

Characteristics (Except where noted otherwise, $T_a=25^\circ\text{C}$, $V_{IN}=5\text{V}$, $C_{IN}=1\mu\text{F}$, $C_o=1\mu\text{F}$)

■ Output Voltage-Input Voltage V_{o1}

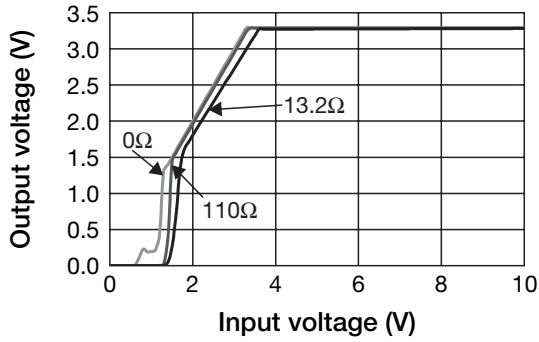

■ Input current-Input Voltage

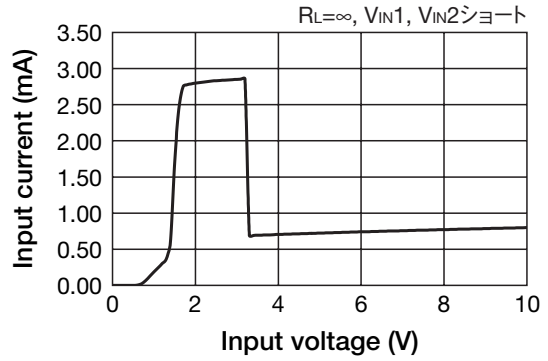

■ Line Regulation V_{o1}

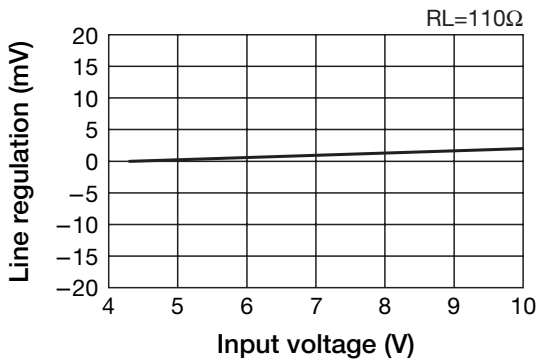

■ Load Regulation V_{o1}

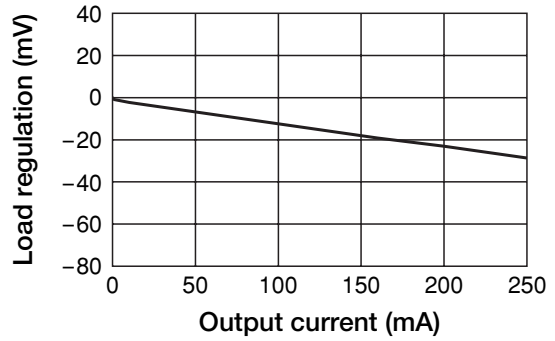

■ Dropout Voltage-Output Current V_{o1}

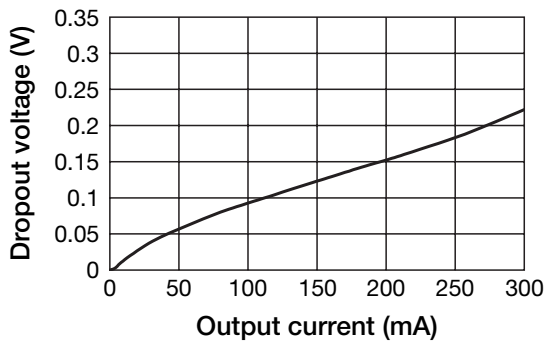

■ V_{o1} Output Voltage-Ambient Temperature

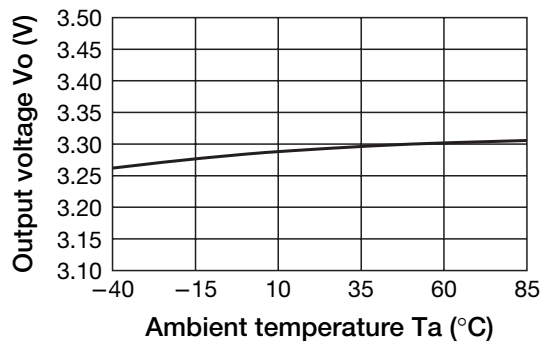

■ Output Voltage-Input Voltage Vo2

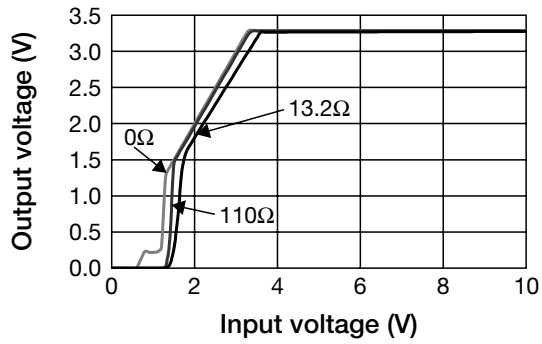

■ Line Regulation Vo2

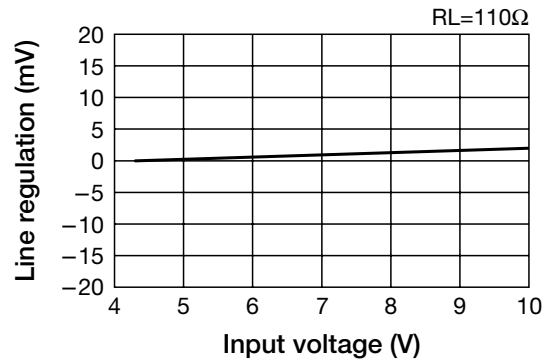

■ Load Regulation Vo2

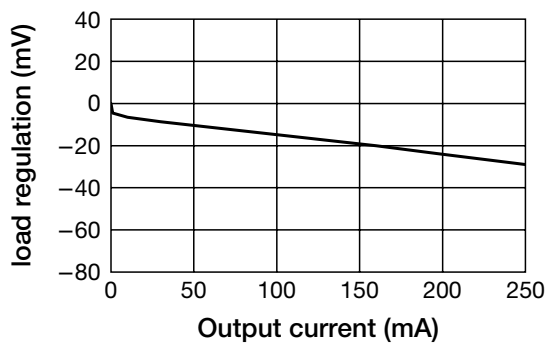

■ Dropout Voltage-Output Current Vo2

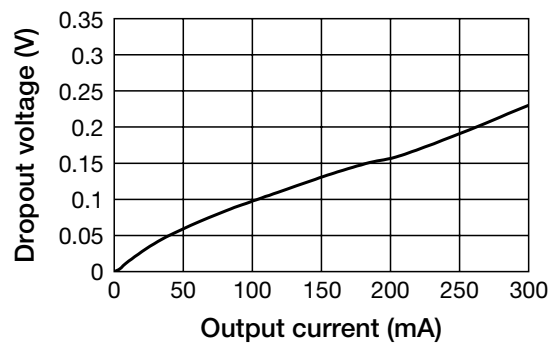

■ Vo2 Output Voltage-Ambient Temperature

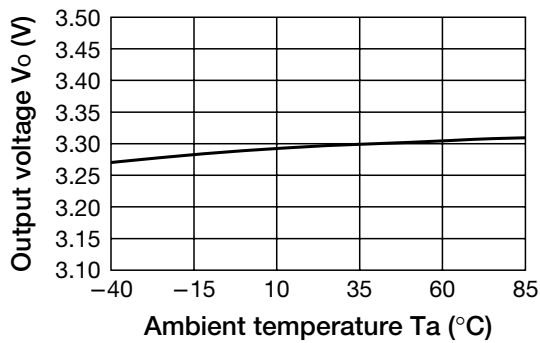

■ Output Voltage-Input Voltage Vo3

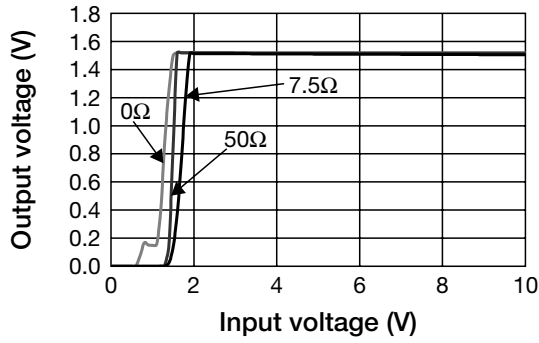

■ Line Regulation Vo3

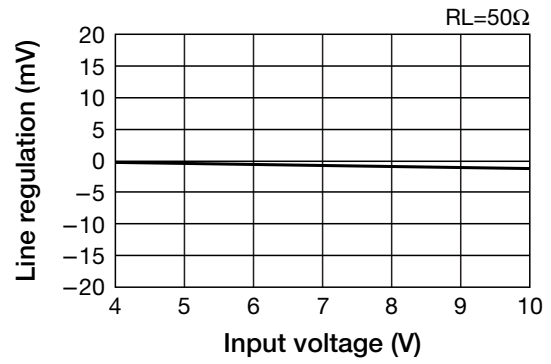

■ Load Regulation Vo3

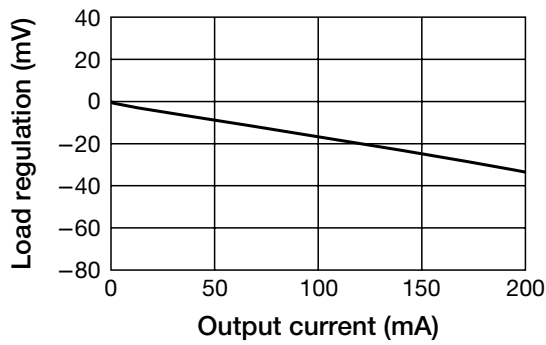

■ Line Regulation Vo1

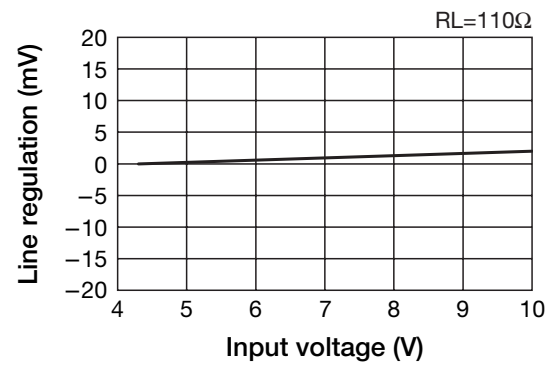

■ Vo3 Output Voltage-Ambient Temperature

