

Low-Saturation 300mA Regulators

Monolithic IC MM159X Series

Outline

This is a 300mA output low-saturation regulator IC with low noise and high ripple rejection ratio. Ceramic capacitors can be used for the output capacitors, and it has an output noise reduction pin and ON/OFF control pin.

Features

- | | |
|-------------------------------------|------------------------------------|
| 1. High precision output voltage | ±2.0% |
| 2. Output current | 300mA |
| 3. Input/output voltage difference | 0.15V typ. (I _o =100mA) |
| 4. High ripple rejection ratio | 70dB typ. |
| 5. Wide operating temperature range | -40~+85°C |
| 6. Output voltage | 1.5~5.0V (0.1V step) |
| 7. Output capacitor | 1μF(ceramic) |

Package

SOP-8D/G

Applications

1. Constant voltage power supply for devices that use batteries
2. Constant voltage power supply for portable communications devices
3. Constant voltage power supply for household electronics products

Block Diagram

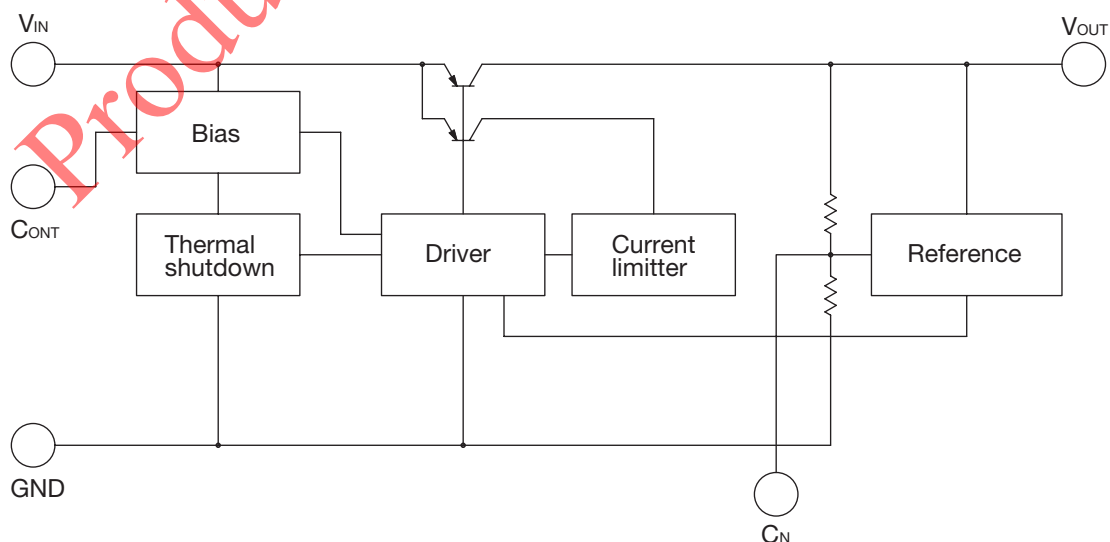

Pin Assignment

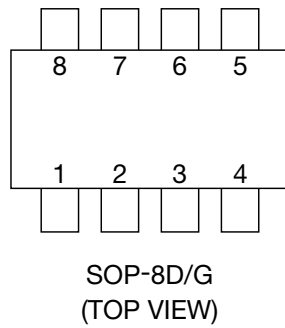

1	V _{OUT}
2	NC
3	GND
4	C _N
5	C _{ONT}
6	NC
7	NC
8	V _{IN}

Pin Description

Pin No.	Pin name	Function	Internal equivalent circuit diagram
1	V _{OUT}	Output pin	
2	NC		
3	GND	Ground pin	
4	C _N	Noise decrease pin	

Pin No.	Pin name	Function	Internal equivalent circuit diagram						
5	CONT	Control pin <table border="1" style="margin-left: 20px;"> <tr> <td>CONT</td> <td>Output</td> </tr> <tr> <td>H</td> <td>ON</td> </tr> <tr> <td>L</td> <td>OFF</td> </tr> </table>	CONT	Output	H	ON	L	OFF	
CONT	Output								
H	ON								
L	OFF								
6	NC								
7	NC								
8	V _{IN}	Input pin							

Absolute Maximum Ratings (Ta=25°C)

Item	Symbol	Ratings	Units
Storage temperature	T _{STG}	-55~+150	°C
Supply voltage	V _{IN}	-0.3~+13	V
Allowable loss	P _d	950 *	mW

Note : * With the double sided PC Board of glass epoxy
(Copper plane 80%, 192X142X1.2mm)

Recommended Operating Conditions

Item	Symbol	Ratings	Units
Operating temperature	T _{OPR}	-40~+85	°C
Output current	I _{OUT}	0~300	mA
Operating voltage	V _{OP}	V _o Typ.+0.5~13	V

Electrical Characteristics 1 (Except where noted otherwise, Ta=25°C, VIN=VO+2V, VCONT=1.6V)

Item	Symbol	Measurement conditions	Min.	Typ.	Max.	Units
No-Load input current	I _{CC}	I _o =0mA		2.2	5	mA
Input current (OFF)	I _{CCOFF}	V _{CONT} =0V		0	1	μA
Output voltage *2	V _{OUT}	I _o =1mA	×0.98		×1.02	V
Dropout voltage *3	V _{IO}	V _{IN} =V _O -0.2V, I _o =100mA		0.15	0.3	V
Line regulation	ΔV ₁	V _{IN} =V _O +1.5~V _O +2.5V, I _o =1mA		10	20	mV
Load regulation	ΔV ₂	I _o =0~300mA		20	120	mV
V _{OUT} temperature coefficient *1	ΔV _{OUT} /ΔT	T _j =-40~+85°C		100		ppm/°C
Ripple rejection *1	RR	f=120Hz V _{RIIPPLE} =1V, I _o =100mA	50	70		dB
Output noise voltage *1	V _N	fBW=20~80kHz, C _N =470pF, I _{OUT} =100mA		75		μVrms
		fBW=20~80kHz, C _N =OPEN, I _{OUT} =100mA		150		
CONT pin input current	I _{CONT}	V _{CONT} =5V	10	20	30	μA
CONT pin high threshold level	V _{CONTH}		1.6		V _{IN} +0.3	V
CONT pin low threshold level	V _{CONTL}		-0.3		0.4	V

Note1 : *1 The parameter is guaranteed by design.

Note2 : *2 Please refer to follow.

Note3 : *3 The parameter is not guaranteed in the model less than V_{OUT}=2V.

Electrical Characteristics 2

Output Voltage

Product name	Test conditions	Output voltage (V)		
		Min.	Typ.	Max.
MM1591J	I _o =1mA	1.764	1.8	1.836
MM1591K		1.862	1.9	1.938
MM1592A		1.960	2.0	2.040
MM1592B		2.058	2.1	2.142
MM1592C		2.156	2.2	2.244
MM1592D		2.254	2.3	2.346
MM1592E		2.352	2.4	2.448
MM1592F		2.450	2.5	2.550
MM1592G		2.548	2.6	2.652
MM1592H		2.646	2.7	2.754
MM1592J		2.744	2.8	2.856
MM1592K		2.842	2.9	2.958
MM1593A		2.940	3.0	3.060
MM1593B		3.038	3.1	3.162
MM1593C		3.136	3.2	3.264
MM1593D		3.234	3.3	3.366
MM1593E		3.332	3.4	3.468
MM1593F		3.430	3.5	3.570
MM1593G		3.528	3.6	3.672
MM1593H		3.626	3.7	3.774
MM1593J	3.724	3.8	3.876	
MM1593K	3.822	3.9	3.978	

Product name	Test conditions	Output voltage (V)		
		Min.	Typ.	Max.
MM1594A	I _o =250mA	3.920	4.0	4.080
MM1594B		4.018	4.1	4.182
MM1594C		4.116	4.2	4.284
MM1594D		4.214	4.3	4.386
MM1594E		4.312	4.4	4.488
MM1594F		4.410	4.5	4.590
MM1594G		4.508	4.6	4.692
MM1594H		4.606	4.7	4.794
MM1594J		4.704	4.8	4.896
MM1594K		4.802	4.9	4.998
MM1595A		4.900	5.0	5.100

Measuring Circuit

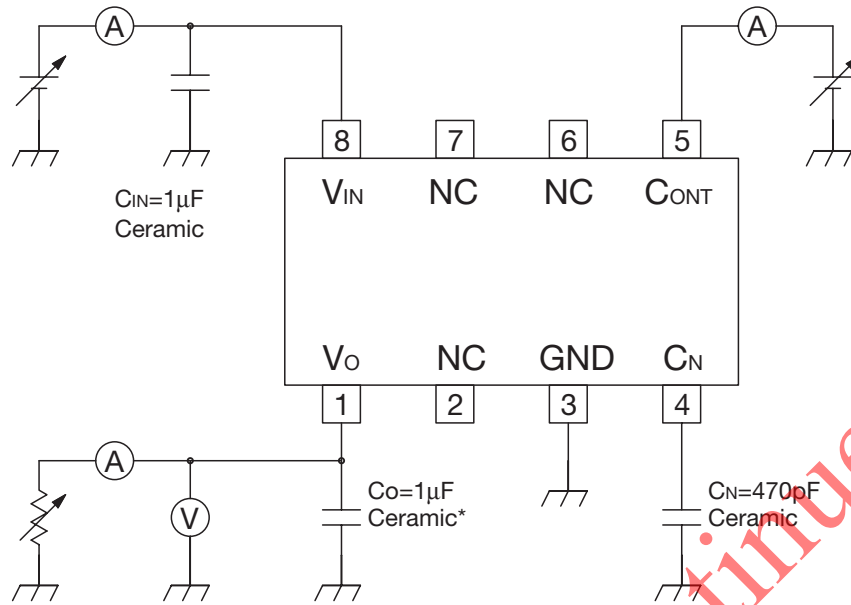

Application Circuit

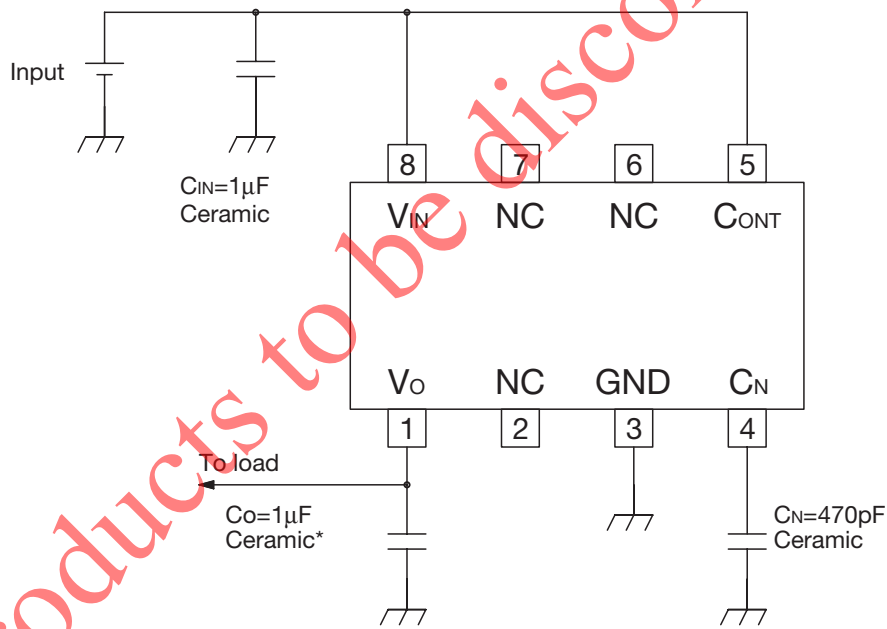

*Temperature Characteristics: B Type (X5R Type)

Note

1. The output capacitor is required between output and GND to prevent oscillation.
2. The ESR of capacitor must be defined in ESR stability area.
It is possible to use a ceramic capacitor without ESR resistance for output.
The ceramic capacitor must be used more than 1.0µF and B type (X5R) temperature characteristics.
3. The wire of Vcc and GND is required to print full ground plane for noise and stability.
4. The input capacitor must be connected a distance of less than 1cm from input pin.
5. The capacitor is connected to Cn must have low leakage current characteristics, because Cn pin is high impedance. The rise time will change depending on the capacitance value.
6. In case the output voltage is above the input voltage, the overcurrent flow by internal parasitic diode from output to input. In such application, the external bypass diode must be connected between output and input pin.

Characteristics (2.5V product Except where noted otherwise, $T_a=25^\circ\text{C}$, $V_{IN}=V_O+2\text{V}$, $V_{CONT}=V_{IN}$, $C_{IN}=1.0\mu\text{F}$, $C_O=1.0\mu\text{F}$)

■ Input Voltage-Output Voltage

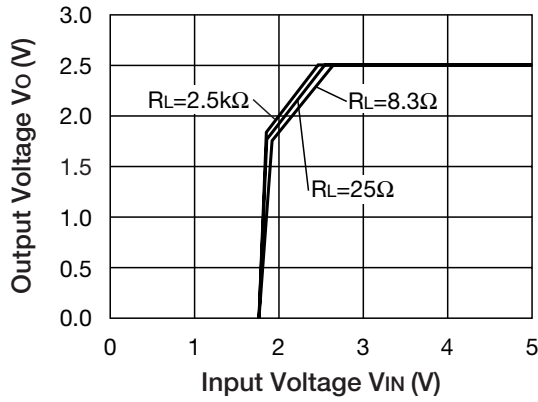

■ No Load Input Current

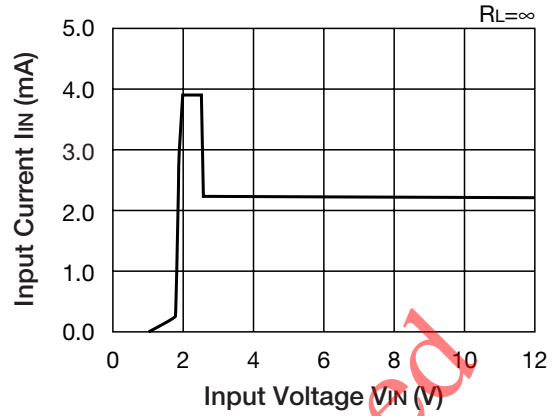

■ Load Regulation

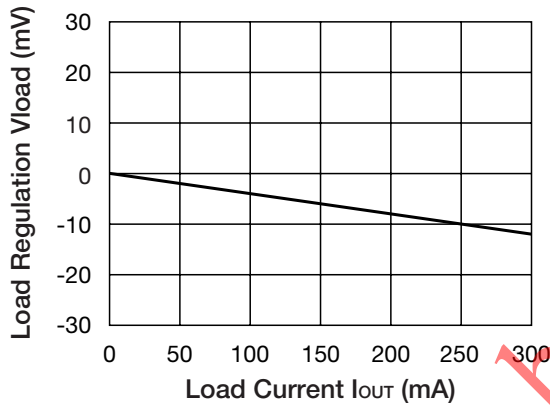

■ Line Regulation

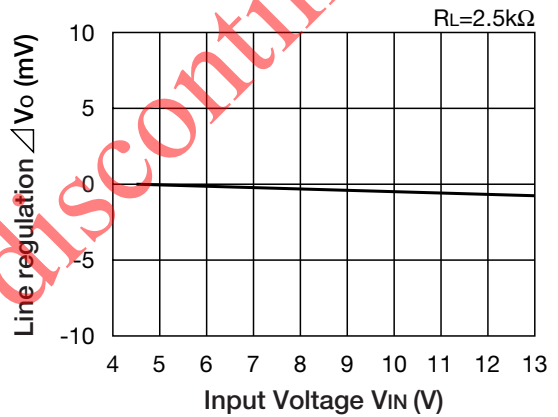

■ Drop Voltage

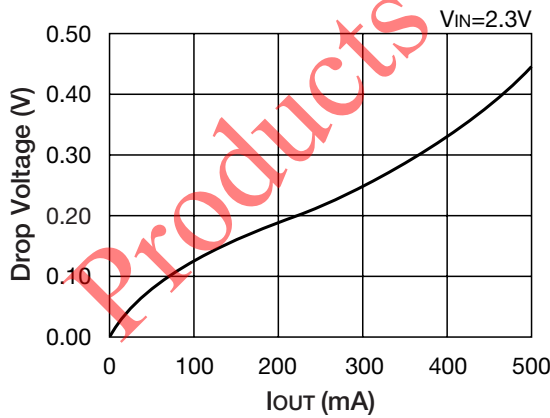

■ Output Voltage ($I_O=0\text{mA}$)

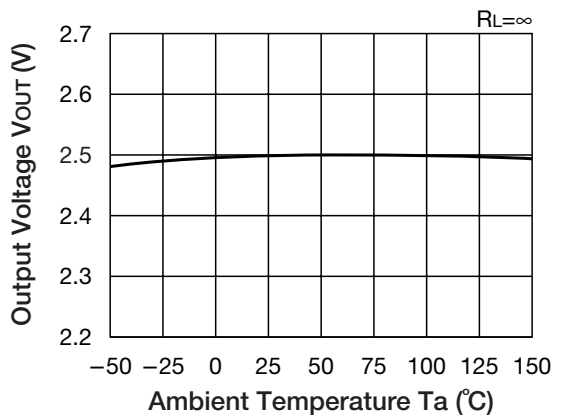

Characteristics (2.5V product Except where noted otherwise, $T_a=25^\circ\text{C}$, $V_{IN}=V_O+2\text{V}$, $V_{\text{CONT}}=V_{IN}$, $C_{IN}=1.0\mu\text{F}$, $C_O=1.0\mu\text{F}$)

Ripple Rejection

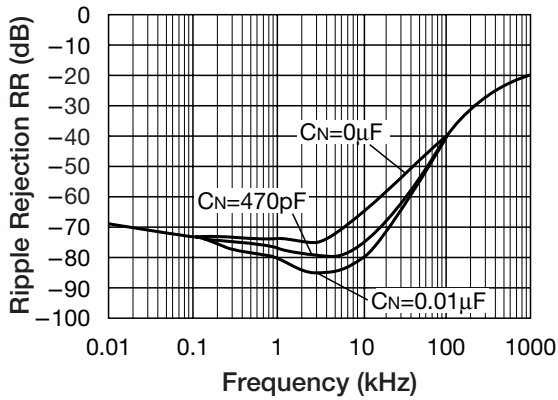

Output Noise

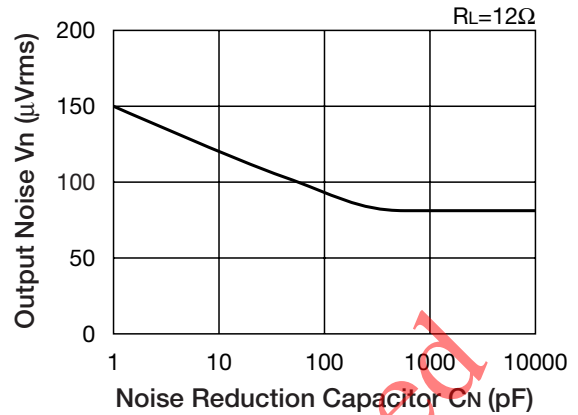

Current Limit Characteristics

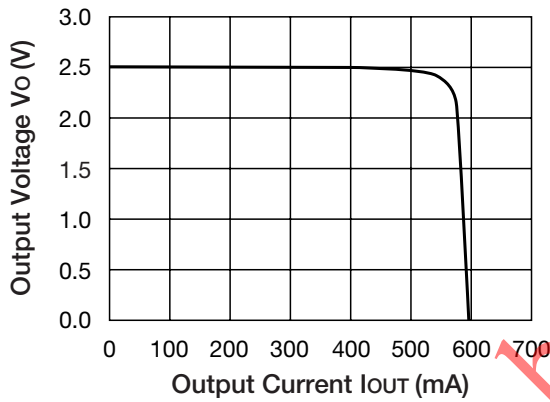

GND Pin Current

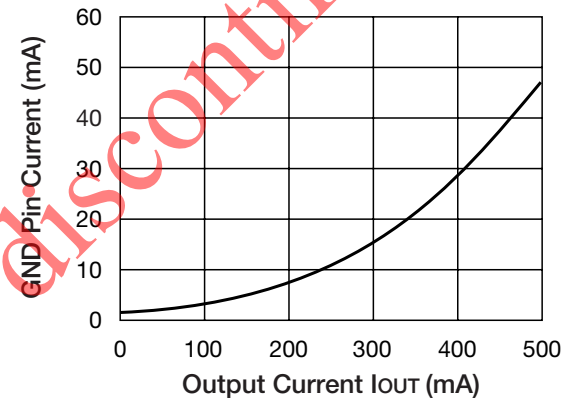

ESR Stability Area

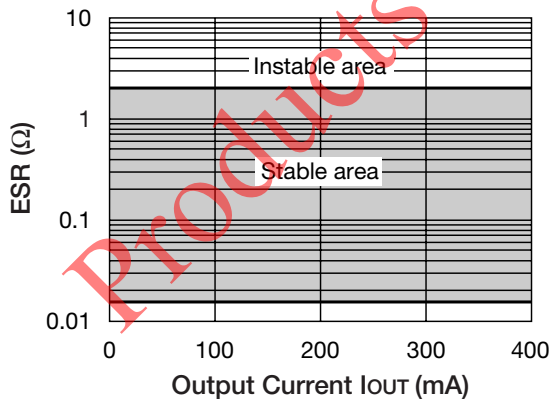

Power Dissipation

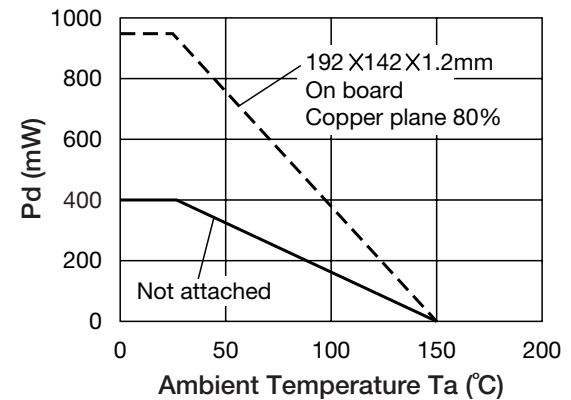

Characteristics (1.8V, 5.0V product Except where noted otherwise, $T_a=25^\circ\text{C}$, $V_{IN}=V_O+2\text{V}$, $V_{CONT}=V_{IN}$, $C_{IN}=1.0\mu\text{F}$, $C_O=1.0\mu\text{F}$)

■ Load Regulation($V_O=1.8\text{V}$)

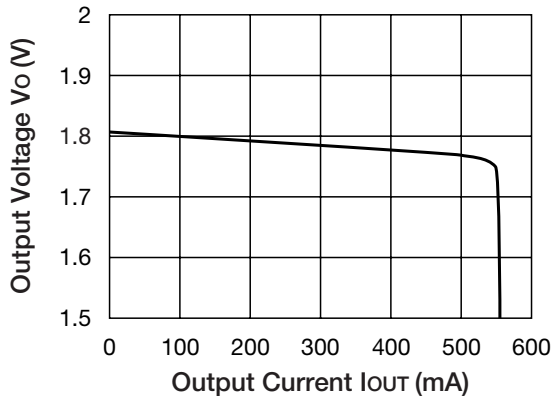

■ Load Regulation($V_O=5.0\text{V}$)

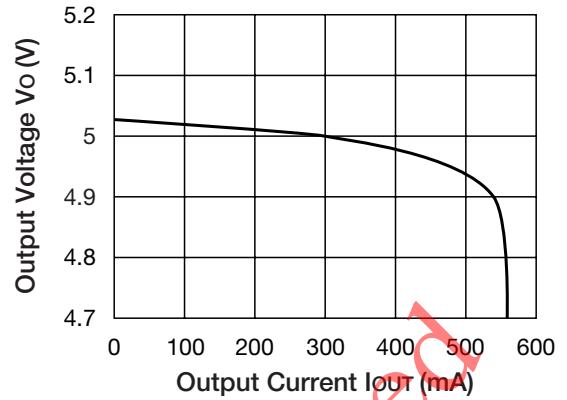

■ Output Voltage($V_O=1.8\text{V}$)

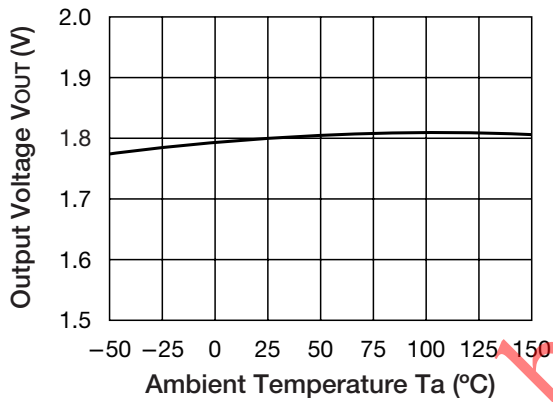

■ Output Voltage($V_O=5.0\text{V}$)

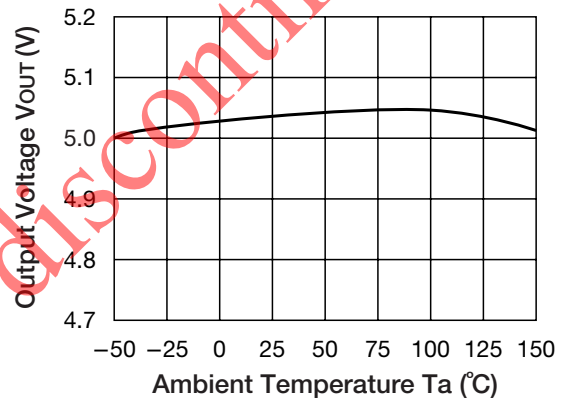

Products to be discontinued