

Q Xpander Processors

Monolithic IC MM1326, 1354, 1369

Outline

These ICs are analog stereo enhancement processors. They use patented Q Xpander technology to create a stereo image with depth in three dimensions from ordinary left and right input channels.

There is no need for any special playback equipment; the enhanced audio effect can be experienced using standard stereo audio equipment.

This IC, produced by Mitsumi, faithfully incorporates algorithms developed by Q Sound Labs, Inc., the world leader in sound enhancement.

Features

1. Sound spreading sensation can be varied at will using an external VR (MM1354, MM1369)
2. Pseudo-stereo effects can be obtained from monaural audio signals (MM1369)
3. Sound spreading sensation can also be varied with a VR for pseudo-stereo from monaural input (MM1369)
4. Q Xpander on/off and pseudo-stereo on/off switching at TTL level
5. Internal filter circuit for few external components (MM1369)
6. No need for input signal encoding or special external equipment, playback possible using ordinary stereo equipment
7. Low-noise design: 55 μ Vrms with Q Xpander on (MM1326)
 60 μ Vrms with Q Xpander on (MM1354)

Package

- SSOP-20A (MM1326AJ)
- SDIP-22A (MM1326AD, MM1354AD, MM1354BD)
- SSOP-24A (MM1354AJ)
- SDIP-24A (MM1369AD, MM1369BD)

Applications

1. Computer sound boards
2. Active speaker systems
3. TV game equipment and other amusement devices
4. TVs, monitors, audio equipment

Line-Up

	MM1326	MM1354	MM1369
Variable sound spreading feature	Fixed	Variable	Variable
Pseudo-stereo function	No	No	Yes (spreading variable)
Operating power supply voltage	4.5~10.0 (V)	4.5~12.0 (V)	8.0~10.0 (V)

[MM1326]

Absolute Maximum Ratings

Item	Symbol	Ratings	Units
Storage temperature	T _{STG}	-40~+125	°C
Operating temperature	T _{OPR}	-20~+75	°C
Power supply voltage	V _{CC} max.	12	V
Input voltage	V _{IN} max.	GND ≤ V _{IN} ≤ V _{CC}	V
Output voltage	I _o max.	10	mA
Allowable loss	P _d	500	mA

Recommended Operating Conditions

Item	Symbol	Ratings	Units
Operating temperature	T _{OPR}	-20~+75	°C
Operating voltage	V _{OP}	4.5~10.0	V

Electrical Characteristics

Item	Measurement conditions	Min.	Typ.	Max.	Units
Consumption current			15	20	mA
Output voltage	*1	2	2.8		V _{rms}
Voltage gain Q Xpander 1	SG1: 1V _{rms} , 1kHz, SG2: no signal	5	6	7	dB
Voltage gain Q Xpander 2	SG1: 1V _{rms} , 1kHz, SG2: no signal	-1	0.5	2	dB
Voltage gain Q Xpander 3	SG1: no signal, SG2: 1V _{rms} , 1kHz	5	6	7	dB
Voltage gain Q Xpander 4	SG1: no signal, SG2: 1V _{rms} , 1kHz	-1	0.5	2	dB
Voltage gain bypass 1	SG1: 1V _{rms} , 1kHz, SG2: no signal	-0.5	0	0.5	dB
Voltage gain bypass 2	SG1: no signal, SG2: 1V _{rms} , 1kHz	-0.5	0	0.5	dB
Input resistance		21	30	39	kΩ
Power supply voltage rejection ratio	V _{CC} =9V+200mV _{rms} , f=1kHz	44	50		dB
Total harmonic distortion ratio Q Xpander	Lch=1V _{rms} , Rch=no signal Lch=no signal, Rch=1V _{rms}		0.3	0.7	%
Total harmonic distortion ratio bypass	Lch=1V _{rms} , Rch=no signal Lch=no signal, Rch=1V _{rms}		0.03	0.3	%
Output noise voltage Q Xpander	L, R channels=no signal, BW=20Hz to 20kHz, A curve		55	100	μV _{rms}
Output noise voltage bypass	L, R channels=no signal, BW=20Hz to 20kHz, A curve		15	32	μV _{rms}
SN ratio Q Xpander	L, R channels=1V _{rms} , 1kHz, BW=20Hz to 20kHz, A curve	80	85		dB
SN ratio bypass	L, R channels=1V _{rms} , 1 kHz, BW=20Hz to 20 kHz, A curve	90	95		dB
L-R channel balance	L, R channels=1V _{rms} , 1kHz, Bypass=0V	-1	0	1	dB
Bypass pin voltage (H)	*2	2.1			V
Bypass pin voltage (L)	*3			0.7	V
Bypass pin voltage (H)	*4			350	μA
Bypass pin voltage (L)	*5	-10			μA

*1: Output voltage amplitude at f=1 kHz such that total output harmonic distortion is 1%

*2: Voltage at which bypass pin (pin 2) is regarded as H (Q Sound mode)

*3: Voltage at which bypass pin (pin 2) is regarded as L (bypass mode)

*4: When V_{byp}=5 V, current flowing into bypass pin (pin 2)

*5: When V_{byp}=0 V, current flowing from bypass pin (pin 2)

[MM1354]

Absolute Maximum Ratings

Item	Ratings	Units
Storage temperature	-40~+125	°C
Operating temperature	-20~+75	°C
Power supply voltage	15	V
Input voltage	$GND \leq V_{IN} \leq V_{CC}$	V
Output voltage	10	mA
Allowable loss	650	mA

Recommended Operating Conditions

Item	Ratings	Units
Operating temperature	-20~+75	°C
Operating voltage	4.5~12.0	V

Electrical Characteristics

Item	Measurement conditions	Min.	Typ.	Max.	Units
Consumption current			16	21	mA
Voltage gain Q Xpander 1	SG1:1Vrms, 1kHz, SG2: no signal	3	4	5	dB
Voltage gain Q Xpander 2	SG1:1Vrms, 1kHz, SG2: no signal	-1	0.5	2	dB
Voltage gain Q Xpander 3	SG1: no signal, SG2: 1Vrms, 1kHz	3	4	5	dB
Voltage gain Q Xpander 4	SG1: no signal, SG2: 1Vrms, 1kHz	-1	0.5	2	dB
Voltage gain bypass 1	SG1:1Vrms, 1kHz, SG2: no signal	-5.6	-5.1	-4.6	dB
Voltage gain bypass 2	SG1: no signal, SG2: 1Vrms, 1kHz	-5.6	-5.1	-4.6	dB
Input resistance		21	30	39	kΩ
Input voltage amplitude (1)	*1	1	1.4		Vrms
Input voltage amplitude (2)	*2	0.5	0.7		Vrms
Total harmonic distortion ratio Q Xpander	Lch=1Vrms, Rch=no signal, Lch=no signal, Rch=1Vrms		0.4	1.0	%
Total harmonic distortion ratio bypass	Lch=1Vrms, Rch=no signal, Lch=no signal, Rch=1Vrms		0.03	0.3	%
Output noise voltage Q Xpander	L, R channels=no signal, BW=20Hz to 20kHz, A curve		60	100	μVrms
Output noise voltage bypass	L, R channels=no signal, BW=20Hz to 20kHz, A curve		15	32	μVrms
L-R channel balance	L, R channels=1Vrms, 1kHz, Bypass=0V	-1	0	1	dB
Bypass pin voltage (H)	*3	2.1			V
Bypass pin voltage (L)	*4			0.7	V
Bypass pin voltage (H)	*5			350	μA
Bypass pin voltage (L)	*6	-10			μA

- *1: Input voltage amplitude at f=1 kHz such that total output harmonic distortion is 1%. However, signals input to SG1 and SG2 are in phase (phase difference 0°).
- *2: Input voltage amplitude at f=1 kHz such that total output harmonic distortion is 1%. However, signals input to SG1 and SG2 are opposite in phase (phase difference 180°).
- *3: Voltage at which bypass pin (pin 22) is regarded as H
- *4: Voltage at which bypass pin (pin 22) is regarded as L
- *5: When Vbyp=5V, current flowing into bypass pin
- *6: When Vbyp=0V, current flowing from bypass pin

[MM1369]

Absolute Maximum Ratings

Item	Ratings	Units
Storage temperature	-40~+125	°C
Operating temperature	-20~+75	°C
Power supply voltage	15	V
Input voltage	$GND \leq V_{IN} \leq V_{CC}$	V
Output voltage	10	mA
Allowable loss	650	mA

Recommended Operating Conditions

Item	Ratings	Units
Operating temperature	-20~+75	°C
Operating voltage	8.0~10.0	V

Electrical Characteristics

Item	Measurement conditions	Min.	Typ.	Max.	Units
Consumption current			20	26	mA
Voltage gain Q Xpander 1	SG1: 1Vrms, 1kHz, SG2: no signal	1.5	3.5	5.5	dB
Voltage gain Q Xpander 2	SG1: 1Vrms, 1kHz, SG2: no signal	-2	0	2	dB
Voltage gain Q Xpander 3	SG1: no signal, SG2: 1Vrms, 1kHz	1.5	3.5	5.5	dB
Voltage gain Q Xpander 4	SG1: no signal, SG2: 1Vrms, 1kHz	-2	0	2	dB
Voltage gain bypass 1	SG1: 1Vrms, 1kHz, SG2: no signal	-7.5	-5.5	-3.5	dB
Voltage gain bypass 2	SG1: no signal, SG2: 1Vrms, 1kHz	-7.5	-5.5	-3.5	dB
Voltage gain pseudo-stereo 1	SG: 1Vrms, 1kHz, SG2: no signal	-9.5	-7.5	-5.5	dB
Voltage gain pseudo-stereo 2	SG1: no signal, SG2: 1Vrms, 1kHz	-7.5	-5.5	-3.5	dB
Output phase (1)	SG1: 1Vrms, 1kHz, SG2: no signal	-75	-60	-45	dB
Output phase (2)	SG1: no signal, SG2: 1Vrms, 1kHz	-140	-125	-110	dB
Input resistance (1)	Vbyp1, 2=0V, f=20Hz	21	30	39	kΩ
Input resistance (2)	Vbyp1, 2=0V, f=1kHz	8	11	14	kΩ
Input resistance (3)	Vbyp1, 2=0V, f=20kHz	5	7	9	kΩ
Input voltage amplitude (1)	*1	1	1.4		Vrms
Input voltage amplitude (2)	*2	0.5	0.7		Vrms
Total harmonic distortion ratio Q Xpander	Lch=1Vrms, Rch=no signal, Lch=no signal, Rch=1Vrms		0.4	1	%
Total harmonic distortion ratio bypass	Lch=1Vrms, Rch=no signal, Lch=no signal, Rch=1Vrms, Vbyp=0V		0.4	0.8	%
Output noise voltage Q Xpander	L, R channels=no signal, BW=20Hz to 20kHz, A curve, Vbyp2=0V		75	150	μVrms
Output noise voltage bypass	L, R channels=no signal, BW=20Hz to 20kHz, A curve, Vbyp1,2=0V		20	40	μVrms
L-R channel balance	L, R channels=1Vrms, 1kHz, Vbyp1,2=0V	-1.5	0	1.5	dB
Bypass pin voltage (H)	*3	2.1			V
Bypass pin voltage (L)	*4			0.7	V
Bypass pin voltage (H)	Vbyp=5V *5			350	μA
Bypass pin voltage (L)	Vbyp=0V *6	-10			μA
Pin 13 offset voltage	Vbyp1=0V *7	-30	0	30	mV
Pin 3 offset voltage	Vbyp1=0V *8	-30	0	30	mV
Pin 4 offset voltage	Vbyp1=0V *9	-30	0	30	mV
Pin 5 offset voltage	Vbyp1=0V *10	-30	0	30	mV

- *1: Input voltage amplitude at f=1 kHz such that total output harmonic distortion is 1%. However, signals input to SG1 and SG2 are in phase (phase difference 0°).
- *2: Input voltage amplitude at f=1 kHz such that total output harmonic distortion is 1%. However, signals input to SG1 and SG2 are opposite in phase (phase difference 180°).
- *3: Voltage at which bypass pin (pin 22) is regarded as H
- *4: Voltage at which bypass pin (pin 22) is regarded as L
- *5: When Vbyp=5V, current flowing into bypass pin
- *6: When Vbyp=0V, current flowing from bypass pin
- *7: Defined as the difference in pin 13 DC output voltages on switching from normal stereo mode to pseudo-stereo mode.
- *8: Defined as the difference in pin 3 DC output voltages on switching from normal stereo mode to pseudo-stereo mode.
- *9: Defined as the difference in pin 4 DC output voltages on switching from normal stereo mode to pseudo-stereo mode.
- *10: Defined as the difference in pin 5 DC output voltages on switching from normal stereo mode to pseudo-stereo mode.

[MM1326]

Block Diagram and Application Circuits

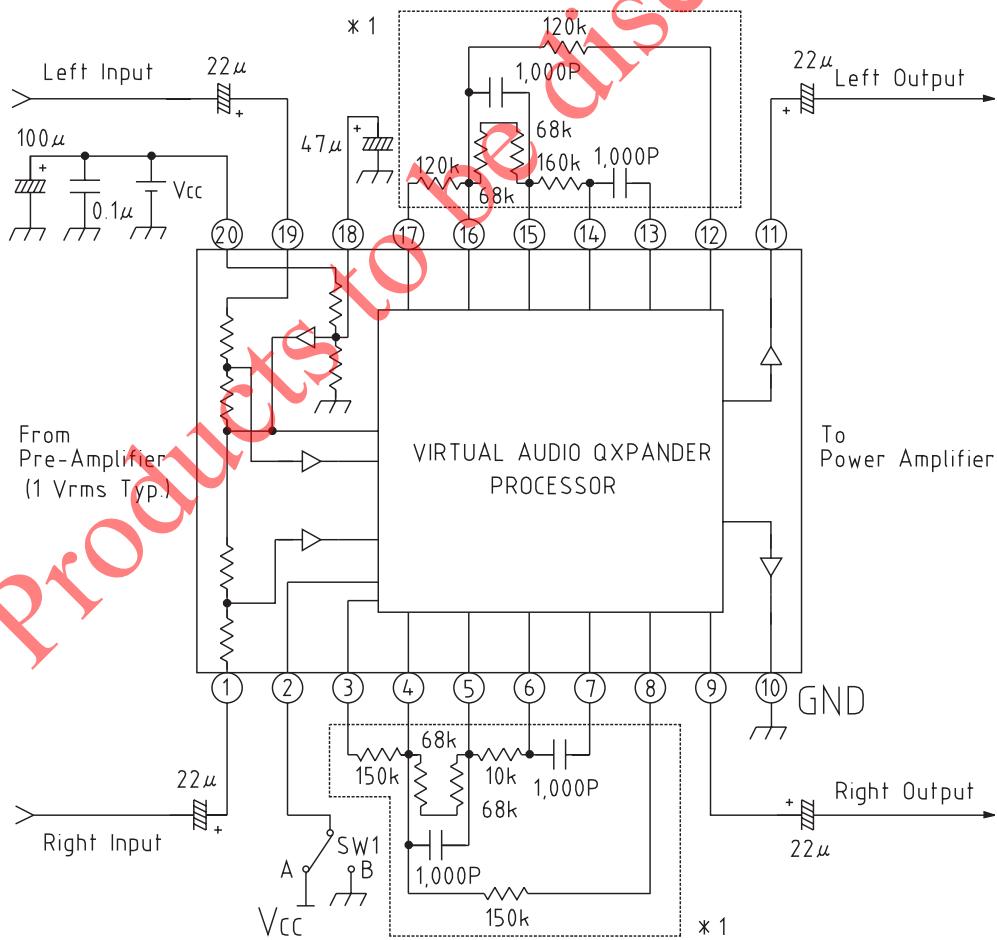
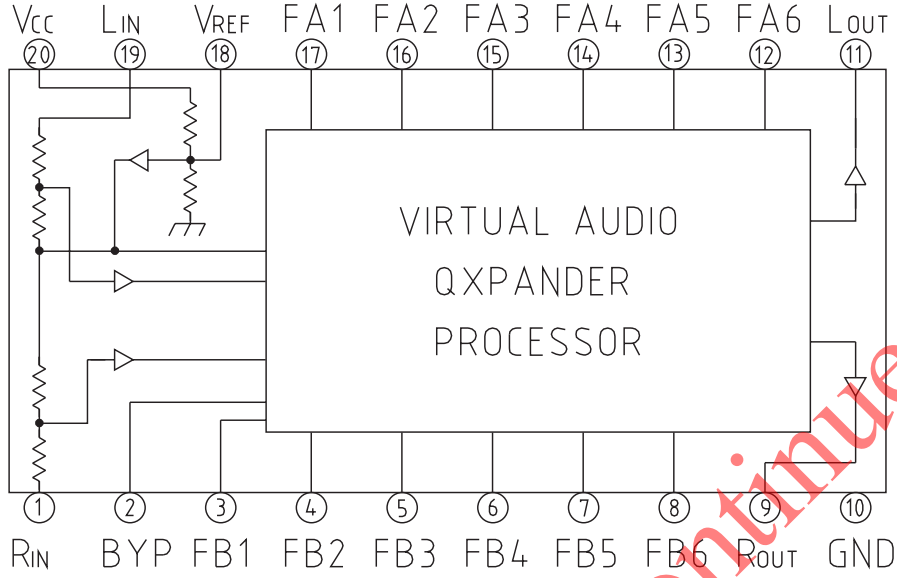

* 1 Resistor tolerance $\pm 1\%$ Capacitor tolerance $\pm 5\%$
 Temperature characteristic $0 \pm 60\text{ppm}/^\circ\text{C}$

[MM1354]

Block Diagram and Application Circuits

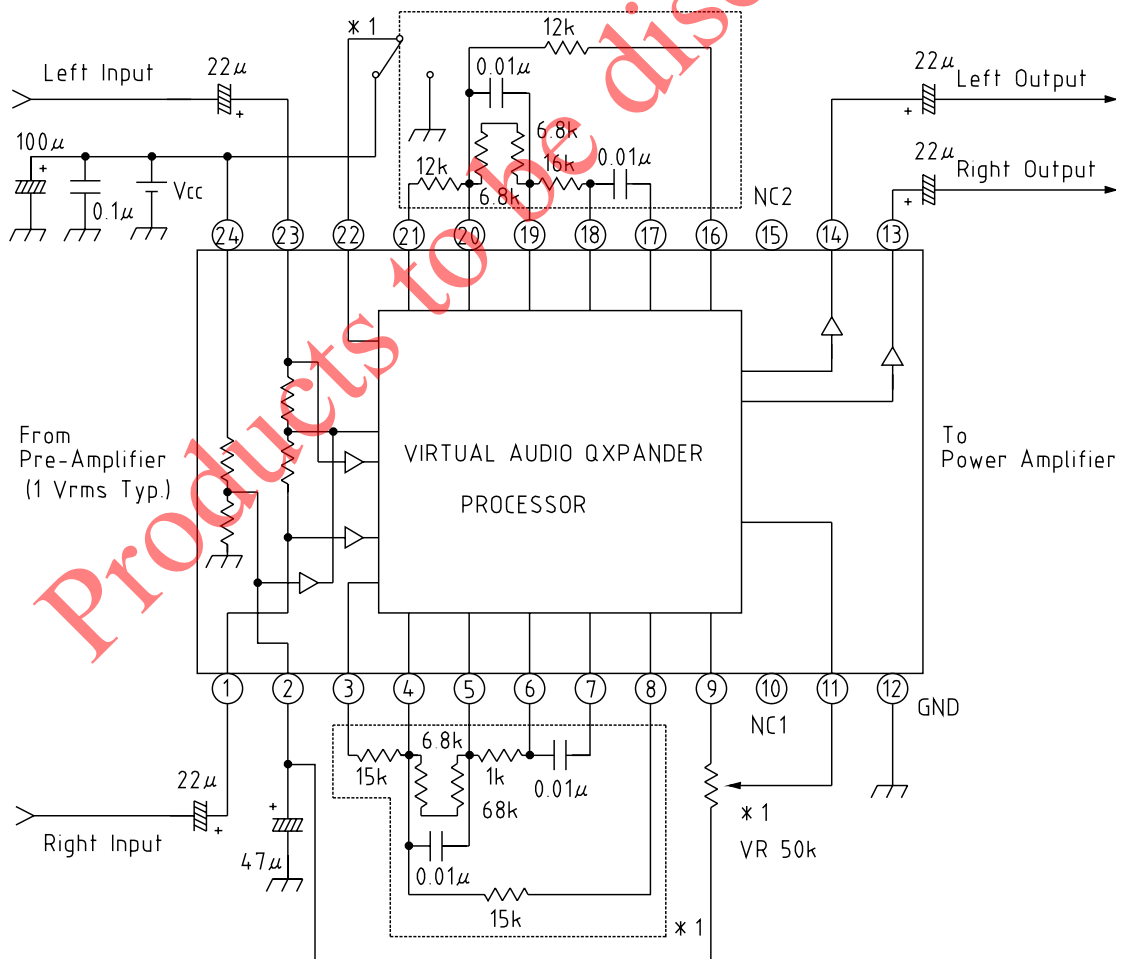
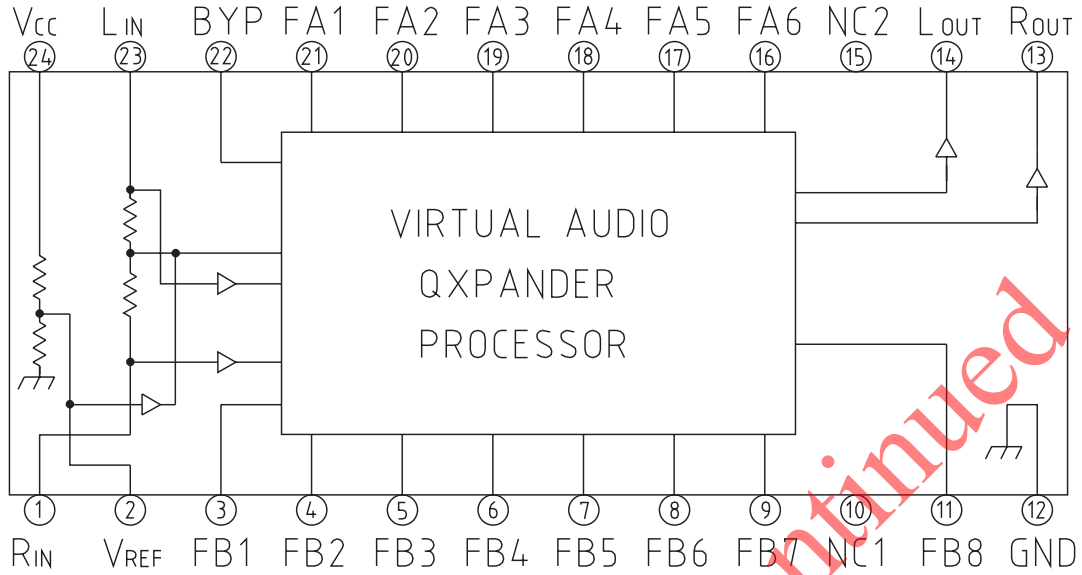

* 1 Resistor tolerance $\pm 1\%$ Capacitor tolerance $\pm 5\%$

Note : * 1 VR can be used to adjust the Q Xpander effect (extent of sound spreading).
 Spreading effect is maximum at 0Ω (pins 9 and 11 shorted);
 normal stereo results at $50 \text{ k}\Omega$ (pins 2 and 11 shorted).

[MM1369]

Block Diagram and Application Circuits

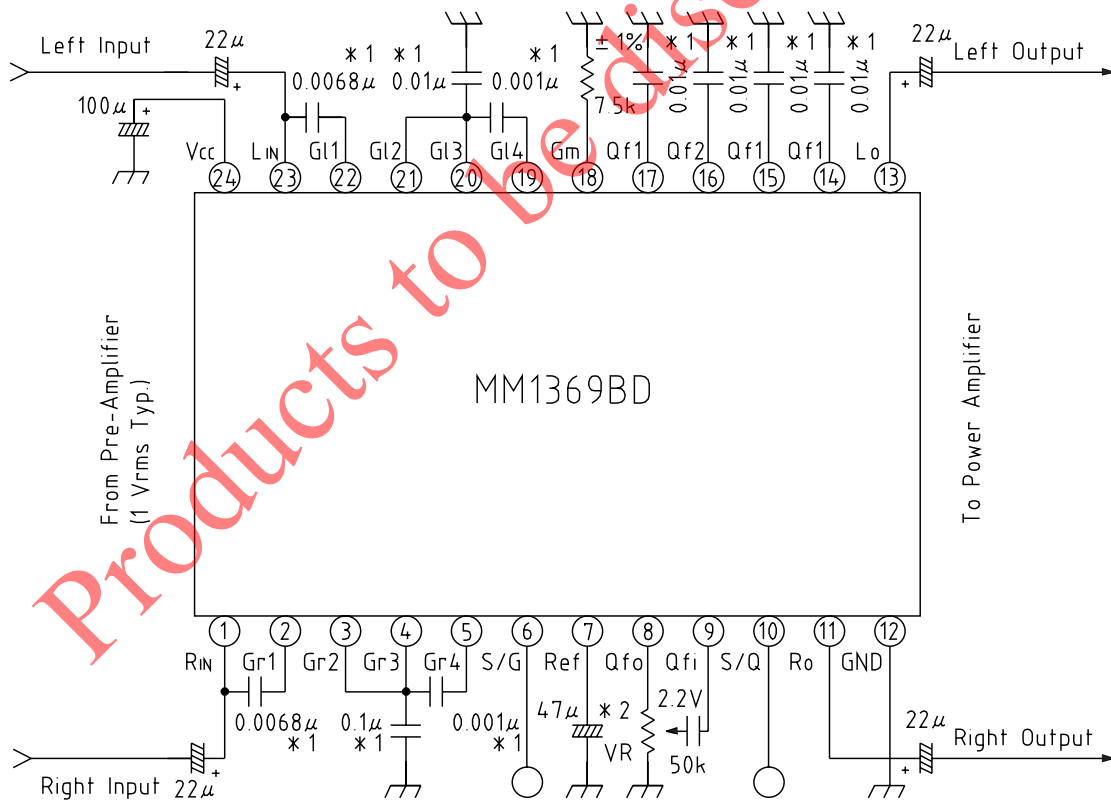
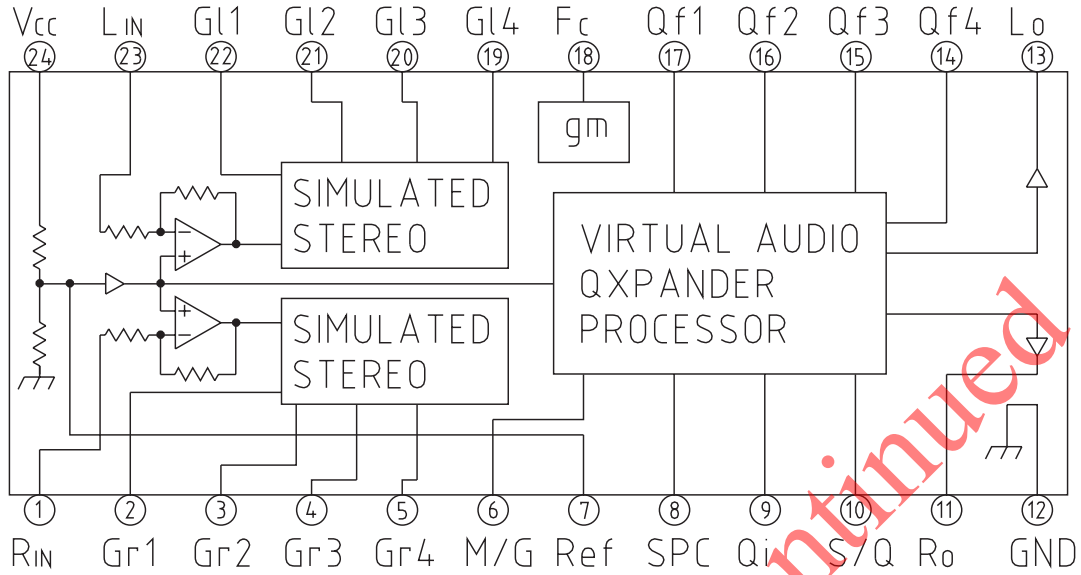

A low-impedance signal source should be used for SG1 and SG2.
 Note 1: *1 A capacitor with a $\pm 5\%$ tolerance is recommended.
 Note 2: *2 VR can be used to adjust the Q Xpander effect (extent of sound spreading).
 Spreading effect is maximum at 50 k Ω ;
 normal stereo results at 0 Ω ;

Characteristics

■ [MM1326]

■ LIN-Rout (RIN-Lout) Frequency characteristic
LIN-Rout (RIN-Lout) Voltage gain—Frequency

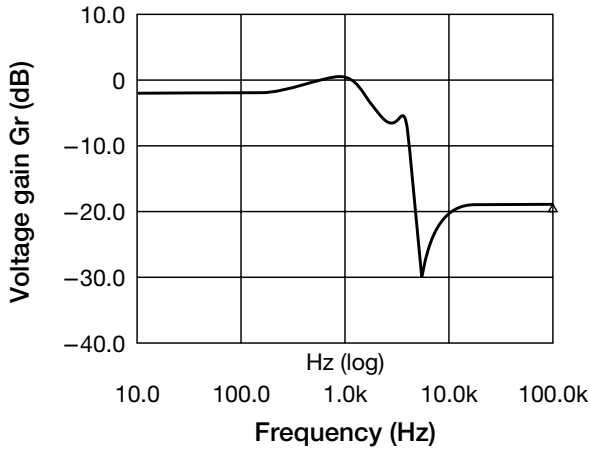

■ LIN-Lout (RIN-Rout) Frequency characteristic
LIN-Lout (RIN-Rout) Voltage gain—Frequency

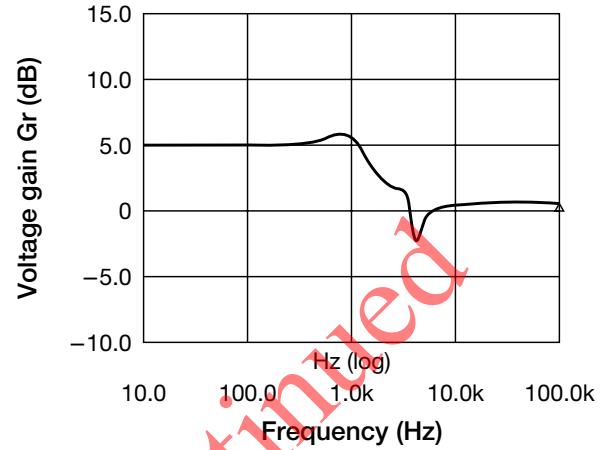

■ [MM1354]

■ LIN-Rout (RIN-Lout) Frequency characteristic
LIN-Rout (RIN-Lout) Voltage gain—Frequency

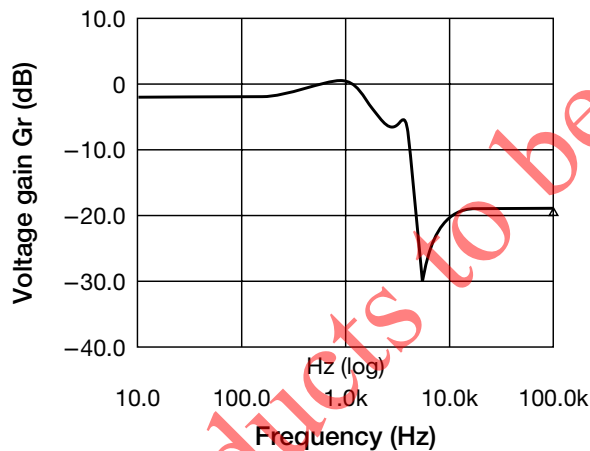

■ LIN-Lout (RIN-Rout) Frequency characteristic
LIN-Lout (RIN-Rout) Voltage gain—Frequency

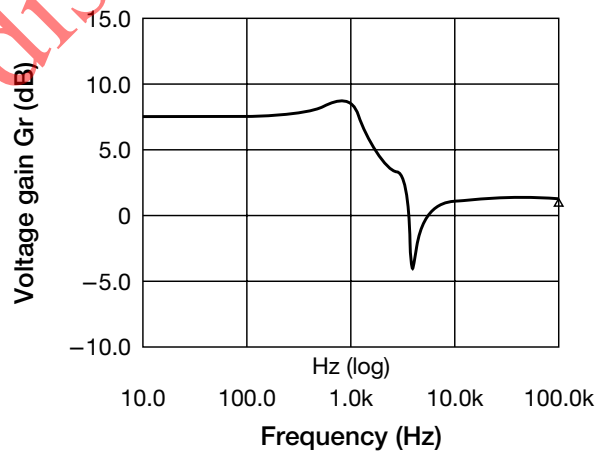

■ [MM1369]

■ LIN-Rout (RIN-Lout) Frequency characteristic
LIN-Rout (RIN-Lout) Voltage gain—Frequency

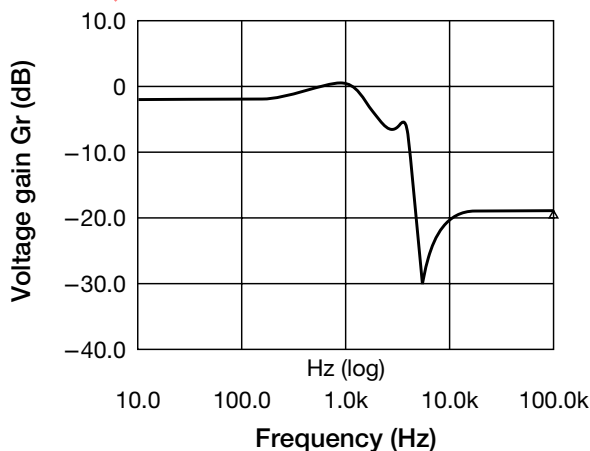

■ LIN-Lout (RIN-Rout) Frequency characteristic
LIN-Lout (RIN-Rout) Voltage gain—Frequency

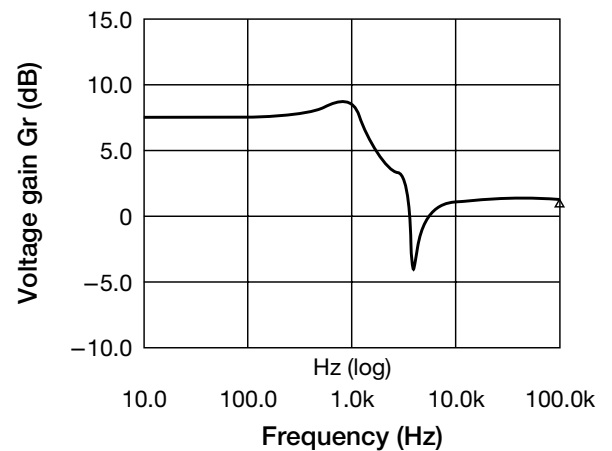

Ideal Settings for Q Sound

1. Speaker heights should be equal

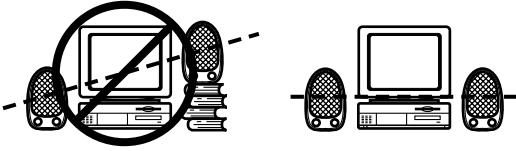

2. Speaker faces should be aligned

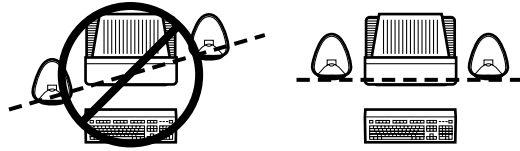

3. Speaker orientations should be the same

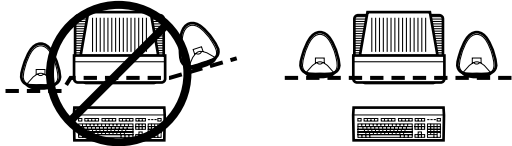

4. Right and left channel volumes should be equal

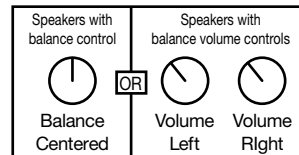

5. Listening is best midway between the speakers

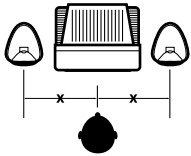

Products to be discontinued