

# IC for System Reset (with built-in watchdog timer) Monolithic IC MM1075

## Outline

This IC functions in a variety of CPU systems and other logic systems to generate a reset signal and reset the system accurately when the power is turned on or interrupted.

It includes a watchdog timer which allows diagnosis of the system operation, so that it prevents system runaway by intermittently generating a reset pulse when system misoperation occurs.

## Features

1. Built-in watchdog timer
2. Low minimum operating voltage  $V_{CC}=0.8V$  typ.
3. Positive and negative logic reset outputs can be extracted
4. Accurate detection of drop in supply voltage
5. Detection voltage with hysteresis
6. Few external components one capacitor
7. Timer monitoring time can be varied by using an external resistor.

## Packages

- DIP-8A (MM1075XD)
- SOP-8A (MM1075XF)

## Application

Microcomputer system monitoring, etc.

## Absolute Maximum Ratings (Ta=25°C)

Item	Symbol	Rating	Units
Storage temperature	T <sub>STG</sub>	-40~+125	°C
Operating temperature	T <sub>OPR</sub>	-20~+70	°C
Power supply voltage	V <sub>CC</sub> max.	-0.3~+10	V
Voltage applied to VS & CK pins	V <sub>VS</sub> & V <sub>CK</sub>	-0.3~+10	V
Voltage applied to RESET, RESET pin	V <sub>OH</sub>	-0.3~+10	V
Allowable loss	P <sub>d</sub>	400	mW

**Electrical Characteristics (DC)** (Except where noted otherwise,  $T_a=25^{\circ}\text{C}$ ,  $V_{CC}=5\text{V}$ )

Item	Symbol	Measurement circuit	Measurement conditions	Min.	Typ.	Max.	Units
Consumption current	$I_{CC}$	1	During watchdog timer operation		0.7	1.0	mA
Detection voltage	$V_{SL}$	1	$V_S=OPEN, V_{CC}$	4.05	4.20	4.35	V
	$V_{SH}$	1	$V_S=OPEN, V_{CC}$	4.15	4.30	4.45	
Detection voltage temperature coefficient	$V_S/\Delta T$	1			$\pm 0.01$		%/ $^{\circ}\text{C}$
Hysteresis voltage	$V_{HYS}$	1	$V_{SH}-V_{SL}, V_{CC}$	50	100	150	mV
CK input threshold	$V_{TH}$	1		0.8	1.2	2	V
CK input current	$I_{IH}$	1	$V_{CK}=5\text{V}$		0	1	$\mu\text{A}$
	$I_{IL}$	1	$V_{CK}=0\text{V}$	-20	-10	-3	
Output voltage (High)	$V_{OH1}$	1	$I_{\overline{RESET}}=-5\mu\text{A}, V_S=OPEN$	4.5	4.8		V
	$V_{OH2}$	1	$I_{\overline{RESET}}=-5\mu\text{A}, V_S=0\text{V}$	4.5	4.8		
Output voltage (Low)	$V_{OL1}$	1	$I_{\overline{RESET}}=3\text{mA}, V_S=0\text{V}$		0.2	0.4	V
	$V_{OL2}$	1	$I_{\overline{RESET}}=10\text{mA}, V_S=0\text{V}$		0.3	0.5	
	$V_{OL3}$	1	$I_{\overline{RESET}}=0.5\text{mA}, V_S=OPEN$		0.2	0.4	
	$V_{OL4}$	1	$I_{\overline{RESET}}=1\text{mA}, V_S=OPEN$		0.3	0.5	
Output sink current	$I_{OL1}$	1	$V_{\overline{RESET}}=1.0\text{V}, V_S=0\text{V}$	10	16		mA
	$I_{OL2}$	1	$V_{\overline{RESET}}=1.0\text{V}, V_S=OPEN$	1	2		
$C_T$ charge current *1	$I_{CT1}$	1	$V_{TC}=1.0\text{V}, R_{CT}=OPEN$ during watchdog timer operation	-0.8	-1.2	-2.4	$\mu\text{A}$
	$I_{CT2}$	1	$V_{TV}=1.0\text{V}$ during power ON reset operation	-0.8	-1.2	-2.4	$\mu\text{A}$
Minimum operating power supply voltage to ensure $\overline{RESET}$	$V_{CCL1}$	1	$V_{\overline{RESET}}=0.4\text{V}$ $I_{\overline{RESET}}=0.2\text{mA}$		0.8	1.0	V
Minimum operating power supply voltage to ensure $\overline{RESET}$	$V_{CCL2}$	1	$V_{\overline{RESET}}=V_{CC}-0.1\text{V}$ $R_{L2}$ (between Pin 2 and GND)		0.8	1.0	V

**Electrical Characteristics (AC)** (Except where noted otherwise, Ta=25°C, Vcc=5V)  
(Except where noted otherwise, resistance unit is Ω)

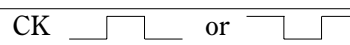
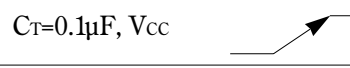
Item	Symbol	Measurement circuit	Measurement conditions	Min.	Typ.	Max.	Units
V <sub>CC</sub> input pulse width	T <sub>P1</sub>	2	V <sub>CC</sub> 	8			μs
CK input pulse width	T <sub>CKW</sub>	2	CK 	3			μs
CK input cycle	T <sub>CK</sub>	2		20			μs
Watchdog timer monitoring time *2	T <sub>WD</sub>	2	C <sub>T</sub> =0.1μF R <sub>CT</sub> =OPEN	50	100	150	ms
Reset time for watchdog timer *3	T <sub>WR</sub>	2	C <sub>T</sub> =0.1μF	1	2	3	ms
Reset hold time for power supply rise *4	T <sub>PR</sub>	2	C <sub>T</sub> =0.1μF, V <sub>CC</sub> 	50	100	150	ms
Output delay time from V <sub>CC</sub> *5	T <sub>PD1</sub>	2	RESET pin R <sub>L1</sub> =2.2k, C <sub>L1</sub> =100pF		2	10	μs
	T <sub>PD2</sub>	2	RESET pin R <sub>L1</sub> =10k, C <sub>L1</sub> =20pF		3	10	
Output rise time *6	t <sub>r1</sub>	2	RESET pin R <sub>L1</sub> =2.2k, C <sub>L1</sub> =100pF		1.0	1.5	μs
	t <sub>r2</sub>	2	RESET pin R <sub>L2</sub> =10k, C <sub>L2</sub> =20pF		1.0	1.5	μs
Output fall time *6	t <sub>f1</sub>	2	RESET pin R <sub>L1</sub> =2.2k, C <sub>L1</sub> =100pF		0.1	0.5	μs
	t <sub>f2</sub>	2	RESET pin R <sub>L2</sub> =10k, C <sub>L2</sub> =20pF		0.5	1.0	μs

Notes:

- \*1 I<sub>CT1</sub> changes according to R<sub>CT</sub> pin (Pin 6) pull up resistance.
- \*2 Monitoring time is the time from the last pulse (negative edge) of the timer clear clock pulse until reset pulse output. In other words, reset output is output if a clock pulse is not input during this time. Also, monitoring time can be varied by pulling up the R<sub>CT</sub> pin to V<sub>CC</sub> with a resistor (R<sub>CT</sub>). Monitoring time adjustments are shown in Graph 1.
- \*3 Reset time means reset pulse width. However, this does not apply to power ON reset.
- \*4 Reset hold time is the time from when V<sub>CC</sub> exceeds detection voltage (V<sub>SH</sub>) during power ON reset until reset release (RESET output high, RESET output low).
- \*5 Output delay time is the time from when power supply voltage drops below detection voltage (V<sub>SI</sub>) until reset (RESET output low, RESET output high).
- \*6 Voltage range when measuring output rise and fall is 10~90%.
- \*7 Watchdog timer monitoring time (T<sub>WD</sub>), watchdog timer reset time (T<sub>WR</sub>) and reset hold time (T<sub>PR</sub>) during power supply rise can be changed by varying C<sub>T</sub> capacitance. The times are expressed by the following formulae. The recommended range for C<sub>T</sub> is 0.001~10μF.

$$T_{PR} \text{ (ms)} \approx 1000 \times C_T \text{ (}\mu\text{F)}$$

$$T_{WD} \text{ (ms)} \approx 1000 \times C_T \text{ (}\mu\text{F)}$$

$$T_{WR} \text{ (ms)} \approx 20 \times C_T \text{ (}\mu\text{F)}$$

Example : When C<sub>T</sub>=0.1μF (R<sub>CT</sub> pin OPEN)

$$T_{PR} \approx 100\text{ms}$$

$$T_{WD} \approx 100\text{ms}$$

$$T_{WR} \approx 2\text{ms}$$

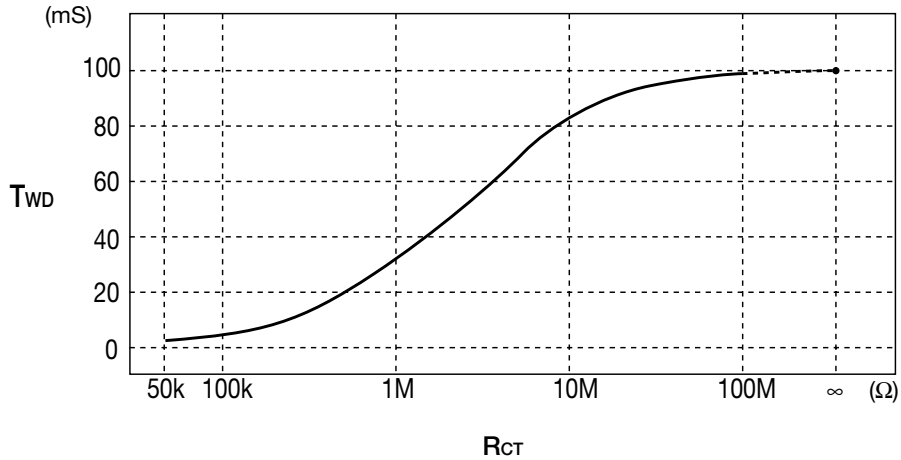

Graph 1 RCT & Monitoring Time

Note : The above graph shows data for when  $C_T=0.1\mu F$ .

$T_{WD}$  is proportionate to  $C_T$ . Refer to the calculation formula for  $T_{WD}$  above.

Block Diagram

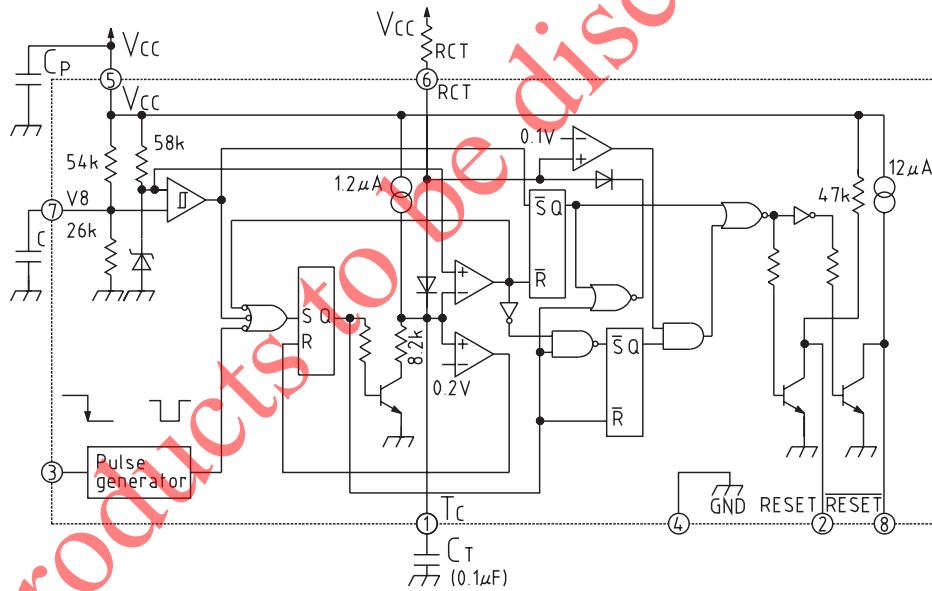

Note 1 :  $C_P=0.1\mu F$  approx.

Note 2 :  $C \approx 1000pF$

Note 3 : The watchdog timer can be stopped by connecting the RCT pin to GND. (Then it functions as a voltage detection circuit.)

Note 4 :  $T_{PR}$  and  $T_{WD}$  can be varied by pulling up the RCT pin to  $V_{CC}$  with a resistor. The recommended range for RCT is  $100k\Omega \sim R_{CT}$  pin OPEN.

Timing Chart

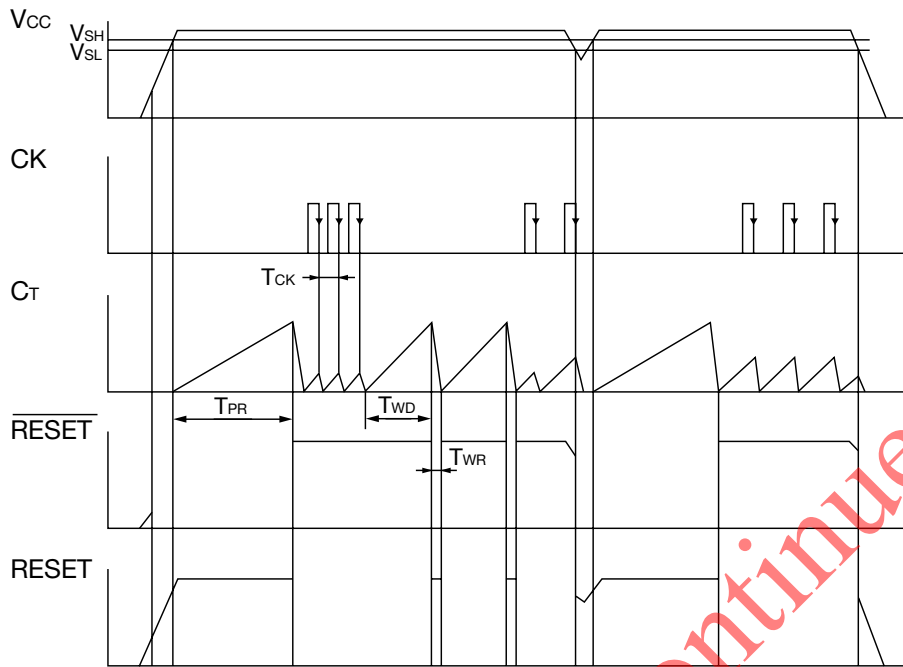

Pin Assignment

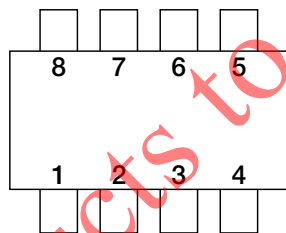

1	TC
2	RESET
3	CK
4	GND
5	V <sub>CC</sub>
6	RCT
7	V <sub>S</sub>
8	RESET

Pin Description

Pin No.	Pin Name	Function
1	TC	T <sub>WD</sub> , T <sub>WR</sub> , T <sub>PR</sub> variable pins. (T <sub>WD</sub> , T <sub>WR</sub> and T <sub>PR</sub> times are determined by the external capacitor.)
2	RESET	Reset output pin (High output)
3	CK	Clock input pin (inputs clock from logic system)
4	GND	GND pin
5	V <sub>CC</sub>	4.2V detection voltage
6	RCT	Watchdog timer stop pin Operation modes : Operation → OPEN, Stop → connect to GND
7	V <sub>S</sub>	Detection voltage variable pin Adjustment modes : Lower → pull up resistance, Raise → pull down
8	RESET	Reset output pin (Low output)

Measuring Circuits

Measuring Circuit 1

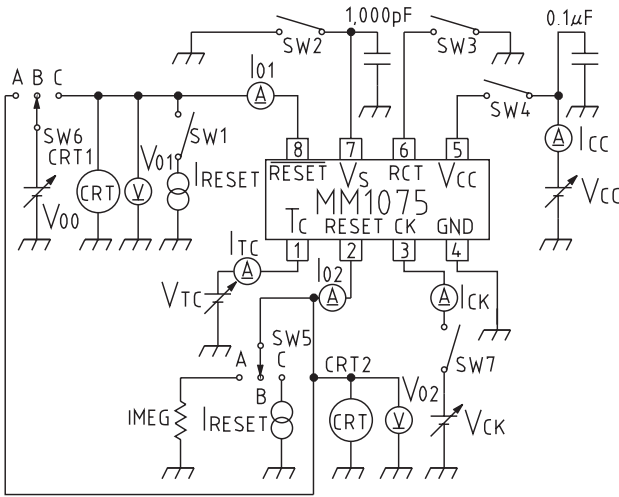

Measuring Circuit 2

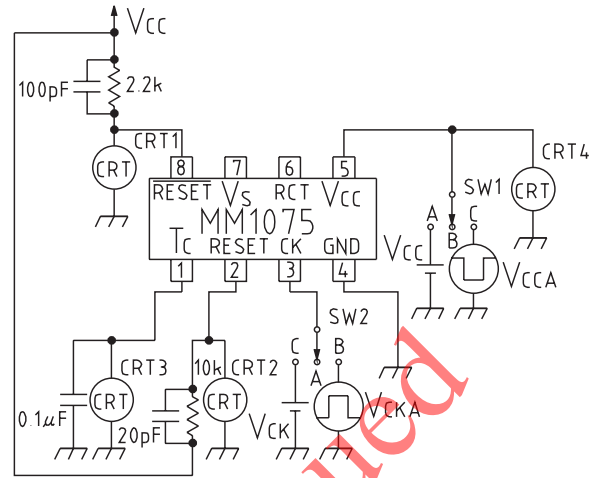

Measuring Circuit 2-1 SW & Power Supply Table

Item	Symbol	SW1	SW2	SW3	SW4	SW5	SW6	SW7	V <sub>cc</sub>	V <sub>ck</sub>	V <sub>ct</sub>	I <sub>RESET</sub>	I <sub>RESET</sub>	VM, IM	Notes
Consumption current	I <sub>cc</sub>	OFF	OFF	OFF	ON	B	B	ON	5V	5V	0V	-	-	I <sub>cc</sub>	
Detection voltage	V <sub>sl</sub>	OFF	OFF	ON	ON	B	B	ON	5V→4V	3V	3V	-	-	Vo1, CRT1	
	V <sub>sh</sub>	OFF	OFF	ON	ON	B	B	ON	4V→5V	3V	3V	-	-	Vo1, CRT1	
CK input threshold	V <sub>th</sub>	OFF	OFF	OFF	ON	B	B	ON	5V	0V→3V	1V	-	-	I <sub>ck</sub>	
CK input current	I <sub>ih</sub>	OFF	OFF	OFF	ON	B	B	ON	5V	5V	0V	-	-	I <sub>ck</sub>	
	I <sub>il</sub>	OFF	OFF	OFF	ON	B	B	ON	5V	0V	0V	-	-	I <sub>ck</sub>	
Output voltage (High)	V <sub>oh1</sub>	ON	OFF	ON	ON	B	B	ON	5V	5V	3V	-5μA	-	Vo1	
	V <sub>oh2</sub>	OFF	ON	ON	ON	C	B	ON	5V	5V	3V	-	-5μA	Vo2	
Output voltage (Low)	V <sub>ol1</sub>	ON	ON	ON	ON	B	B	ON	5V	5V	3V	3mA	-	Vo1	
	V <sub>ol2</sub>	ON	ON	ON	ON	B	B	ON	5V	5V	3V	10mA	-	Vo1	
	V <sub>ol3</sub>	OFF	OFF	ON	ON	C	B	ON	5V	5V	3V	-	0.5mA	Vo2	
	V <sub>ol4</sub>	OFF	OFF	ON	ON	C	B	ON	5V	5V	3V	-	1mA	Vo2	
Output sink current	I <sub>ol1</sub>	OFF	ON	ON	ON	B	C	ON	5V	5V	3V	-	-	I <sub>o1</sub>	V <sub>oo</sub> =1V
	I <sub>ol2</sub>	OFF	OFF	ON	ON	B	A	ON	5V	5V	3V	-	-	I <sub>o2</sub>	V <sub>oo</sub> =1V
C <sub>T</sub> charge current 1	I <sub>rc1</sub>	OFF	OFF	OFF	ON	B	B	OFF	5V	-	1V	-	-	I <sub>rc</sub>	
C <sub>T</sub> charge current 2	I <sub>rc2</sub>	OFF	OFF	ON	ON	B	B	OFF	5V	-	1V	-	-	I <sub>rc</sub>	
Minimum operating power supply voltage to ensure RESET	V <sub>cc1</sub>	ON	OFF	ON	ON	B	B	ON	0V→2V	0V	0V	-	-	Vo1, V <sub>cc</sub>	
Minimum operating power supply voltage to ensure RESET	V <sub>cc2</sub>	OFF	ON	ON	ON	A	B	ON	0V→2V	0V	0V	-	-	Vo2, V <sub>cc</sub>	

**Measuring Circuit 2-2** SW & Power Supply Table

Item	Symbol	SW1	SW2	V <sub>CCA</sub>	V <sub>CC</sub>	V <sub>CKA</sub>	V <sub>CK</sub>	CRT	Notes
Vcc input pulse width	T <sub>PI</sub>	C	B	5V 4V	-	1.4V 0V	-	CRT1, 2, 3	T1=8μs
CK input pulse width	T <sub>CKW</sub>	A	B	-	5V	1.4V 0V	-	CRT1, 2, 3	T2=3μs
CK input cycle	T <sub>CK</sub>	A	B	-	5V	1.4V 0V	-	CRT1, 2, 3	T3=20μs
Watchdog timer monitoring time	T <sub>WD</sub>	A	A	-	5V	-	5V	CRT1, 2, 3	
Reset time for watchdog timer	T <sub>WR</sub>	A	A	-	5V	-	5V	CRT1, 2, 3	
Reset hold time for power supply rise	T <sub>PR</sub>	B→A	A	-	5V	-	5V	CRT1, 2, 3	
Output delay time from Vcc	T <sub>PD1</sub>	C	A	5V 0V	-	-	0V	CRT1, 3	
	T <sub>PD2</sub>	C	A	5V 0V	-	-	0V	CRT2, 3	
Output rise time	T <sub>r1</sub>	A	A	-	5V	-	5V	CRT1	
	T <sub>r2</sub>	A	A	-	5V	-	5V	CRT2	
Output fall time	T <sub>f1</sub>	A	A	-	5V	-	5V	CRT1	
	T <sub>f2</sub>	A	A	-	5V	-	5V	CRT2	

**Detection Voltage Adjustment 1** (lowering detection voltage)

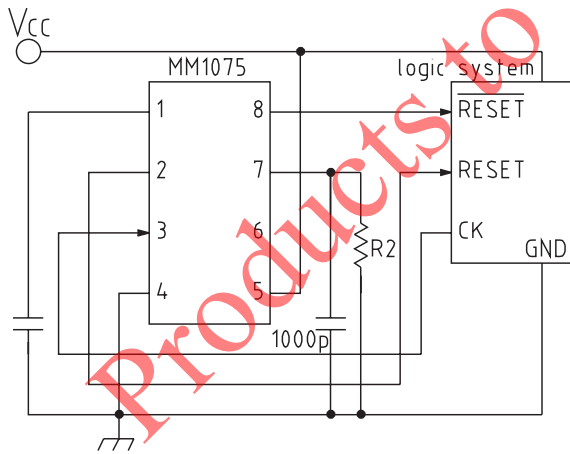

Graph 1. Detection voltage change using MM1075 external resistor

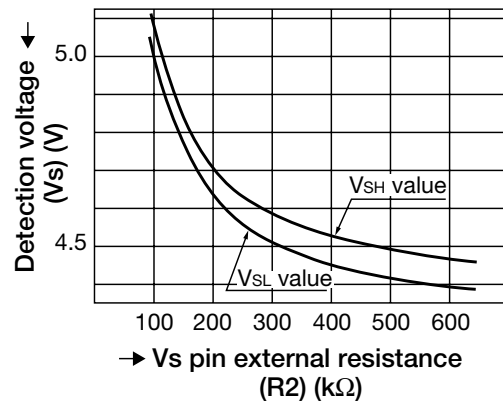

Detection voltage can be changed by connecting resistor R2 externally to MM1075 Vs pin. Determine R2 according to graph 1 when changing Vs.

**Detection Voltage Adjustment 2** (raising detection voltage)

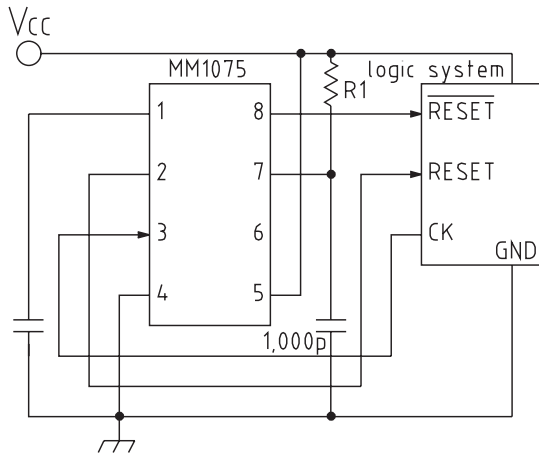

Detection voltage can be changed by connecting resistor R1 externally to MM1075 Vs pin. Determine R1 according to graph 2 when changing Vs.

Graph 2. Detection voltage change using MM1075 external resistor

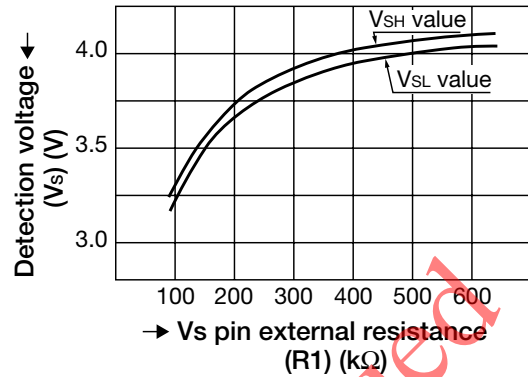

**Characteristics**

■ Power supply current-Power supply voltage

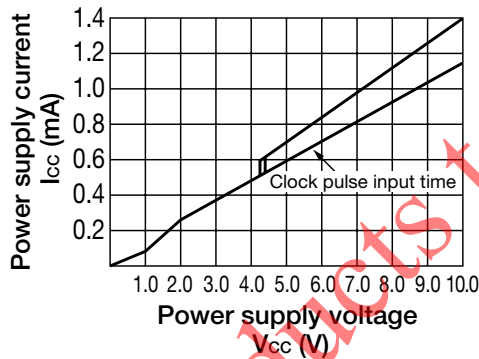

■ Output voltage-Power supply voltage (RESET pin)

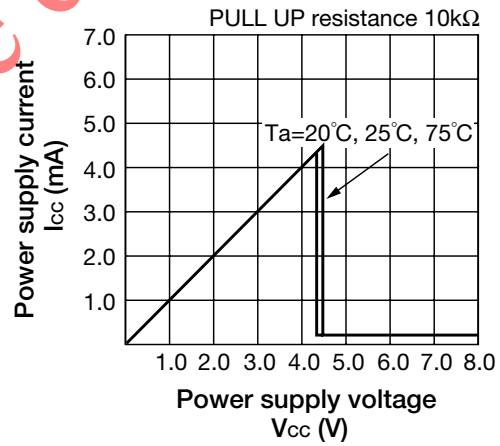

■ Output voltage-Power supply voltage (RESET pin)

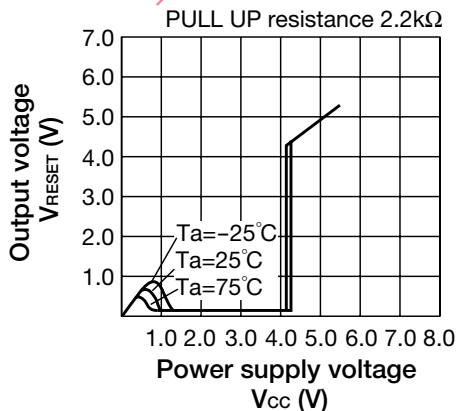

■ Detection voltage (V<sub>SL</sub>, V<sub>SH</sub>) temperature (RESET, RESET pins)

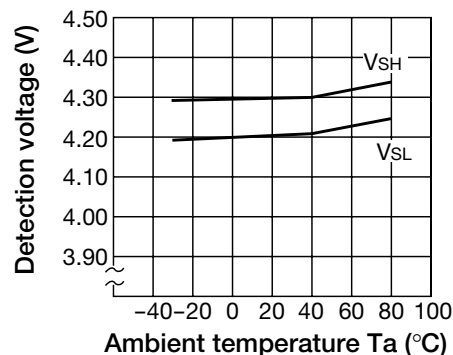

■ Output saturation voltage-Output sink current (RESET pin)

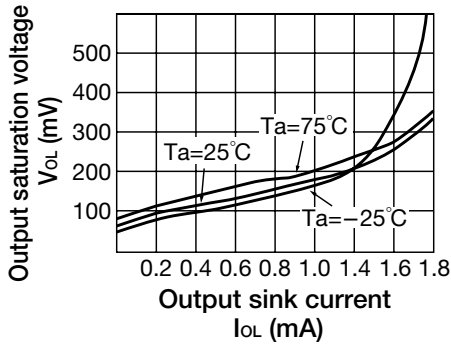

■ Output saturation voltage-Output sink current (RESET pin)

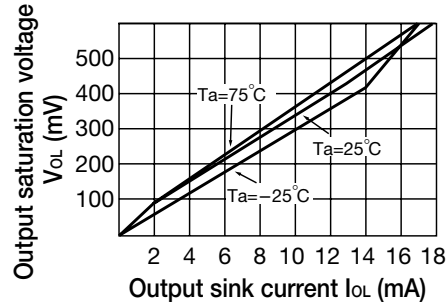

■ High level output voltage-High level output current (RESET pin)

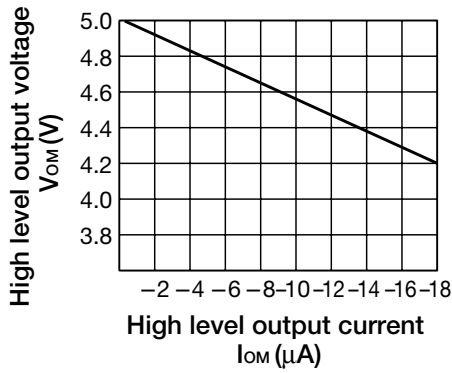

■ High level output voltage-High level output current (RESET pin)

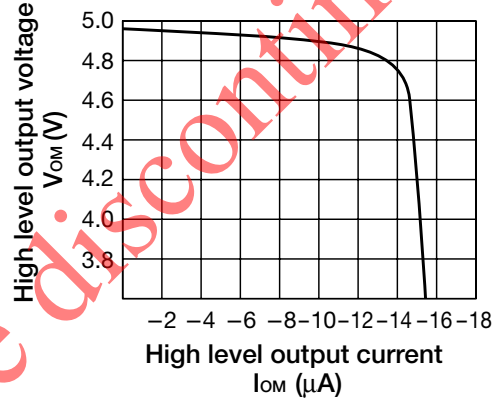

■ Reset hold time temperature during power supply rise

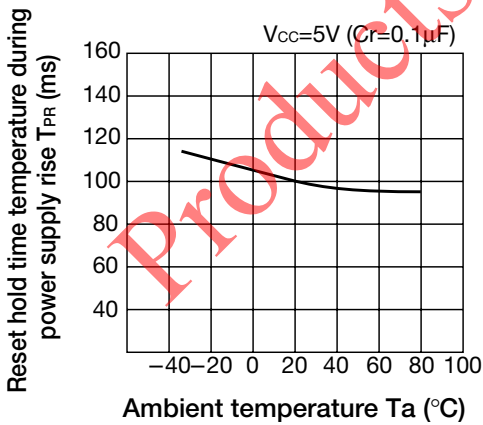

■ Watchdog timer monitoring time temperature

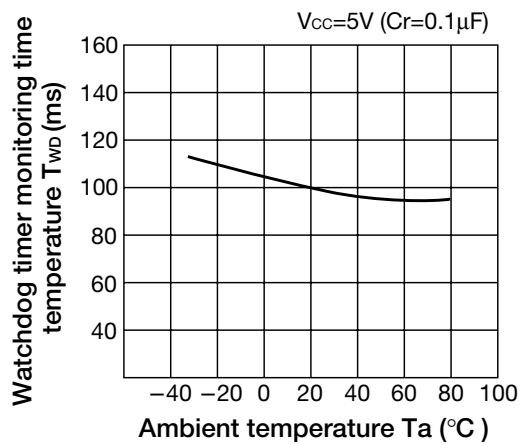

Reset time temperature (for watchdog timer)

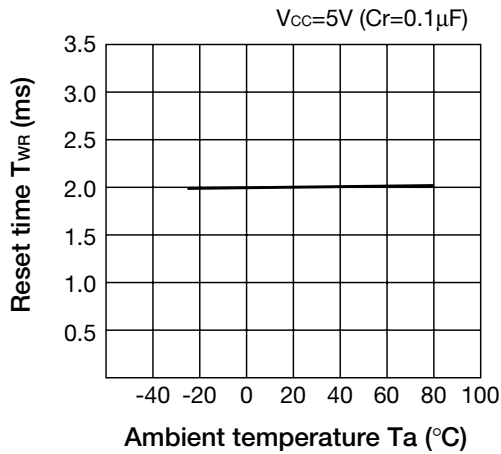

Watchdog timer monitoring time temperature

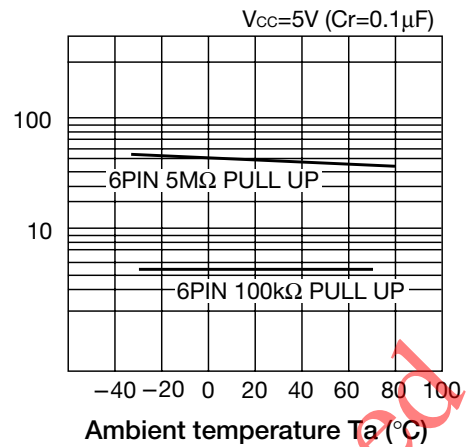

C<sub>T</sub> value for reset hold time during power supply rise

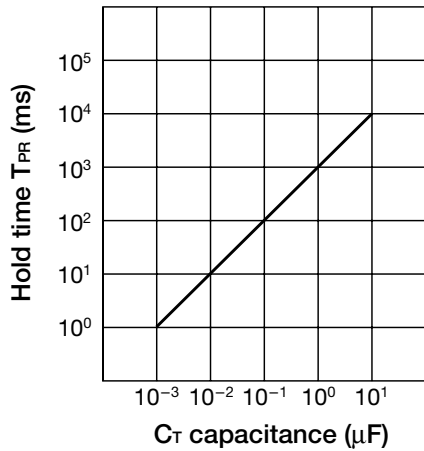

C<sub>T</sub> value for reset time (for watchdog timer)

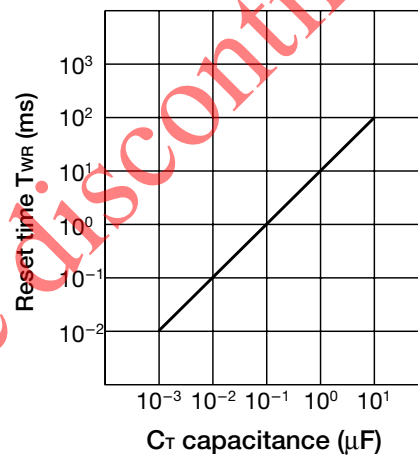

C<sub>T</sub> value for watchdog timer monitoring time

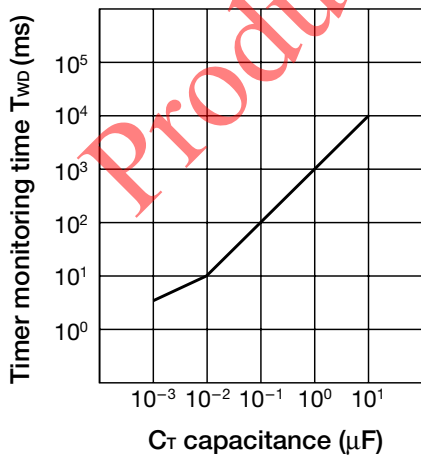

Type of timer time adjustment C<sub>T</sub> value for watchdog timer monitoring time

