

Rectangular Connectors

IAM-G63 · G89 · F30 · F33B, CAM-G62 · G62B

Connectors

FEATURES

1. These are connectors for external connection of different units. CAM-62 is the surface mounting type, and IAM-G63 has an L type plug. IAM-G89 is an L type extension cable connector.
2. A power supply pin (6 pins) is provided. Customers may choose from two types according to the application: the 6 pins type or the 2 pins type.
3. There is coupling key available, so there is no risk of miscoupling when using the same connector for multiple connections. (IAM-G89 is the key-free type, able to couple with any type.)
4. The pressure connection type with coupling pitch of 1mm and 2mm is utilized.

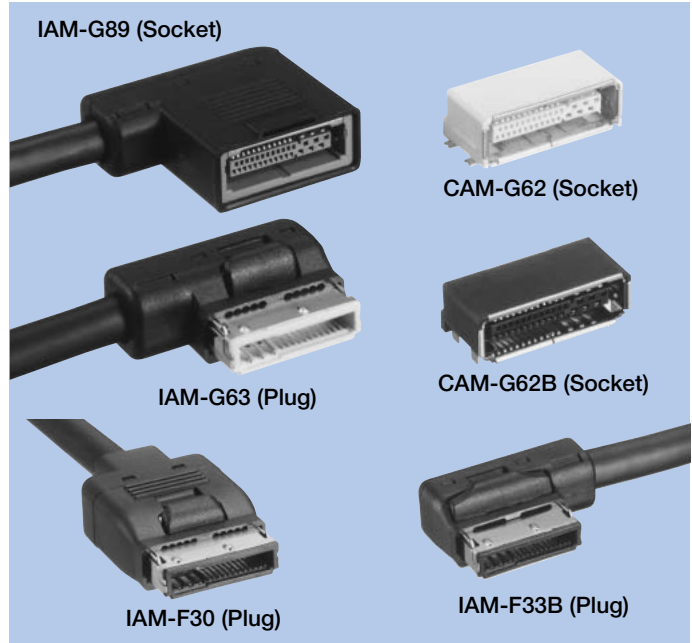

HOW TO ORDER

1. IAM-G63 (Angle Plug)

G63-030-5550 □

1 2 3

- 1 Series No. (G63 : L type)
- 2 No. of contacts (030 : 30pins)
- 3 Supplementary symbol
 A : Key-typeA Housing Black
 B : Key-typeB Housing Yellow
 C : Key-typeC Housing Brown

2. CAM-G62 (SMT Socket)

G62- □ □ □ **-230-AGGAA-** □

1 2 3

- 1 Series No. (G62 : SMT type)
- 2 No. of contacts (030 : 30pins)
(026 : 26pins)
- 3 Supplementary symbol
 A : Key-typeA Housing Black
 B : Key-typeB Housing Yellow
 C : Key-typeC Housing Brown

MATERIAL & FINISH

Component Parts		Material	Finish
IAM-G63	Housing	PBT resin	(Each color)
	Contact	Copper Alloy	Gold plating
	Shielded Case	Stainless	—
	Case	PBT resin	(Black)
	Clamper	Steel	Plating steel plate
CAM-G62 · G62B	Housing	Nylon	(Each color)
	Contact	Copper Alloy	Gold plating
	Metal Cover	Copper Alloy	Copper-tin plating
IAM-G89	Housing	PBT resin	(Gray)
	Housing for rely	PBT resin	(Black)
	Contact	Copper Alloy	Gold plating
	Contact for relay	Copper Alloy	Gold plating
	Shielded Case	Stainless	Nickel plating
	Case	PBT resin	(Black)
IAM-F30	Housing	PBT resin	(Each color)
	Contact	Copper Alloy	Gold plating
	Upper Shielded Case	Stainless	—
	Lower Shielded Case	Copper Alloy	Nickel plating
	Front Case	PBT resin	(Black)
	Rear Case	PBT resin	(Black)
	Clamper	Steel	Plating steel plate
IAM-F33B	Housing	PBT resin	(Each color)
	Contact	Copper Alloy	Gold plating
	Shielded Case A	Stainless	—
	Shielded Case B	Copper Alloy	Nickel plating
	Case	PBT resin	(Black)
	Rear Case	PBT resin	(Black)
	Clamper	Steel	Plating steel plate

DIMENSIONS

IAM-G63

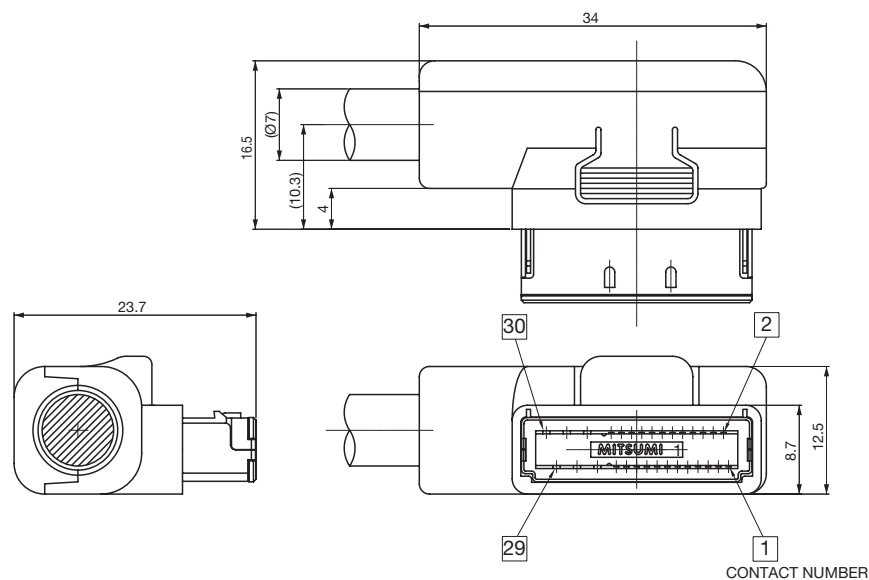

Unit : mm

CAM-G62B (30 pins)

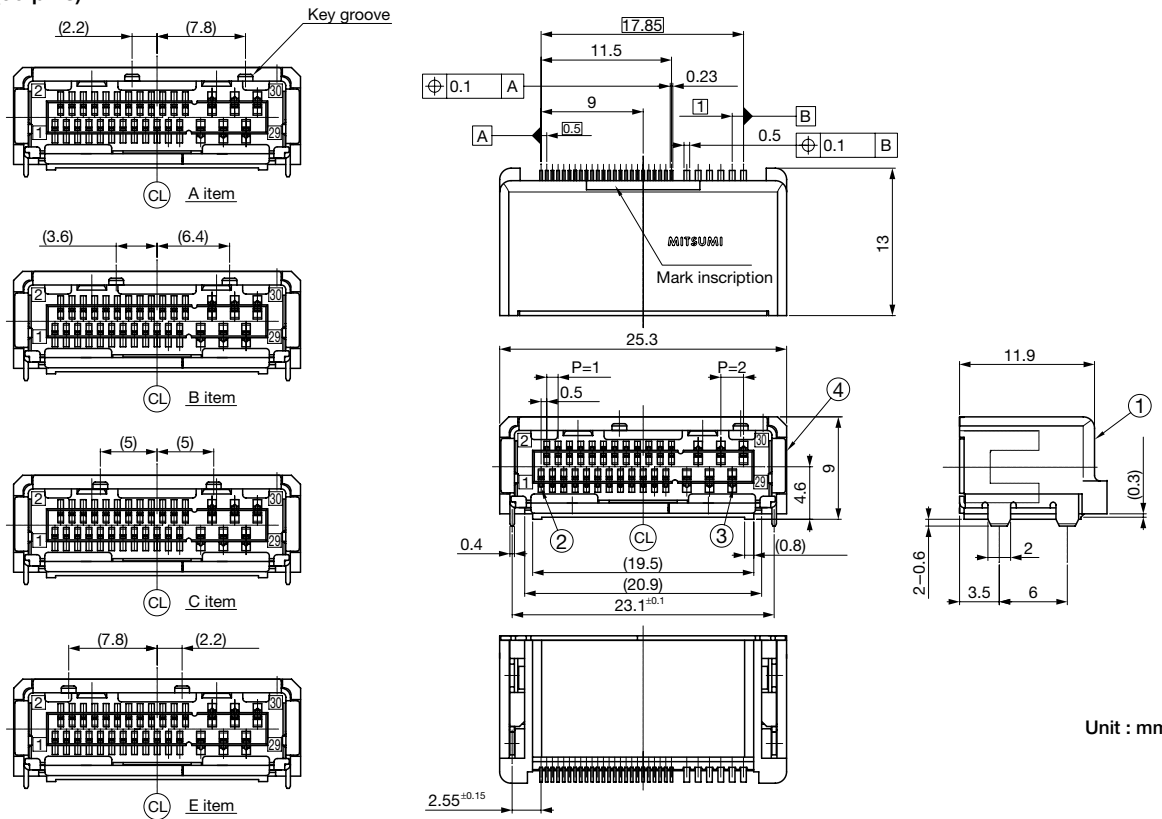

IAM-G89

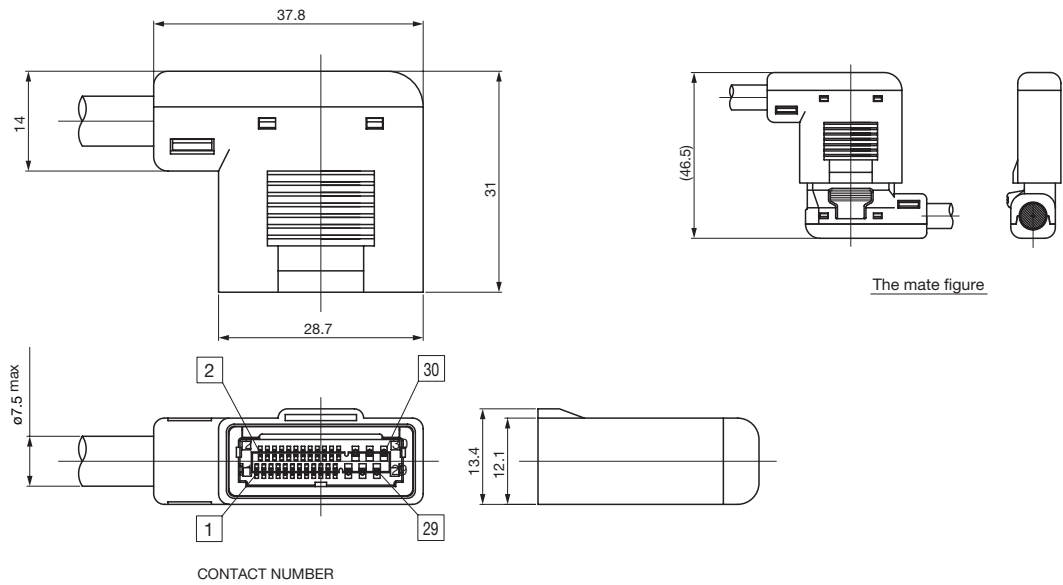

Unit : mm

IAM-F30

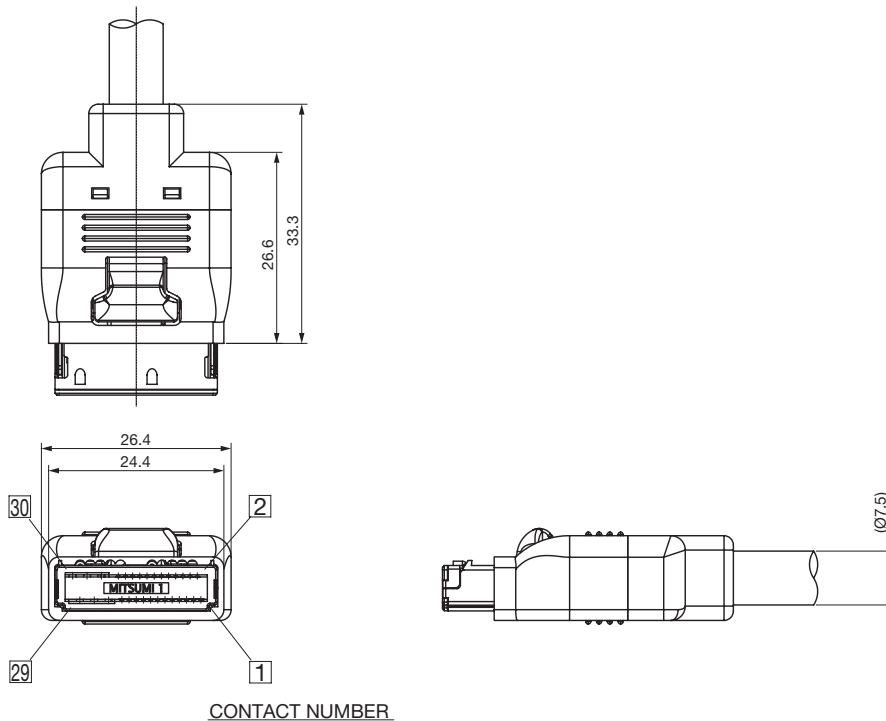

IAM-F33B

Unit : mm

