

Hybrid Driver Monolithic IC MM1285

Outline

This IC collects various driver functions used in pagers and other portable communication devices in a single chip. Recently there have been requests for more compact pagers and portable telephones, and at the same time new functions and features are being added, leading to a strong demand for miniaturized and hybrid components. This IC meets these needs through adoption of a miniature package.

The speaker driver incorporates functions for varying audio volume through data, a feature which can be used in novel applications.

Features

1. Configuration: Speaker driver, vibration motor driver, two LED drivers
2. The speaker driver is capable of varying the audio volume in four steps via parallel data
3. Power can be supplied by a single dry-cell battery
4. Low 0.1μA consumption current in standby mode

Package

TSOP-16A (MM1285XV)

Absolute Maximum Ratings

Item	Symbol	Ratings	Units
Storage temperature	T _{STG}	-40~+125	°C
Operating temperature	T _{OPR}	-10~+50	°C
Power supply voltage	V _{CC max.}	-0.3~+6	V
Operating power supply voltage	V _{CCOP}	+1.0~+1.7	V
Voltage applied to output pin	OUT1~4	-0.3~+15	V
	OUT5	-0.3~+5	V
Voltage applied to input pin		-0.3~+5	V
Allowable loss	P _d	300	mW

Pin Assignment

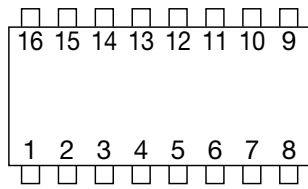

1	Vcc	9	O5
2	I1	10	O4
3	I2	11	GND
4	I3	12	O3
5	I4	13	O2
6	S1	14	O1
7	S2	15	KATHODE
8	I5	16	ANODE

I/O Timing Chart

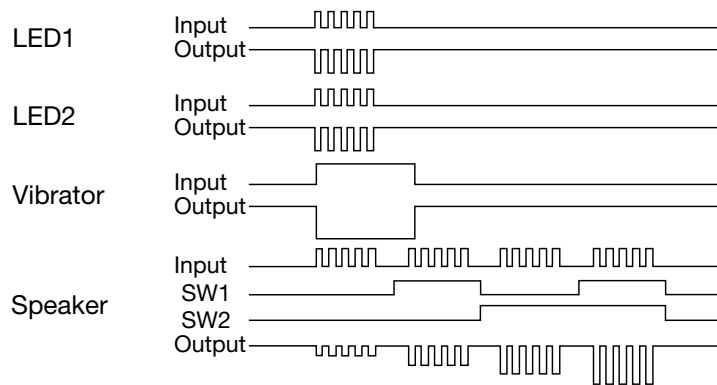

Application Circuits

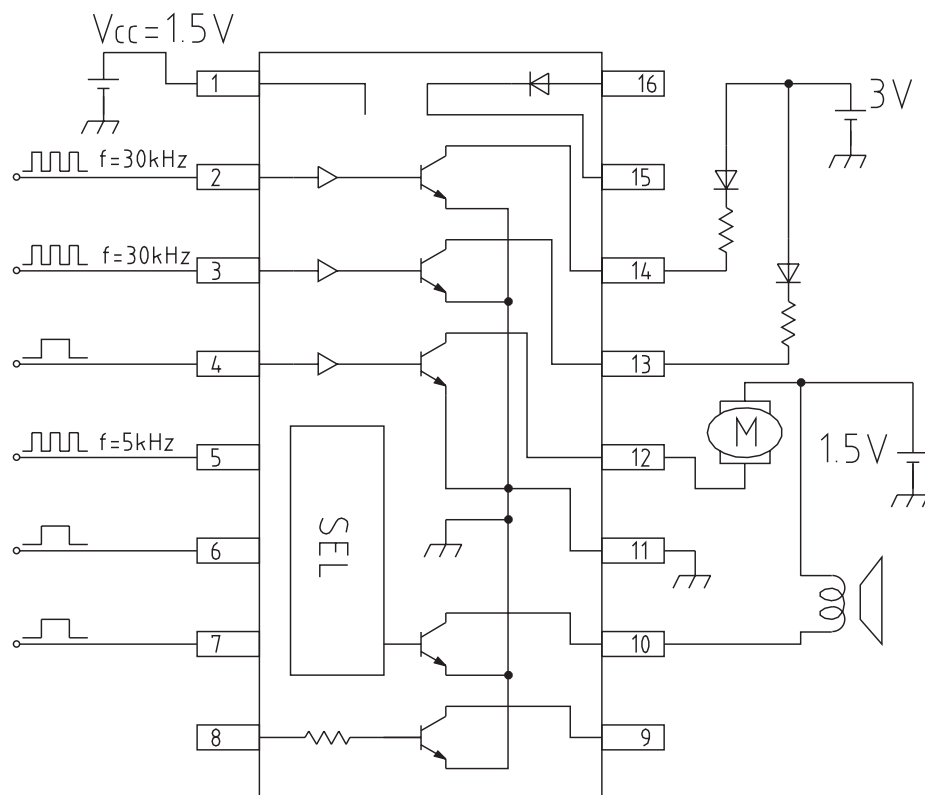

Electrical Characteristics (Except where noted otherwise, Ta=25°C, Vcc=1.5V)

Item	Measurement conditions	Min.	Typ.	Max.	Units
Standby current	All input pins=0V	-	-	0.1	μA
Consumption current A (O1 pin ON)	I1=H, another pin=L	1.4	2.2	2.9	mA
Consumption current B (O2 pin ON)	I2=H, another pin=L	1.4	2.2	2.9	mA
Consumption current C (O3 pin ON)	I3=H, another pin=L	7.0	11.0	14.5	mA
Consumption current D (O4 pin ON)	I4=H, S1=H, S2=H, another pin=L	7.0	11.0	14.5	mA
Consumption current E (O4 pin ON)	I4=H, S1=H, S2=H, another pin=L	3.5	5.5	8.0	mA
Consumption current F (O4 pin ON)	I4=H, S1=H, S2=H, another pin=L	1.1	1.6	2.2	mA
Consumption current G (O4 pin ON)	I4=H, S1=H, S2=H, another pin=L	0.45	0.70	0.95	mA
Input threshold	All input pins	0.40	0.65	0.85	V
Input resistance value	2·3·4·5·6·7 PIN		*220k		Ω
	I5pin (8PIN) only		*10k		Ω
Input current	2·3·4·5·6·7 PIN, VIN=3V	8.3	11	16	μA
	I5pin (8PIN) only, VIN=3V	170	230	330	μA
Output resistance (O1 pin)	Io=20mA		5	10	Ω
Output resistance (O2 pin)	Io=20mA		5	10	Ω
Output resistance (O3 pin)	Io=180mA		1	1.5	Ω
Output resistance A (O4 pin)	Io=100mA, S1=H, S2=H		1	1.5	Ω
Output resistance B (O4 pin)	Io=50mA, S1=L, S2=H	7	10	13	Ω
Output resistance C (O4 pin)	Io=5mA, S1=H, S2=L	38.5	55	71.5	Ω
Output resistance D (O4 pin)	Io=1mA, S1=L, S2=L	154	220	280	Ω
Output current (O5 pin)	V (I5) =1.5V, V (O5) =0.5V	2	10	-	mA
O5 pin acquisition current	V (I5) =0V, V (O5) =5V	-	-	0.1	μA
O5 pin voltage	V(I5)=0.85V, pulled up to 2V by 1MΩ	-	-	0.05	V
ON transport delay time A	I1=L→H		*0.3		μs
OFF transport delay time A	I1=H→L		*0.9		μs
ON transport delay time B	I2=L→H		*0.3		μs
OFF transport delay time B	I2=H→L		*0.9		μs
ON transport delay time C	I3=L→H		*0.3		μs
OFF transport delay time C	I3=H→L		*1.4		μs
ON transport delay time D	I4=L→H, S1=H, S2=H		*0.5		μs
OFF transport delay time D	I4=H→L, S1=H, S2=H		*1.0		μs
Diode forward voltage	IF=3mA	0.65	0.70	0.75	V
Diode reverse leakage voltage	VR=5.5V			10	μA

Notes.1: Asterisks (*) indicate design values.

2: Voltages applied to input pins are to be H=1V, L=0V.