

HBS-Compatible Driver and Receiver Monolithic IC MM1192

Outline

This IC conforms to the HBS (Home Bus) specification, and has functions for reception and transmission of data. AML is adopted for the waveforms of signals handled by the transmission and reception units, designed for connection to twisted-pair lines.

The IC can be driven by a single 5V power supply, and incorporates an output transistor to reduce external components.

It connects a wide range of equipment such as telephone equipment, security devices, audio or video equipment, and air-conditioning equipment to a bus line to enable mutual communication between equipment.

Features

1. Space saving
2. High reliability
3. Replaces pulse transformers
4. Enables to drive with a single 5V power supply
5. Low cost
6. Easy circuit design
7. Few external components

Applications

1. Telephone equipment
2. Security devices
3. Audio and video equipment
4. Air-conditioning equipment
5. A wide range of other equipment and devices

Package

DIP-16B (MM1192XD)

Block Diagram

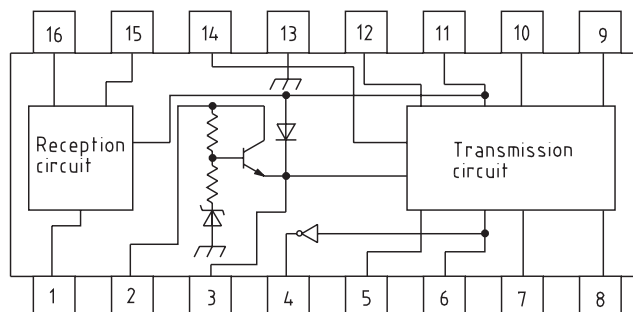

Pin Assignment

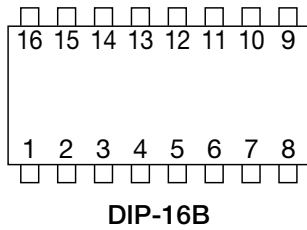

1	Reception DATA OUT	9	OUT (A)
2	V _{IN}	10	OUT (B)
3	Boost capacitor pin	11	V _{CC}
4	Boost capacitor pin	12	COLLECTOR (b)
5	RESET	13	GND
6	DATA IN	14	COLLECTOR (a)
7	out (b)	15	IN (2)
8	out (a)	16	IN (1)

Absolute Maximum Ratings (Ta=25°C)

Item	Symbol	Ratings	Units
Storage temperature	T _{STG}	-40~+125	°C
Operating temperature	T _{OPR}	-20~+70	°C
Power supply voltage	V _{CC max.}	-0.3~+7	V
Operating power supply voltage	V _{CCOP}	4.5~5.5	V
Allowable loss	P _d	450	mW
Recommended power supply voltage range	V _{CCOP2}	4.75~5.25	V
Bias voltage range (V _{IN})	V _{INOP}	8.0~40	V

Electrical Characteristics (Except where noted otherwise, Ta=25°C, V_{CC}=5V, F_{transmit}=10kHz (DUTY=50%) R_L=36Ω)

Item	Symbol	Measurement conditions	Min.	Typ.	Max.	Units		
Transmission Circuits	Power supply current 1	ICCO	No signal (5PIN="H")		8	13	mA	
	Power supply current 2	ICCON	In transmission FL=10kHz, R _L =36Ω		75	90	mA	
	Transmission output voltage	V _{TO}	Both pins 9 and 10		3.8	4.2	4.6	V _{P-P}
	Transmission waveform symmetry	V _{TR}	V _{TO1} /V _{TO2}		0.75	1.0	1.25	
	Reception sensitivity	V _{RS}			0.65	0.75	0.85	V _{P-P}
	Noise resistance	V _{RN}	Level at which no errors are output		0.55			V _{P-P}
	Input impedance	R _{IN}	Both pins 15 and 16		25	36	46	kΩ
	Transmission delay time 1	T _{d1}	cf. transmit/receive waveform diagrams			0.4		μs
	Transmission delay time 2	T _{d2}	cf. transmit/receive waveform diagrams			0.5		μs
	Transmission delay time 3	T _{d3}	cf. transmit/receive waveform diagrams			1.0		μs
	Transmission delay time 4	T _{d4}	cf. transmit/receive waveform diagrams			1.2		μs
	Reception output H voltage	V _{ROH}			4.5			V
	Reception output L voltage	V _{ROL}					0.5	V
	Transmission waveform LOSS 1	V _{TLS1}	V _T =5V applied, power on		4.5			V
	Transmission waveform LOSS 2	V _{TLS2}	V _T =5V applied, power off		4.5			V
Input/Output	H level input voltage	V _{LIH}			2.4			V
	L level input voltage	V _{LIL}					0.6	V
	H level input current	I _{LIH}	V _{DATA IN} =2.4V				10	μA
	L level input current	I _{LIL}	V _{DATA IN} =0.4V				-300	μA
	Bootstrap output H voltage	V _{BR}			7.5	8.0		V

When a negative voltage is applied to pins 7, 8, 9 and 10, there should be no abnormal operation of internal circuits between 0 and 6V. However, if a negative voltage exceeding -6V is applied, thyristor operation may result, so it is recommended that an external clamping diode be added.

In addition, no measures have been taken for a negative voltage at pins 12 and 14. Hence if a negative voltage is applied to pins 12 and 14, the internal transistor should not be used.

