

Power Inductors CY Series

OUTLINE

Low-height, and high current power inductor used in digital devices (DSC, DVC, PDA) and mobile phones. Several dimensions are available.



FEATURES

1. Non-Solder product by laser welding.
2. Impact-resistant structure with wider terminals.
3. High current performance.

SPECIFICATIONS

Type	Size (mm)	Height (mm)	Inductance (μH)	DC Resistance (mΩ)	Rated DC Current (A)	
					L=-10%	△ T=25K
C3-Y1.2R	3.8×3.8	1.2max.	1.2~22	69~790	0.20~1.40	0.30~1.30
C3-Y1.5R		1.5max.	1.0~47	62~938	0.25~1.90	0.43~1.80
C3-Y1.8R		1.8max.	1.2~47	68~820	0.30~1.80	0.30~1.90
C3-Y2.0R		2.0max.	2.2~47	70~600	0.28~1.30	0.50~1.60
C4-Y1.2R	4.6×4.6	1.2max.	1.0~47	62~1,360	0.28~2.10	0.40~1.70
C4-Y1.5R		1.5max.	1.0~47	70~1,170	0.38~2.60	0.42~1.75

* 3,000 Pcs/Reel

DATA LIST (C3-Y Series)

C3-Y1.2R (Height : 1.2mm max.)

Item	Stamp	Inductance			DCR (mΩ) typ.	DC Current (A)	
		(μH)	Tolerance (%)	Test Freq (kHz)		Inductance -10% typ.	Temp Δ25K typ.
DB	1R2	1.2	±30	1kHz	69	1.40	1.30
DC	1R5	1.5	±30	1kHz	92	1.20	1.10
DE	2R2	2.2	±30	1kHz	130	0.90	0.92
DF	2R7	2.7	±30	1kHz	150	0.85	0.87
DH	3R9	3.9	±30	1kHz	207	0.80	0.83
DJ	4R7	4.7	±30	1kHz	224	0.70	0.80
DK	5R6	5.6	±30	1kHz	311	0.60	0.75
DL	6R8	6.8	±30	1kHz	346	0.55	0.65
DM	8R2	8.2	±30	1kHz	379	0.50	0.55
EA	100	10	±20	1kHz	400	0.35	0.45
EB	120	12	±20	1kHz	453	0.30	0.40
EC	150	15	±20	1kHz	692	0.27	0.37
ED	180	18	±20	1kHz	732	0.25	0.35
EE	220	22	±20	1kHz	790	0.20	0.30

C3-Y1.5R (Height : 1.5mm max.)

Item	Stamp	Inductance			DCR (mΩ) typ.	DC Current (A)	
		(μH)	Tolerance (%)	Test Freq (kHz)		Inductance -10% typ.	Temp Δ25K typ.
DA	1R0	1.0	±30	1kHz	62	1.90	1.80
DC	1R5	1.5	±30	1kHz	76	1.70	1.70
DE	2R2	2.2	±30	1kHz	85	1.40	1.60
DF	2R7	2.7	±30	1kHz	94	1.25	1.50
DG	3R3	3.3	±30	1kHz	107	1.15	1.40
DH	3R9	3.9	±30	1kHz	118	1.00	1.30
DJ	4R7	4.7	±30	1kHz	135	0.95	1.20
DK	5R6	5.6	±30	1kHz	146	0.90	1.10
DL	6R8	6.8	±30	1kHz	185	0.80	1.00
DM	8R2	8.2	±30	1kHz	198	0.75	0.95
EA	100	10	±20	1kHz	212	0.50	0.90
EB	120	12	±20	1kHz	243	0.45	0.80
EC	150	15	±20	1kHz	318	0.42	0.75
ED	180	18	±20	1kHz	353	0.40	0.70
EE	220	22	±20	1kHz	507	0.37	0.55
EF	270	27	±20	1kHz	584	0.33	0.53
EG	330	33	±20	1kHz	765	0.31	0.50
EH	390	39	±20	1kHz	820	0.28	0.45
EJ	470	47	±20	1kHz	938	0.25	0.43

DATA LIST (C3-Y Series)

C3-Y1.8R (Height : 1.8mm max.)

Item	Stamp	Inductance			DCR (mΩ) typ.	DC Current (A)	
		(μH)	Tolerance (%)	Test Freq (kHz)		Inductance -10% typ.	Temp Δ25K typ.
DB	1R2	1.2	±30	1kHz	68	1.80	1.90
DD	1R8	1.8	±30	1kHz	80	1.60	1.80
DE	2R2	2.2	±30	1kHz	90	1.50	1.70
DF	2R7	2.7	±30	1kHz	98	1.30	1.55
DG	3R3	3.3	±30	1kHz	110	1.20	1.45
DH	3R9	3.9	±30	1kHz	120	1.10	1.35
DJ	4R7	4.7	±30	1kHz	135	1.00	1.25
DK	5R6	5.6	±30	1kHz	145	0.90	1.15
DL	6R8	6.8	±30	1kHz	160	0.85	1.05
DM	8R2	8.2	±30	1kHz	180	0.80	0.95
EA	100	10	±20	1kHz	195	0.70	0.85
EB	120	12	±20	1kHz	260	0.60	0.70
EC	150	15	±20	1kHz	295	0.55	0.65
ED	180	18	±20	1kHz	325	0.52	0.60
EE	220	22	±20	1kHz	350	0.48	0.55
EF	270	27	±20	1kHz	485	0.43	0.45
EG	330	33	±20	1kHz	550	0.38	0.40
EH	390	39	±20	1kHz	740	0.35	0.35
EJ	470	47	±20	1kHz	820	0.30	0.30

C3-Y2.0R (Height : 2.0mm max.)

Item	Stamp	Inductance			DCR (mΩ) typ.	DC Current (A)	
		(μH)	Tolerance (%)	Test Freq (kHz)		Inductance -10% typ.	Temp Δ25K typ.
DE	2R2	2.2	±30	1kHz	70	1.30	1.60
DF	2R7	2.7	±30	1kHz	80	1.20	1.50
DG	3R3	3.3	±30	1kHz	85	1.10	1.40
DH	3R9	3.9	±30	1kHz	95	1.00	1.30
DJ	4R7	4.7	±30	1kHz	105	0.95	1.25
DK	5R6	5.6	±30	1kHz	115	0.80	1.20
DL	6R8	6.8	±30	1kHz	120	0.75	1.15
DM	8R2	8.2	±30	1kHz	145	0.65	1.10
EA	100	10	±20	1kHz	155	0.60	1.05
EB	120	12	±20	1kHz	180	0.55	1.00
EC	150	15	±20	1kHz	220	0.50	0.90
ED	180	18	±20	1kHz	250	0.45	0.80
EE	220	22	±20	1kHz	280	0.40	0.70
EF	270	27	±20	1kHz	350	0.37	0.65
EG	330	33	±20	1kHz	480	0.35	0.60
EH	390	39	±20	1kHz	545	0.30	0.55
EJ	470	47	±20	1kHz	600	0.28	0.50

DATA LIST (C4-Y Series)

C4-Y1.2R (Height : 1.2mm max.)

Item	Stamp	Inductance			DCR (mΩ) typ.	DC Current (A)	
		(μH)	Tolerance (%)	Test Freq (kHz)		Inductance -10% typ.	Temp Δ25K typ.
DA	1R0	1.0	±30	1kHz	62	2.10	1.70
DC	1R5	1.5	±30	1kHz	74	1.60	1.60
DE	2R2	2.2	±30	1kHz	87	1.20	1.50
DF	2R7	2.7	±30	1kHz	106	1.10	1.40
DG	3R3	3.3	±30	1kHz	124	1.00	1.30
DJ	4R7	4.7	±30	1kHz	139	0.95	1.20
DK	5R6	5.6	±30	1kHz	179	0.80	1.05
DL	6R8	6.8	±30	1kHz	200	0.75	1.00
DM	8R2	8.2	±30	1kHz	277	0.65	0.90
EA	100	10	±20	1kHz	303	0.60	0.80
EB	120	12	±20	1kHz	324	0.55	0.75
EC	150	15	±20	1kHz	458	0.50	0.70
ED	180	18	±20	1kHz	636	0.40	0.60
EE	220	22	±20	1kHz	722	0.35	0.55
EF	270	27	±20	1kHz	802	0.32	0.50
EG	330	33	±20	1kHz	1,107	0.31	0.45
EH	390	39	±20	1kHz	1,202	0.30	0.43
EJ	470	47	±20	1kHz	1,360	0.28	0.40

C4-Y1.5R (Height : 1.5mm max.)

Item	Stamp	Inductance			DCR (mΩ) typ.	DC Current (A)	
		(μH)	Tolerance (%)	Test Freq (kHz)		Inductance -10% typ.	Temp Δ25K typ.
DA	1R0	1.0	±30	1kHz	70	2.60	1.75
DB	1R2	1.2	±30	1kHz	81	2.20	1.70
DD	1R8	1.8	±30	1kHz	95	1.80	1.65
DF	2R7	2.7	±30	1kHz	108	1.75	1.60
DG	3R3	3.3	±30	1kHz	125	1.65	1.55
DH	3R9	3.9	±30	1kHz	138	1.45	1.45
DJ	4R7	4.7	±30	1kHz	155	1.25	1.35
DK	5R6	5.6	±30	1kHz	170	1.15	1.25
DL	6R8	6.8	±30	1kHz	185	1.10	1.15
DM	8R2	8.2	±30	1kHz	202	1.05	1.05
EA	100	10	±20	1kHz	240	0.85	0.95
EB	120	12	±20	1kHz	296	0.82	0.85
EC	150	15	±20	1kHz	338	0.70	0.80
ED	180	18	±20	1kHz	453	0.65	0.70
EE	220	22	±20	1kHz	507	0.58	0.65
EF	270	27	±20	1kHz	672	0.50	0.55
EG	330	33	±20	1kHz	766	0.45	0.50
EH	390	39	±20	1kHz	1,043	0.40	0.45
EJ	470	47	±20	1kHz	1,170	0.38	0.42

DIMENSIONS

C3-Y Series

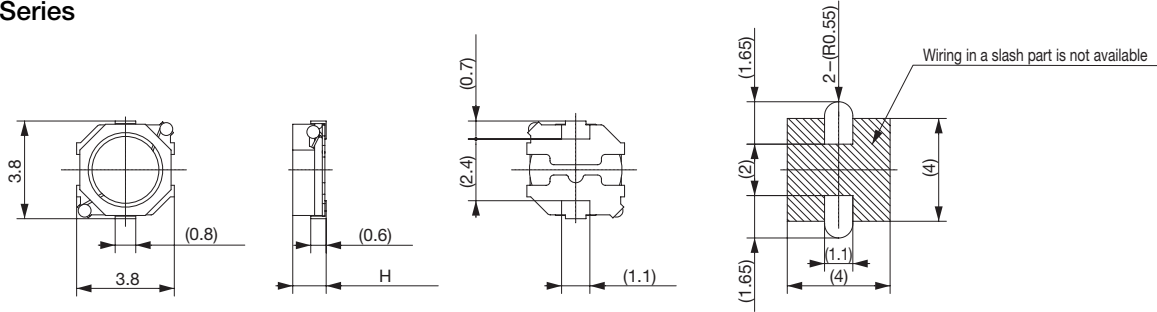

H C3-Y1.2R: 1.2max.
 1.5R: 1.5max.
 1.8R: 1.8max.
 2.0R: 2.0max.

C4-Y Series

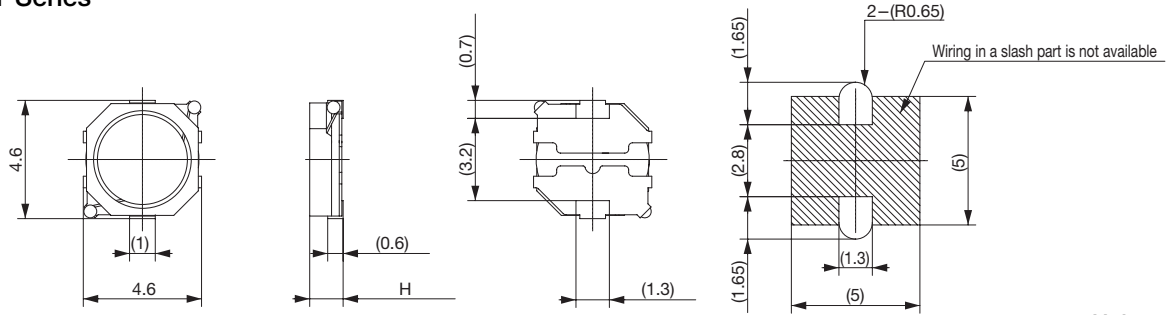

H C4-Y1.2R: 1.2max. Recommended land patterns
 1.5R: 1.5max.

Unit : mm
 Tolerance : ±0.2