

Lithium-Ion Secondary Battery Charge Control IC for AC Charger Monolithic IC MM3324

Outline

This charge control IC has characteristics to monitor battery temperature to control the charge current and charge voltage, and it is in compliance with the Safety Standard that will be put in force in 2011.

In addition, this IC has achieved high cost performance in that it has integrated with charge FET and current sensing resistor, which are the external devices in the conventional charge control ICs, and that the reverse current protection function is added.

Features

1. Integrated battery temperature monitor and battery control functions in advance preparation for the Safety Standard slated to be effective in 2011.
Safety of the battery is secured by changing the full charge voltage and charge current when the battery temperature is low and high.
2. Can reduce parts and its installation costs thanks to the integrated charging FET and current sensing resistor.
3. Because of the control function integrated in the primary side, it is also possible to charge the battery highly efficiently by tracking the battery voltage in addition to the charge control.
Furthermore, the heat dissipation is minimized.

Package

TSOP-16D

Applications

AC Charger

Block Diagram

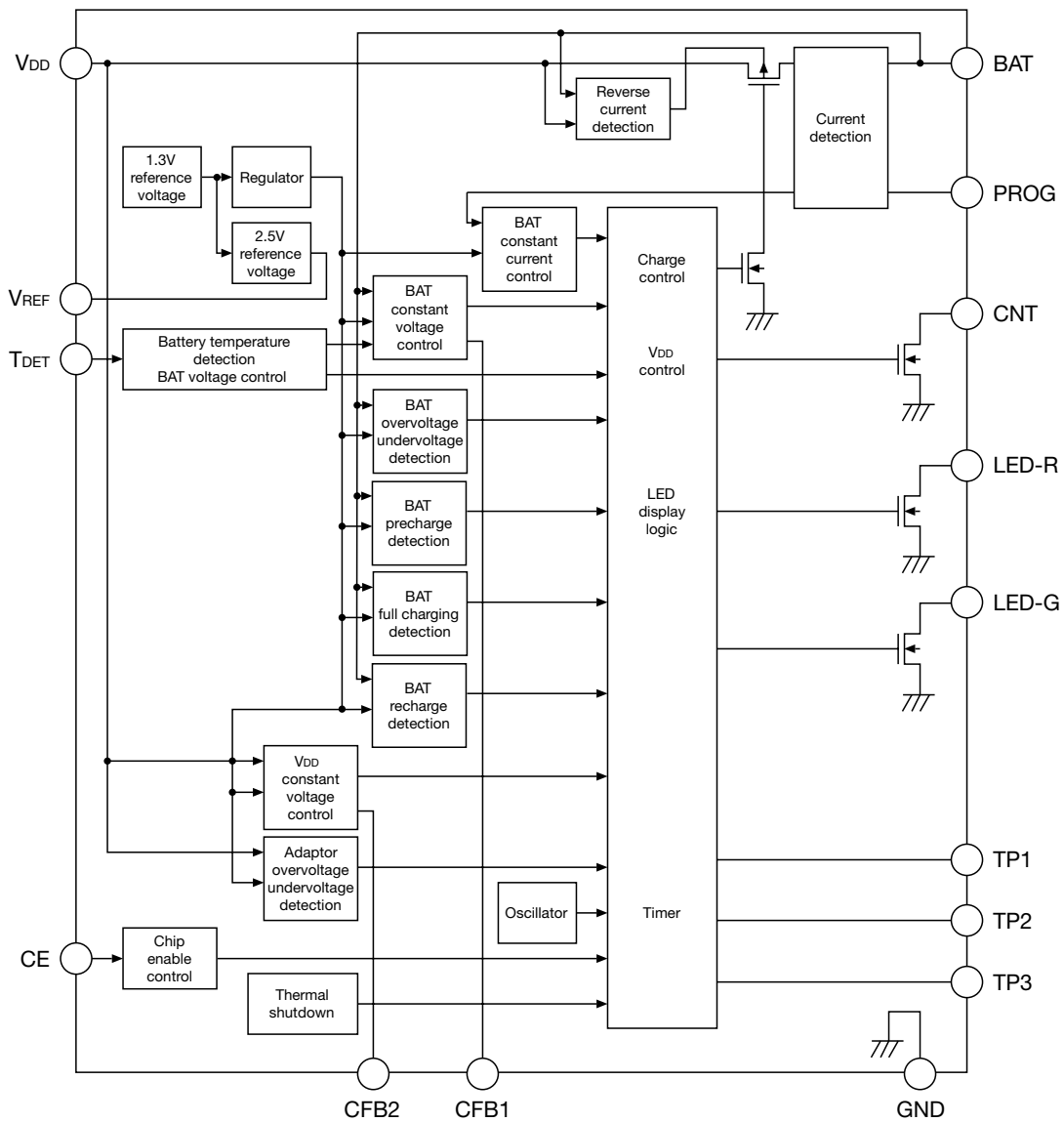

Pin Assignment

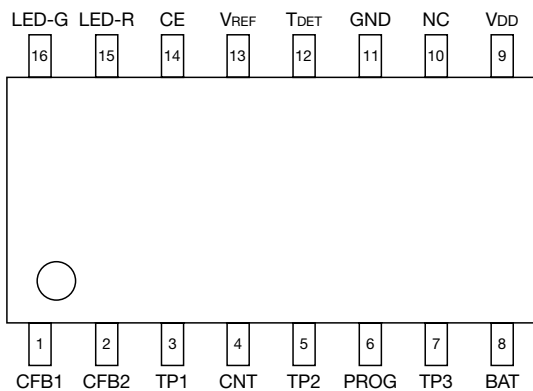

TSOP-16D
(TOP VIEW)

1	CFB1	9	V _{DD}
2	CFB2	10	NC
3	TP1	11	GND
4	CNT	12	T _{DET}
5	TP2	13	V _{REF}
6	PROG	14	CE
7	TP3	15	LED-R
8	BAT	16	LED-G

Pin Description

Pin no.	pin name	I/O	Function	Internal equivalent circuit
1	CFB1	Input	Rated BAT voltage control phase compensation pin. Oscillation is improved by connecting an external capacitor between CFB1 and CNT for phase compensation.	
2	CFB2	Input	Rated V _{DD} voltage control phase compensation pin. Oscillation is improved by connecting an external capacitor between CFB2 and CNT for phase compensation.	
3	TP1	Input	Terminal 1 for test It is a terminal for the timer test. Please connect it with the opening when you use it usually.	
4	CNT	Output	Photo diode drive pin of photo coupler for V _{DD} and BAT constant voltage and constant current control. Connect to cathode of diode.	
5	TP2	Input	Terminal 2 for test It is a terminal for the timer test. Please connect it with the opening when you use it usually.	
6	PROG	Input	It can adjust the charge current for DC input (V _{DD}) with the value of an external resistor. If setting this value smaller, the charge current can be larger.	
7	TP3	Input	Terminal 3 for test It is a terminal for the timer test. Please connect it with the opening when you use it usually.	

Pin no.	pin name	I/O	Function	Internal equivalent circuit
8	BAT	Input	Battery voltage output pin. Detect battery voltage and control charging.	
9	V _{DD}	Input	Power supply input pin.	
10	NC		NC	
11	GND	Input	Ground pin.	
12	T _{DET}	Input	Temperature detection input pin. Apply potential resistance divided by external resistor and thermistor from reference voltage when using. Reset state will exist if T _{DET} pin does not reach the specified potential.	
13	V _{REF}	Output	Reference power supply output pin. Outputs about 2.5Volts typ. reference voltage. Used for temperature detection reference power supply.	
14	CE	Input	Chip enable pin. (active High)	
15	LED-R	Output	LED-R output pin. NMOS-Tr open drain output.	
16	LED-G	Output	LED-G output pin. NMOS-Tr open drain output.	

Absolute Maximum Ratings (Except where noted otherwise Ta=25°C)

Item	Symbol	Ratings	Units
Storage temperature	T _{STG}	-55~+150	°C
Operating temperature	T _{OPR}	-40~+85	°C
Supply voltage	V _{DDMAX}	-0.3~+6	V
Power dissipation	IC unit	Pd1	W
	Substrate mounting (*1)	Pd2	

*1 Boardsize : 50×50×1mm Material : Paper phenolic Layer : Single side Wire rate : 70%

Recommended Operating Conditions

Item	Symbol	Ratings	Units
Operating temperature	T _{OPR}	-40~+75	°C
Supply voltage	V _{OPR}	2.7~5.9	V

Electrical Characteristics (Except where noted otherwise Ta=-0~45°C, V_{CC}=5V)

Item	Symbol	Measurement Conditions	Min.	Typ.	Max.	Unit.
Consumption current	I _{DD}			1	2	mA
Reference voltage	V _{REF}			2.5		V
V _{DD} detection voltage L	V _{DDL}	V _{DD} =H→L	2.35	2.45	2.55	V
V _{DD} detection voltage L hysteresis voltage width (*1)	V _{DDLW}		50	100	150	mV
V _{DD} detection voltage H	V _{DDH}	V _{DD} =L→H	5.50	5.70	5.90	V
V _{DD} detection voltage H hysteresis voltage width (*1)	V _{DDHW}		50	100	150	mV
V _{DD} control voltage	V _{DD}		4.4	4.5	4.6	V
BAT pin leakage current	I _{BAT}				4	μA
BAT pin output voltage (V _{BAT1} >V _{BAT2})	V _{BAT1}	V _{T2} <T _{DET} ≤V _{T5}	4.170	4.200	4.230	V
	V _{BAT2}	V _{T5} <T _{DET} ≤V _{T6}	4.000	4.050	4.100	
Pre-charge current range	I _{PRECHG}	V _{LV} ≤BAT<V _P I _{PRECHG} =K _P ×(V _{PRECHG} /R _{PROG})	30		85	mA
Fast charge current range	I _{FSTCHG1}	V _P ≤BAT<V _{BAT} , V _{T2} <T _{DET} ≤V _{T3} I _{FSTCHG1} =K _P ×(V _{FSTCHG1} /R _{PROG})	225		640	mA
	I _{FSTCHG2}	V _P ≤BAT<V _{BAT} , V _{T3} <T _{DET} ≤V _{T6} I _{FSTCHG2} =K _P ×(V _{FSTCHG2} /R _{PROG})	300		850	
Pre-charge PROG pin output voltage	V _{PRECHG}	V _{LV} ≤BAT<V _P		0.20		V
Fast charge PROG output voltage	V _{FSTCHG1}	V _P ≤BAT<V _{BAT} , V _{T2} <T _{DET} ≤V _{T3}		1.50		V
	V _{FSTCHG2}	V _P ≤BAT<V _{BAT} , V _{T3} <T _{DET} ≤V _{T6}		2.00		
Charge Current set coefficient K _P	K _P			500		
Full charge PROG output voltage	V _{DETFULL}			0.2		V

Note : *1 guaranteed by design

Item	Symbol	Measurement Conditions	Min.	Typ.	Max.	Unit.
Pre-charge current accuracy	APRECHG	$I_{PRECHG}=55\text{mA}$	-35		+35	%
Fast charge current accuracy	AFSTCHG	$V_{T2} < T_{DET} \leq V_{T3}$ $I_{FSTCHG1}=410\text{mA}$	-15		+15	%
		$V_{T3} < T_{DET} \leq V_{T6}$ $I_{FSTCHG2}=550\text{mA}$	-10		+10	
Detect full charge current accuracy	ADETFULL		-35		+35	%
Low voltage detection voltage	V _{LV}	BAT=L→H	1.90	2.00	2.10	V
Low voltage detection voltage hysteresis voltage width (*1)	V _{LVW}		25	50	100	mV
Pre-charge detection voltage	V _P	BAT=L→H	2.80	2.90	3.00	V
Pre-charge detection voltage hysteresis voltage width (*1)	V _{PW}		25	50	100	mV
Re-charge detection voltage	V _R	BAT=H→L	3.85	3.90	3.95	V
Overvoltage detection voltage	V _{OV}	BAT=L→H	4.30	4.35	4.40	V
Battery Temperature detection T _{DET} pin voltage	V _{T1}	T _{DET} =L→H -30°C±6°C detection	V _{REF} ×0.937	V _{REF} ×0.957	V _{REF} ×0.971	V
	V _{T2}	T _{DET} =L→H 0°C±2°C detection	V _{REF} ×0.762	V _{REF} ×0.781	V _{REF} ×0.800	V
	V _{T3}	T _{DET} =L→H 10°C±2.5°C detection	V _{REF} ×0.649	V _{REF} ×0.677	V _{REF} ×0.705	V
	V _{T4}	T _{DET} =H→L 40°C±2.5°C detection	V _{REF} ×0.313	V _{REF} ×0.336	V _{REF} ×0.361	V
	V _{T5}	T _{DET} =H→L 45°C±2.5°C detection	V _{REF} ×0.269	V _{REF} ×0.290	V _{REF} ×0.313	V
	V _{T6}	T _{DET} =H→L 60°C±2.5°C detection	V _{REF} ×0.168	V _{REF} ×0.182	V _{REF} ×0.197	V
	V _{T7}	T _{DET} =H→L 80°C±6°C detection	V _{REF} ×0.079	V _{REF} ×0.096	V _{REF} ×0.116	V
Battery Temperature detection T _{DET} pin voltage hysteresis voltage width (*1)	V _{THW}	V _{T2} , V _{T3} , V _{T4} , V _{T5} , V _{T6}	2	5	8	°C
LED-R pin output voltage	V _{LED-R}	I _{LED-R} =10mA			0.4	V
LED-G pin output voltage	V _{LED-G}	I _{LED-G} =10mA			0.4	V
CNT pin output voltage	V _{CONT}	I _{CONT} =5mA			0.4	V
Output transistor ON resistance	R _{ON}	V _{DD} =4.2V		0.35		Ω
First time charge timer	T _{1STCHG}		119.6	149.5	179.4	s
Pre-charge timer	T _{PRECHG}		959	1199	1439	s
Fast charge timer	T _{FSTCHG}		15354	19193	23032	s
Full charge detection delay time	T _{DETFULL}		0.469	0.586	0.703	s
Overvoltage detection delay time	T _{OV}		0.058	0.073	0.088	s
Re-charge detection delay time	T _R		0.058	0.073	0.088	s

Note : *1 guaranteed by design

Item	Symbol	Measurement Conditions	Min.	Typ.	Max.	Unit.
First time voltage detection delay time	T _{FTV}		0.117	0.146	0.175	s
LED-R blinking cycle	T _{BL1}	Charge stop $V_{T1} < T_{DET} \leq V_{T2}, V_{T6} < T_{DET} \leq V_{T7}$	1.874	2.342	2.810	s
	T _{BL2}	Abnormal charge prohibition	0.937	1.171	1.405	
CE Low-Level input voltage	V _{CEL}	Charge OFF threshold	0		0.3	V
CE High-Level input voltage	V _{CEH}	Charge ON threshold	2		V _{DD}	V
CE pin input current	I _{CE}			10	20	μA

Note : * If the IC is damaged and control is no longer possible, its safety can not be guaranteed.

Please protect with something other than this IC.

- * Temperature detection is the setting value at B-Value 4250K (25/50°C)(NCP15WF104F03RC made by MURATA MANUFACTURING).
- * When the battery overdischarge condition, it fast charge current (I_{FSTCHG2})×1/10 mA charge for 149.5 seconds, and then it does not switch to pre-charging during that interval, it means the IC has identified a battery abnormality.
- * If adjacent terminals are shorted or each terminal is short with V_{DD} or GND, there is a possibility that the IC malfunctions.

Measuring Circuit

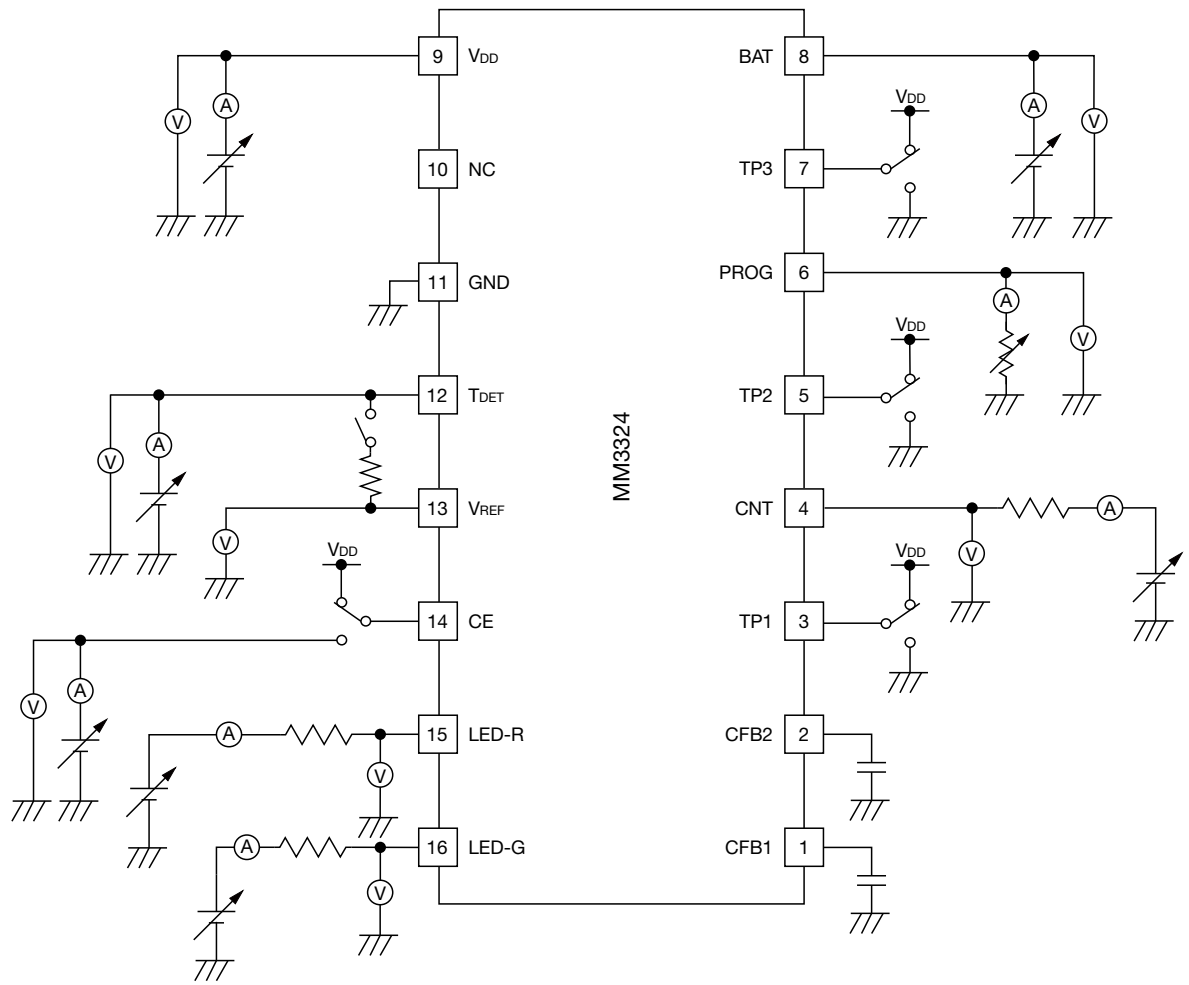

Timing Chart

Case of normal charging

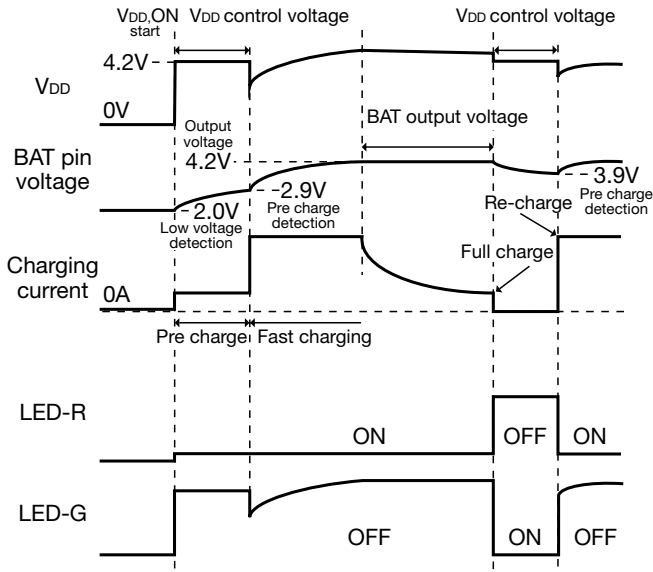

Case of connecting abnormal adapter

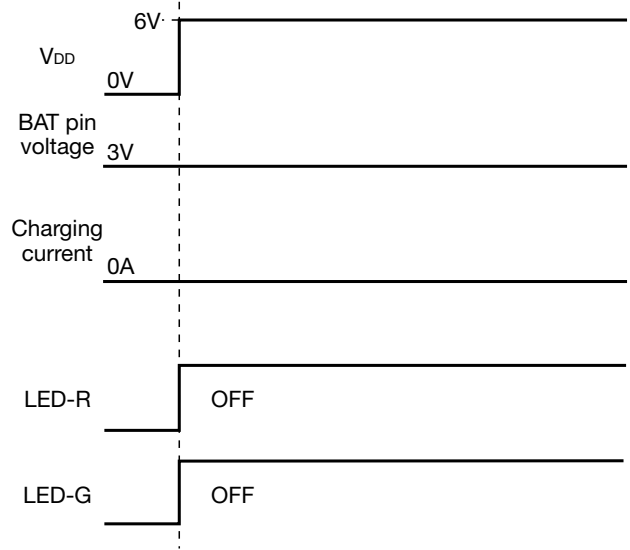

Case of setting battery error (temperature detection pin ; open)

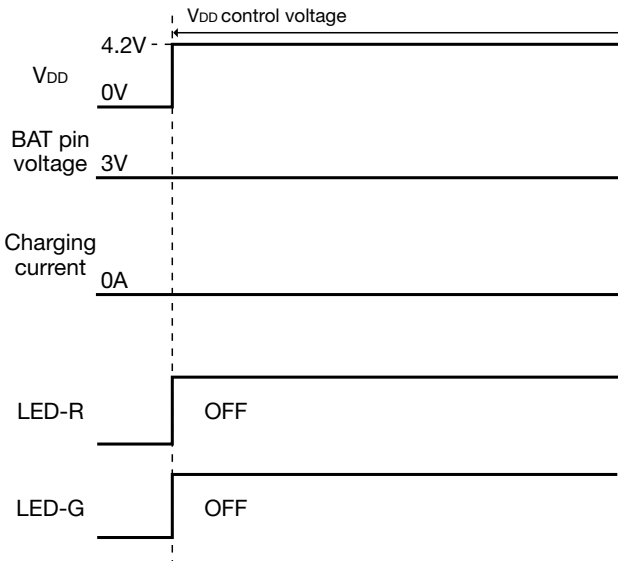

Case of overcharged battery

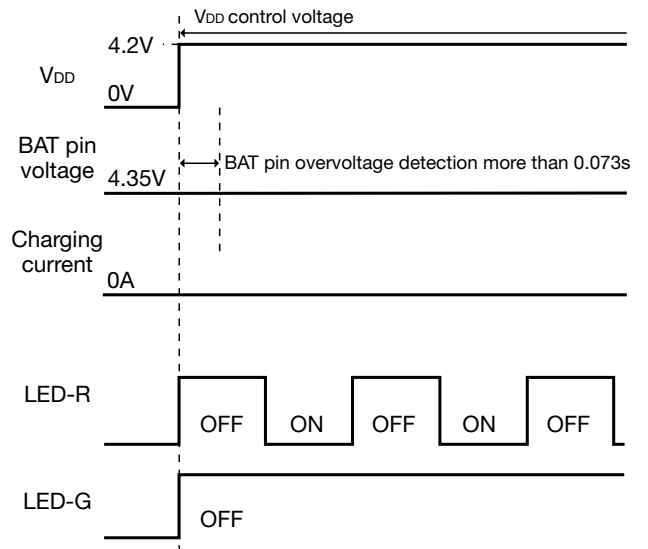

■ Case of overdischarged battery

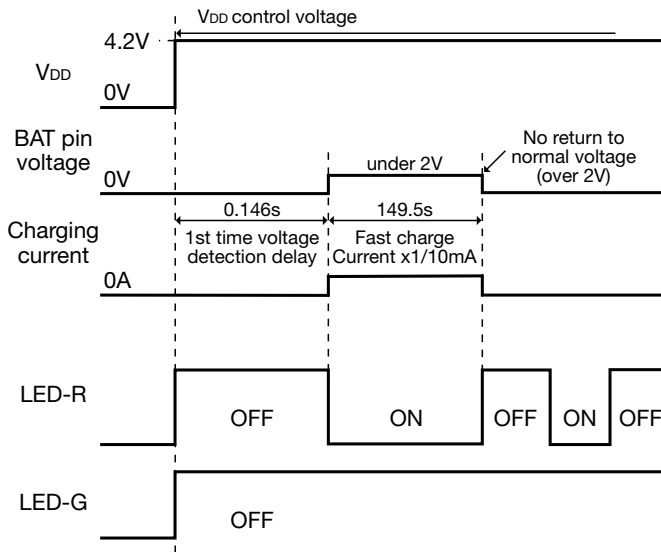

■ Case of time-up for Pre charging

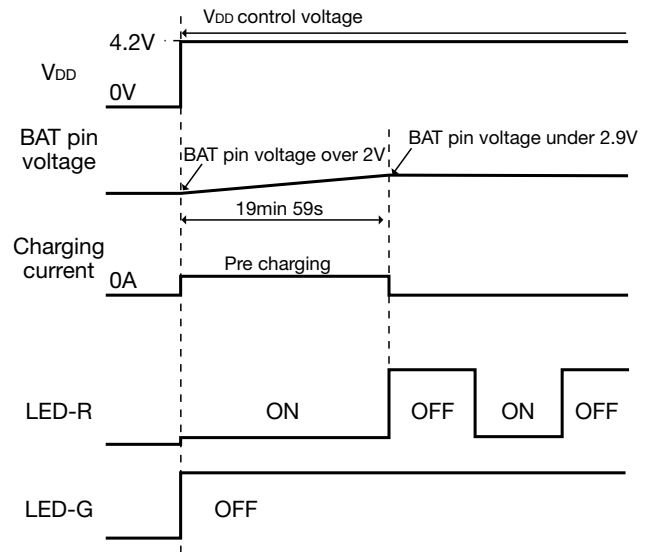

■ Case of time-up for full charging

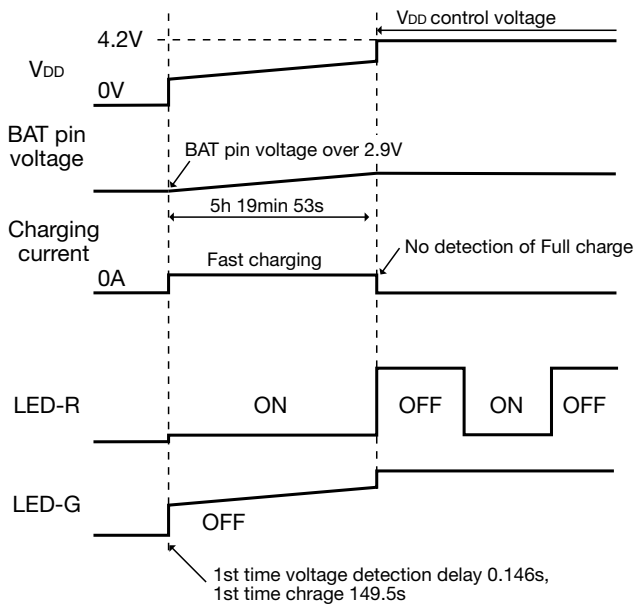

■ Case of Full charged battery

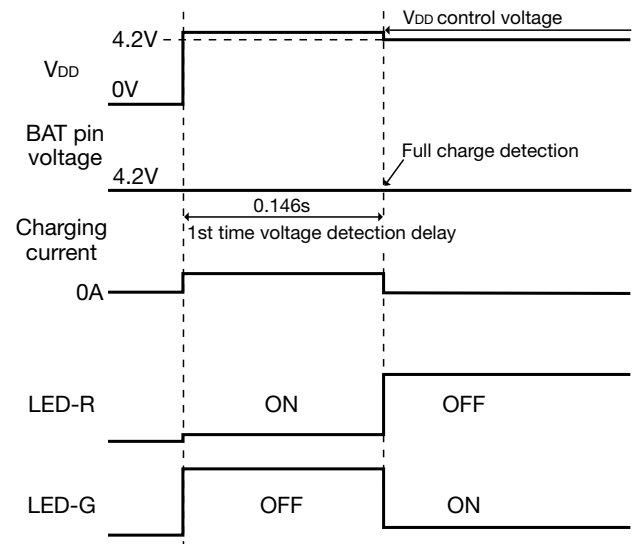

■ Case of Re-charged battery

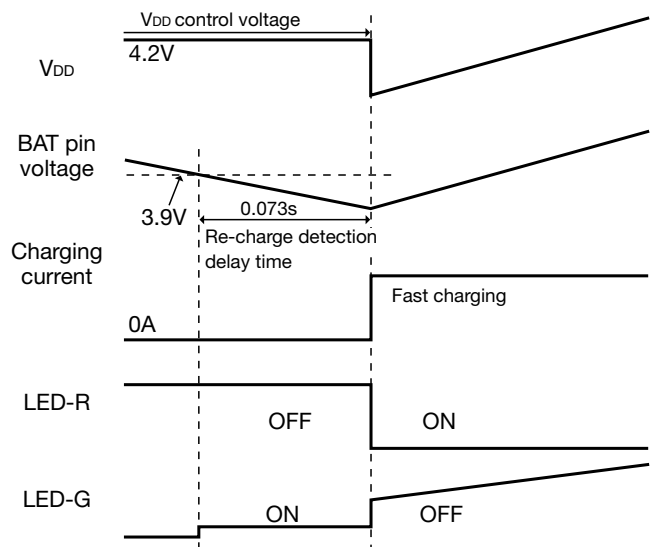

Flow Chart

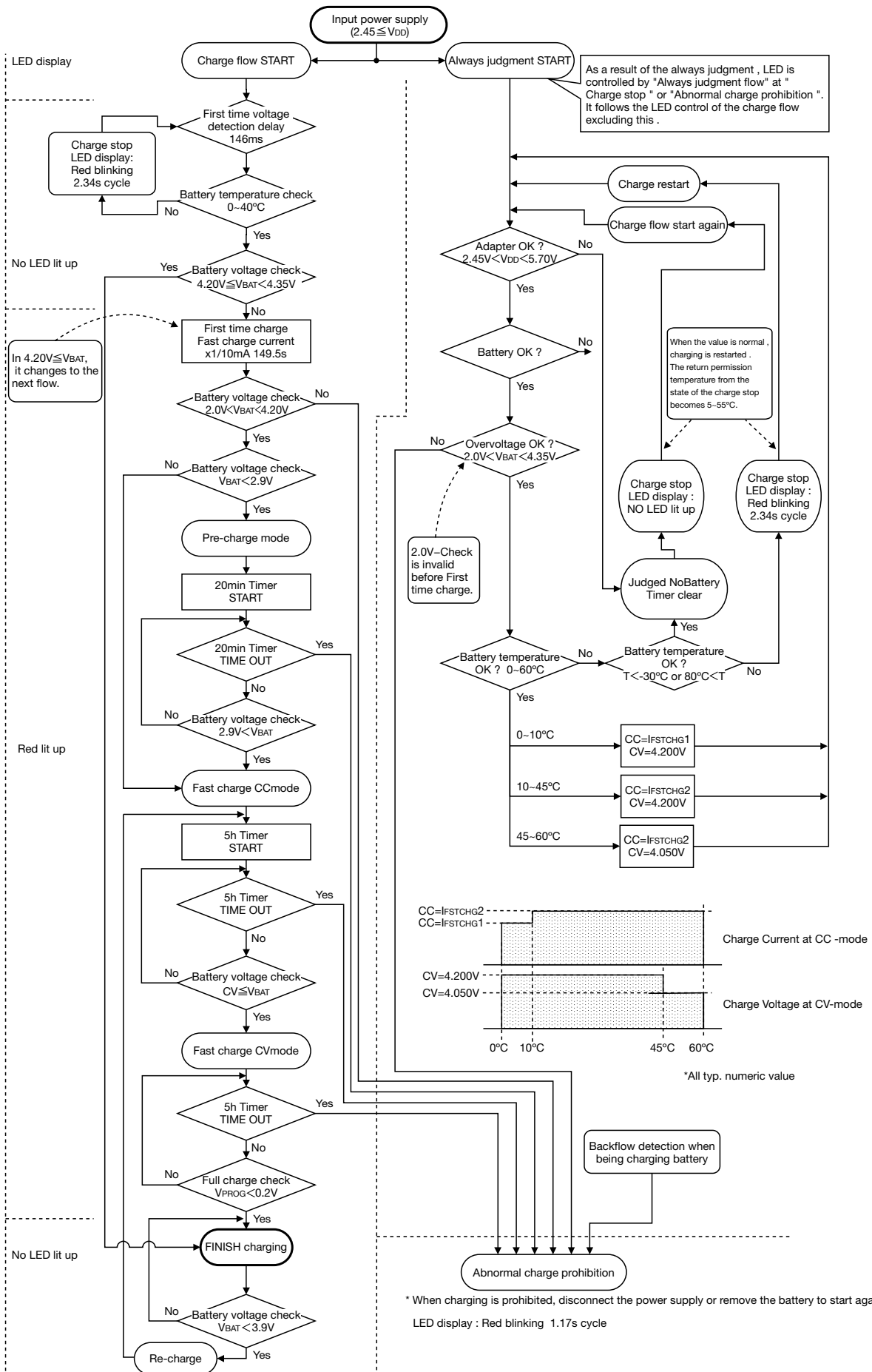

Application Circuit

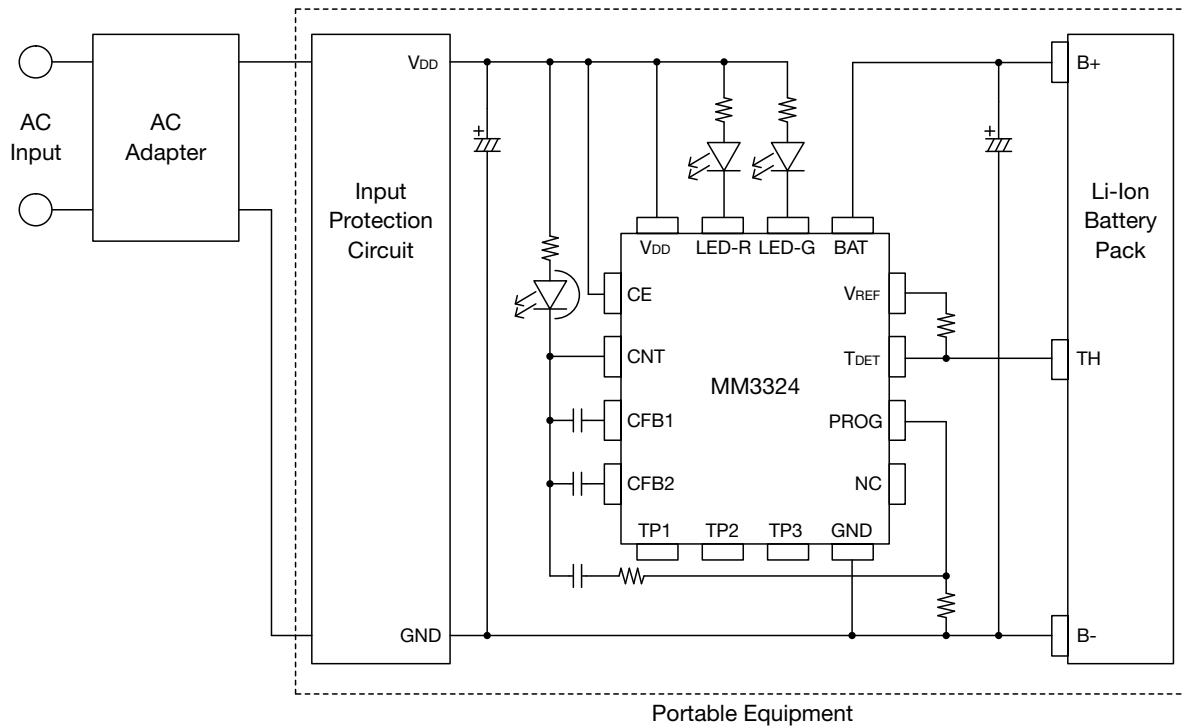

- These circuits are typical examples provided for reference purposes, so in actual applications, the circuit constants, conditions and operations should be thoroughly studied.
- Mitsumi Electric Co., Ltd. assumes no responsibility for any trouble or damage as a result of the use of these circuits.
- Mitsumi Electric Co., Ltd. assumes no responsibility for any infringement of industrial property or any other right of a third party or us, as a result of the use of these circuits.
- If terminal CNT(4pin) is short with V_{DD}, V_{DD} voltage keeps rising, and becoming it at risk.
So in actual applications, the circuit constants, conditions and operations should be thoroughly studied.