

Lithium-Ion Battery Charge Control for AC Charger Monolithic IC MM1707 Series

Outline

This IC is a one-cell lithium ion battery charge control IC for AC chargers.

The charging current and charging voltage can be optimally controlled by controlling the primary side through a photocoupler.

It incorporates a charging over timer, delay circuit for misoperation prevention, and overvoltage/overcurrent detection functions.

It includes a 2-channel LED display circuit, which allows displaying the charge status.

Features

1. Various charge control functions
2. Battery temperature detection function
3. Recharge detection function Accuracy $\pm 50\text{mV}$
4. Full-charge detection function Accuracy $\pm 3.4\text{mV}$
5. Voltage control function for the primary side of an AC adaptor
6. Abnormal battery detection function
(Overdischarge/overcharge voltage detection functions, battery temperature detection function)
7. Abnormal charge prevention function with a built-in timer
8. 2-channel LED display function
9. Misoperation prevention function with a built-in delay circuit

Package

TSOP-16A, TSOP-16B

Applications

1. Cell phones
2. Portable music players
3. Digital still cameras
4. Portable game devices
5. PDA

Block Diagram

MM1707BV

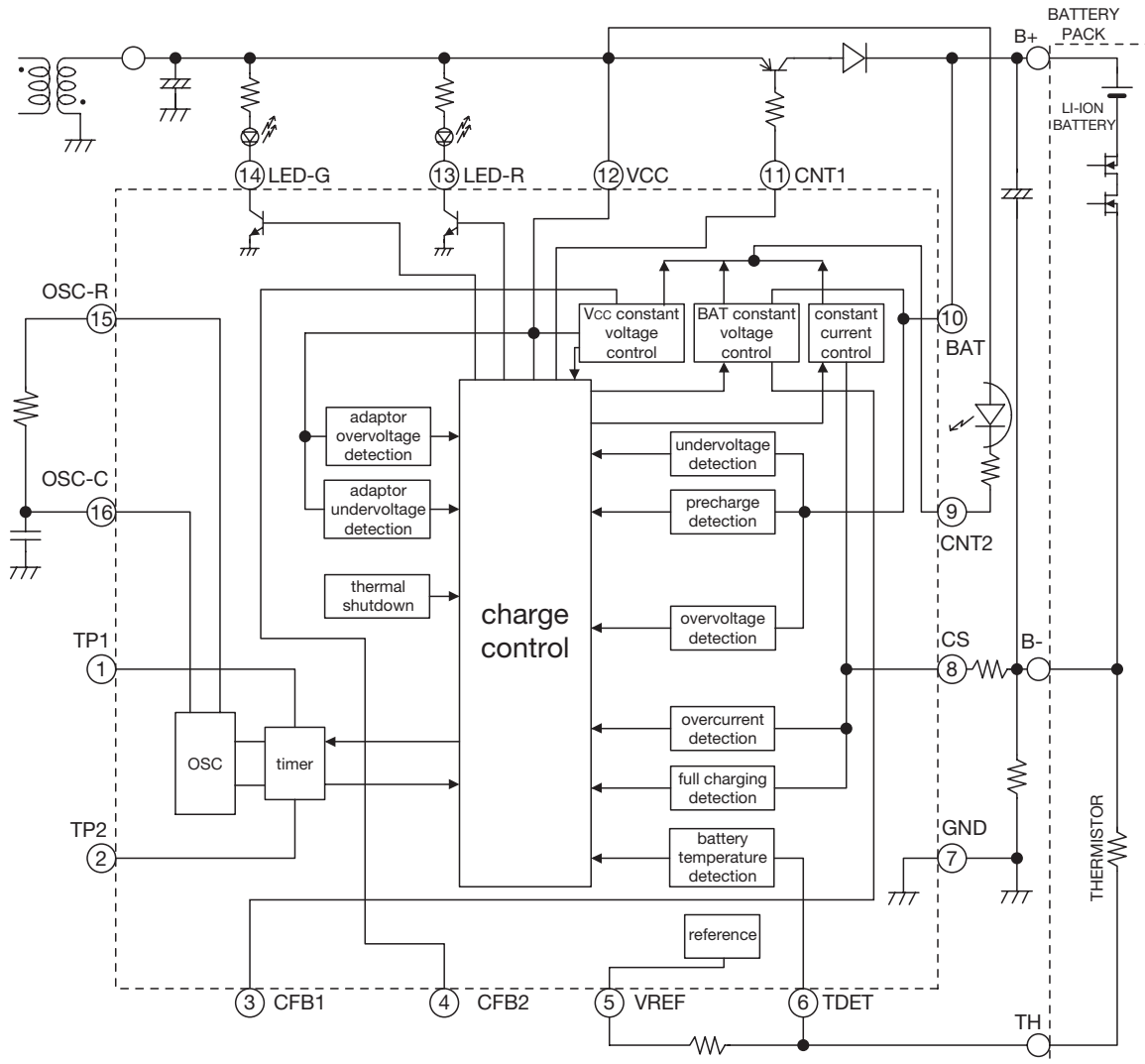

■ MM1707CV

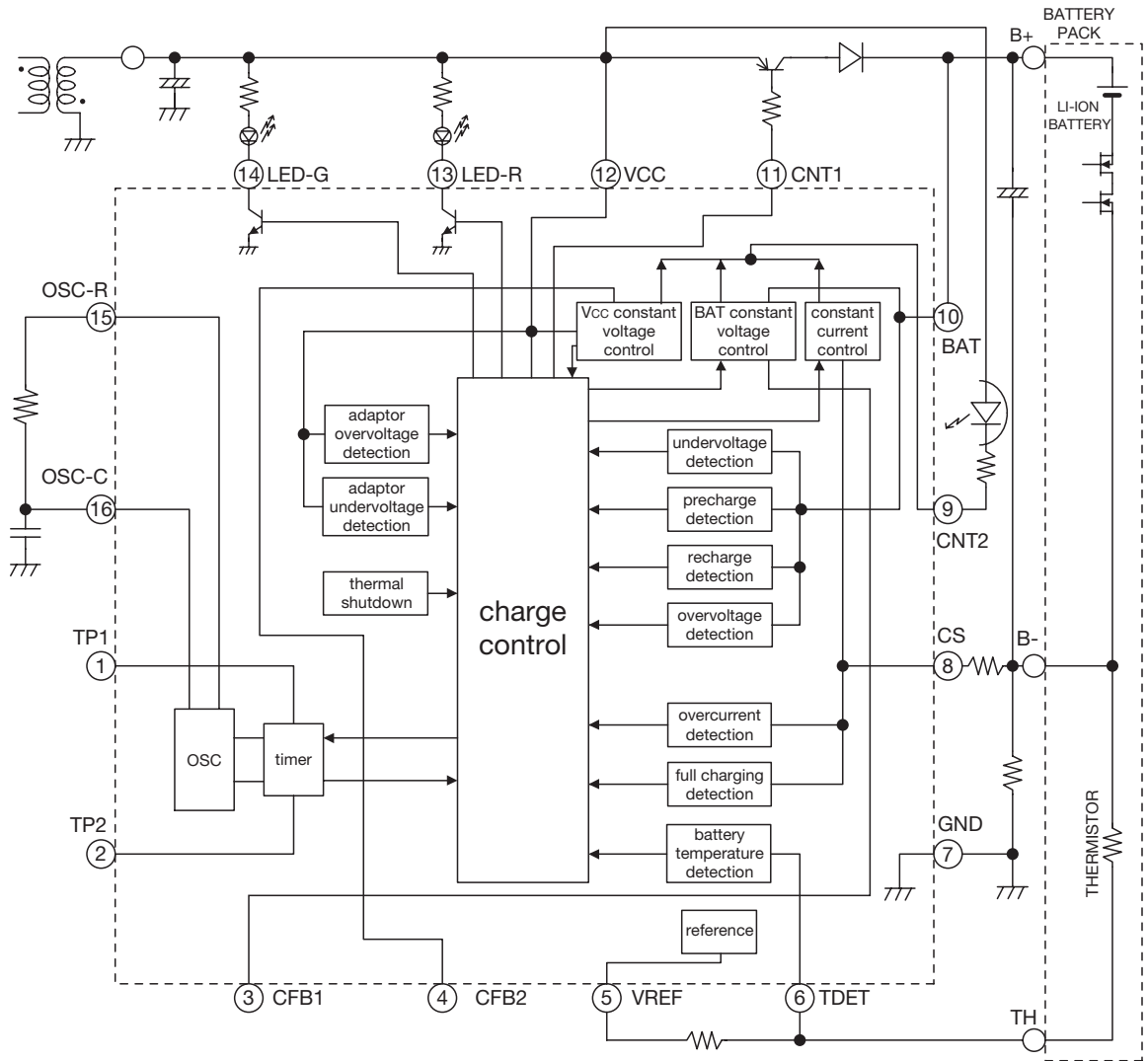

Pin Assignment

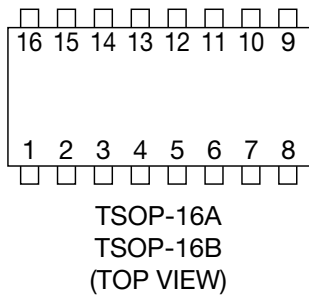

1	TP1	9	CNT2
2	TP2	10	BAT
3	CFB1	11	CNT1
4	CFB2	12	Vcc
5	VREF	13	LED-R
6	TDET	14	LED-G
7	GND	15	OSC-R
8	CS	16	OSC-C

Pin Description

Pin no.	Pin name	I/O	Function
1	TP1	OUTPUT	TEST output pin. Pre-charge timer test pin. Inverts while counting and output to TP1, to permit monitoring. Also, TP1 output signal is inverted again inside the IC and inputs to the next stage FF.
2	TP2	OUTPUT	TEST output pin. Full-charge timer test pin. Same structure as TP1.
3	CFB1	INPUT	Rated BAT voltage control phase compensation pin. Oscillation is improved by connecting an external capacitor between CFB1 and CNT2 for phase compensation.
4	CFB2	INPUT	Rated Vcc voltage control phase compensation pin. Oscillation is improved by connecting an external capacitor between CFB2 and CNT2 for phase compensation.
5	VREF	OUTPUT	Reference power supply output pin. Outputs about 1.2Volts typ. reference voltage. Used for temperature detection reference power supply .
6	TDET	INPUT	Temperature detection input pin. Apply potential resistance divided by external resistor and thermistor from reference voltage when using. Reset state will exist if TDET pin does not reach the specified potential.
7	GND	INPUT	GND pin
8	CS	INPUT	Current detection input pin. Detects charging current by external resistor (between CS and GND) voltage drop and controls charging current. The full charge current is set using following formula; $I_{chg} = V_{L1}(V) / R_1(\Omega)$
9	CNT2	OUTPUT	Photo diode drive pin of photo coupler for Vcc and BAT constant voltage and constant current control. Connect to cathode of diode.
10	BAT	INPUT	Battery voltage output pin. Detect battery voltage and control charging.
11	CNT1	OUTPUT	Charging control output pin. Controls external PNP-Tr.
12	Vcc	INPUT	Power supply input pin.
13	LED-R	OUTPUT	LED-R output pin. NPN-Tr open collector output.
14	LED-G	OUTPUT	LED-G output pin. NPN-Tr open collector output.
15	OSC-R	INPUT	Oscillator output pin Timer setting time changes according to oscillation cycle. Oscillation cycle is determined by an external resistor and capacitor.
16	OSC-C	OUTPUT	Oscillator inverted input pin.

Pin Description2

Pin no.	Pin name	Equivalent circuit diagram	Pin no.	Pin name	Equivalent circuit diagram
1	TP1		6	TDET	
2	TP2		8	CS	
3	CFB1		9	CNT2	
4	CFB2		10	BAT	
5	VREF		11	CNT1	

Pin no.	Pin name	Equivalent circuit diagram	Pin no.	Pin name	Equivalent circuit diagram
13	LED-R		15	OSC-R	
14	LED-G		16	OSC-C	

Absolute Maximum Ratings (Ta=25°C)

Item	Symbol	Ratings	Units
Storage temperature	T _{STG}	-55~+150	°C
Operating temperature	T _{OPR}	-40~+85	°C
Supply voltage	V _{DD max.}	-0.3~+12	V
Allowable loss	P _d	300	mW

Recommended Operating Conditions

Item	Symbol	Ratings	Units
Operating temperature	T _{OPR}	-40~+85	°C
Supply voltage	V _{OPR}	2.7~5.9	V

Electrical Characteristics (Except where noted otherwise Ta=25°C, Vcc=5V)

■ MM1707BV

Item	Symbol	Measurement conditions	Min.	Typ.	Max.	Units
Consumption current	I _{DD}	V _{CC} =5V		6	8.4	mA
Reference voltage	V _{REF}	V _{CC} =5V		1.238		V
V _{CC} detection voltage L	V _{VCCCL}	V _{CC} =H→L	2.35	2.45	2.55	V
V _{CC} detection voltage L hysteresis voltage width	V _{VCCCLW}		50	100	150	mV
V _{CC} detection voltage H	V _{VCCCH}	V _{CC} =L→H	6.1	6.3	6.5	V
V _{CC} detection voltage H hysteresis voltage width	V _{VCCCHW}		50	100	150	mV
V _{CC} control voltage	V _{VCC}		4.1	4.2	4.3	V
BAT pin leakage current	I _{BAT}	V _{CC} =5V, BAT=3.5V			1	μA
BAT pin output voltage	V _{BAT}	V _{CC} =5V, Ta=0~+50°C	4.170	4.200	4.230	V
Current limit 1	V _{L1}	Full charge BAT=3.5V	148	154	160	mV
Current limit 2	V _{L2}	Pre-charge BAT=2.5V	10.0	15.0	20.0	mV
Full charge detection voltage	V _F		15.0	20.0	25.0	mV
Overcurrent detection voltage	V _{OC}		170	200	220	mV
Low voltage detection voltage	V _{LV}	V _{BAT} =L→H	1.90	2.00	2.10	V
Low voltage detection voltage hysteresis voltage width	V _{LVW}		25	50	100	mV
Pre-charge detection voltage	V _P	V _{BAT} =L→H	2.80	2.90	3.00	V
Pre-charge detection voltage hysteresis voltage width	V _{PW}		25	50	100	mV
Overvoltage detection voltage	V _{OV}	V _{BAT} =L→H	4.30	4.35	4.40	V
Battery temperature detection voltage H	V _{TH}	Low temperature -3°C±3°C detection (rising threshold)	0.919	0.950	0.981	V
Battery temperature detection voltage L1	V _{TL1}	High temperature 53°C±3°C detection (falling threshold)	0.310	0.335	0.360	V
Battery temperature detection voltage L2 (abnormal reset)	V _{TL2}	High temperature 43°C±3°C detection (rising threshold)	0.394	0.423	0.452	V
TDET pin input current	I _{TDET}			30	150	nA
LED R pin output voltage	V _{LED R}	I _{LED R} =10mA			0.4	V
LED G pin output voltage	V _{LED G}	I _{LED R} =10mA			0.4	V
CNT1 pin output voltage	V _{CNT1}	I _{CNT1} =10mA			0.4	V
CNT2 pin output voltage	V _{CNT2}	I _{CNT2} =5mA			0.4	V
Oscillation cycle	T _{OSC}	Not including external deviation R=130kΩ, C=0.μF	16.47	18.3	20.13	ms

*Current limits 1, 2 and full charge detection are specified at current detection resistor voltage drop.

*If the IC is damaged and control is no longer possible, its safety can not be guaranteed.

Please protect with something other than this IC.

*Temperature detection is the setting value at B constant 3435(10KC15-1608 made by Ishizuka Denshi).

*Use a capacitor with good temperature characteristics in the oscillator. Capacitor deviation will contribute to timer error.

*The standard value of Timer error time is Pre- charge, Full charge.

■ MM1707CV

Item	Symbol	Measurement conditions	Min.	Typ.	Max.	Units
Consumption current	I _{DD}	V _{CC} =5V		6	8.4	mA
Reference voltage	V _{REF}	V _{CC} =5V		1.238		V
V _{CC} detection voltage L	V _{VCC L}	V _{CC} =H→L	2.35	2.45	2.55	V
V _{CC} detection voltage L hysteresis voltage width	V _{VCC L W}		50	100	150	mV
V _{CC} detection voltage H	V _{VCC H}	V _{CC} =L→H	6.1	6.3	6.5	V
V _{CC} detection voltage H hysteresis voltage width	V _{VCC H W}		50	100	150	mV
V _{CC} control voltage	V _{VCC}		4.1	4.2	4.3	V
BAT pin leakage current	I _{BAT}	V _{CC} =5V, BAT=3.5V			1	μA
BAT pin output voltage	V _{BAT}	V _{CC} =5V, Ta=0~+50°C	4.170	4.200	4.230	V
Current limit 1	V _{L1}	Full charge BAT=3.5V	148	154	160	mV
Current limit 2	V _{L2}	Pre-charge BAT=2.5V	24.0	30.0	36.0	mV
Full charge detection voltage	V _F		16.8	21.0	25.2	mV
Overcurrent detection voltage	V _{OC}		170	200	220	mV
Low voltage detection voltage	V _{LV}	V _{BAT} =L→H	1.90	2.00	2.10	V
Low voltage detection voltage hysteresis voltage width	V _{LV W}		25	50	100	mV
Pre-charge detection voltage	V _P	V _{BAT} =L→H	2.80	2.90	3.00	V
Pre-charge detection voltage hysteresis voltage width	V _{P W}		25	50	100	mV
Re-charge detection voltage	V _R	V _{BAT} =H→L	3.85	3.90	3.95	V
Overvoltage detection voltage	V _{OV}	V _{BAT} =L→H	4.30	4.35	4.40	V
Battery temperature detection voltage H	V _{TH}	Low temperature -3°C±3°C detection (rising threshold)	0.919	0.950	0.981	V
Battery temperature detection voltage L1	V _{TL1}	High temperature 53°C±3°C detection (falling threshold)	0.310	0.335	0.360	V
Battery temperature detection voltage L2 (abnormal reset)	V _{TL2}	High temperature 43°C±3°C detection (rising threshold)	0.394	0.423	0.452	V
TDET pin input current	I _{TDET}			30	150	nA
LED R pin output voltage	V _{LED R}	I _{LED R} =10mA			0.4	V
LED G pin output voltage	V _{LED G}	I _{LED R} =10mA			0.4	V
CNT1 pin output voltage	V _{CNT1}	I _{CNT1} =10mA			0.4	V
CNT2 pin output voltage	V _{CNT2}	I _{CNT2} =5mA			0.4	V
Oscillation cycle	T _{OSC}	Not including external deviation R=130kΩ, C=0.1μF	16.47	18.3	20.13	ms

*Current limits 1, 2 and full charge detection are specified at current detection resistor voltage drop.

*If the IC is damaged and control is no longer possible, its safety can not be guaranteed.

Please protect with something other than this IC.

*Temperature detection is the setting value at B constant 3435(10KC15-1608 made by Ishizuka Denshi).

*Use a capacitor with good temperature characteristics in the oscillator. Capacitor deviation will contribute to timer error.

*When the battery overdischarge condition, it 3mA charge for 36 seconds, and then it does not switch to pre-charging during that interval, it means the IC has identified a battery abnormality.

*The standard value of Timer error time is Pre- charge, Full charge, 3mA charge, and Blinking cycle.

Electrical Characteristics2 (OSC Capacitor setting Note)

■ Oscillation cycle

Unit: s

C \ R	R					
	75kΩ	100kΩ	120kΩ	130kΩ	150kΩ	200kΩ
0.047μF	4.9m	6.5m	7.8m	8.5m	9.8m	13.0m
0.082μF	8.7m	11.6m	13.9m	15.1m	17.4m	22.9m
0.1μF	10.7m	14.2m	16.9m	18.3m	21.1m	28.2m
0.15μF	16.0m	21.2m	25.4m	27.7m	31.8m	42.1m
0.22μF	23.2m	31.1m	37.5m	40.8m	46.5m	61.8m

■ Timer of each times

· MM1707BV

Item	Calculation formula	Examples of calculation (for C=0.01μF, R=130kΩ; T=18.3ms)
Pre-charge timer (VBAT>2.0V)	$T \times 2^{16}$	1199s (19min 59s)
Full charge timer	$T \times 2^{20}$	19189s (5h 19min 49s)
3mA charge timer	$T \times 2^{11}$	37.5s
Full charge detection delay time	$T \times 2^3$	0.146s
Overcurrent detection delay time	$T \times 2^5$	0.586s
Overvoltage detection delay time	$T \times 2^5$	0.586s
Battery temperature detection delay time	$T \times 2^1$	0.037s

T; OSC oscillation cycle

· MM1707CV

Item	Calculation formula	Examples of calculation (for C=0.01μF, R=130kΩ; T=18.3ms)
Pre-charge timer (VBAT>2.0V)	$T \times 2^{16}$	1199s (19min 59s)
Full charge timer	$T \times 2^{20}$	19189s (5h 19min 49s)
3mA charge timer	$T \times 2^{11}$	37.5s
Full charge detection delay time	$T \times 2^3$	0.146s
Overcurrent detection delay time	$T \times 2^5$	0.586s
Overvoltage detection delay time	$T \times 2^5$	0.586s
Re-charge detection delay time	$T \times 2^2$	0.073s
Battery temperature detection delay time	$T \times 2^1$	0.037s
LED-R blinking cycle	$T \times 2^7$	2.342s

T; OSC oscillation cycle

Measuring Procedures (Except where noted otherwise Ta=25°C, SW1: A, SW31: ON, SW41: A, SW51: ON, SW6: ON, SW7: A)

■ MM1707BV

Item	Measuring procedures
Consumption current	The A1 current value when SW1: B, SW2: C, SW3: OFF, SW4: B, SW5: OFF, SW6: OFF, BAT=3.5V and bias1=1.25V is I_{CC} .
Reference voltage	The T1 voltage when SW1: C, SW2: C, SW3: OFF, SW4: B, SW5: OFF, SW6: OFF and BAT=3.5V is V_{REF} .
V _{CC} detection voltage L	BAT=1.85V. Gradually decrease V _{CC} from 2.6V. The V _{CC} voltage when T2 oscillation stops is V_{CCL} .
V _{CC} detection voltage L hysteresis voltage width	BAT=1.85V. Gradually raise V _{CC} from 2.3V. The V _{CC} voltage when T2 starts to oscillate is V_{CCL2} and the difference between V_{CCL} and V_{CCL2} is V_{CCLW} .
V _{CC} detection voltage H	BAT=2.2V. Gradually raise V _{CC} from 6.05V. The V _{CC} voltage when T2 oscillation stops is V_{CCH} .
V _{CC} detection voltage H hysteresis voltage width	BAT=2.2V. Gradually raise V _{CC} from 6.55V. The V _{CC} voltage when T2 starts to oscillate is V_{CCH2} and the difference between V_{CCH} and V_{CCH2} is V_{CCHW} .
V _{CC} control voltage	BAT=2.2V. Gradually raise V _{CC} from 4V. V _{CC} when T3 switches from 5V to 0V is V_{VCC} .
BAT pin leakage current	The A2 current value when V _{CC} =5V and BAT=3.5V is I_{BAT} .
BAT pin output voltage	V _{CC} =5.0V, bias2=0.05V and SW2: B. Gradually decrease BAT from 4.05V. The BAT voltage when T3 switches from 5V to 0V is V_{BAT1} and $V_{BAT}=V_{BAT1}-0.05$.
Current limit 1 (Full charge)	V _{CC} =5V, BAT=3.5V and SW2: B. Gradually raise bias2 from 0.14V. The bias2 voltage when T3 switches from 5V to 0V is V_{L1} .
Current limit 2 (Pre-charge)	V _{CC} =5V, BAT=2.5V and SW2: B. Gradually raise bias2 from 0.01V. The bias2 voltage when T3 switches from 0V to 5V is V_{L2} .
Full charge detection voltage	V _{CC} =4.5V, BAT=4.15V and SW2: B. Gradually decrease Bias2 from 0.03V. The bias2 voltage when T5 switches from 0V to 5V is V_F .
Overcurrent detection voltage	V _{CC} =4.5V, BAT=3.5V and SW2: B. Gradually raise Bias2 from 0.16V. The bias2 voltage when T4 switches from 0V to 5V is V_{OC} .
Low voltage detection voltage	V _{CC} =4.05V and gradually raise BAT from 1.85V. The BAT voltage when T4 switches from 5V to 0V is V_{LV} .
Low voltage detection voltage hysteresis voltage width	V _{CC} =4.05V and gradually decrease BAT from 2.2V. The BAT voltage when T4 switches from 0V to 5V is V_{LV2} and the difference between V_{LV} and V_{LV2} is V_{LVW} .
Pre-charge detection voltage	V _{CC} =4.3V, bias2=0.027V, SW2: B and gradually raise BAT from 2.75V. The BAT voltage when T3 switches from 5V to 0V is V_{P1} and $V_P=V_{P1}-0.027$.
Pre-charge detection voltage hysteresis voltage width	V _{CC} =4.3V, bias2=0.027V, SW2: B and gradually decrease BAT from 3.2V. The BAT voltage when T3 switches from 0V to 5V is V_{P2} and the difference between V_{P1} and V_{P2} is V_{PW} .
Overvoltage detection voltage	V _{CC} =4.5V, bias2=0.05V and SW2: B. Gradually raise BAT from 4.05V. The BAT voltage when T6 switches from 0V to 5V is V_{OV1} , and $V_{OV}=V_{OV1}-0.05$.
Battery temperature detection voltage H	V _{CC} =4.05V, BAT=2.5V and SW1: B. Gradually raise bias1 from 0.90V. The bias1 voltage when T6 switches from 0V to 5V is V_{TH} .
Battery temperature detection voltage L1	V _{CC} =4.05V, BAT=2.5V and SW1: B. Gradually decrease bias1 from 0.40V. The bias1 voltage when T6 switches from 0V to 5V is V_{TL1} .
Battery temperature detection voltage L2	V _{CC} =4.05V, BAT=2.5V and SW1: B. Gradually decrease bias1 from 0.30V. The bias1 voltage when T6 switches from 5V to 0V is V_{TL2} .
TDET pin input current	V _{CC} =4.5V, BAT=2.5V, bias1=1.2V, SW1: B and the current value A3 is I_{TDET} .
LED R pin output voltage	V _{CC} =4.5V, BAT=2.5V, SW3: OFF, SW4: C, SW5: OFF, SW6: OFF and the T6 voltage when 10mA flows on T6 is V_{LEDR} .
LED G pin output voltage	V _{CC} =4.5V, BAT=2.5V, SW3: OFF, SW4: C, SW5: OFF, SW5: OFF and the T5 voltage when 10mA flows on T5 is V_{LEDG} .

Item	Measuring procedures
CNT1 pin output voltage	$V_{CC}=4.5V$, $BAT=3.5V$, SW3: OFF, SW4: C, SW5: OFF, SW5: OFF and the T4 voltage when 10mA flows on T4 is V_{CNT1} .
CNT2 pin output voltage	$V_{CC}=4.5V$, $BAT=2.5V$, SW3: OFF, SW4: C, SW5: OFF, SW5: OFF and the T3 voltage when 5mA flows on T3 is V_{CNT2} .
Oscillation cycle	The cycle of T2 signal when $V_{CC}=4.5V$ and $BAT=2.5V$ is T_{osc} .

■ MM1707CV

Item	Measuring procedures
Consumption current	The A1 current value when SW1: B, SW2: C, SW3: OFF, SW4: B, SW5: OFF, SW6: OFF, $BAT=3.5V$ and bias1=1.25V is I_{cc} .
Reference voltage	The T1 voltage when SW1: C, SW2: C, SW3: OFF, SW4: B, SW5: OFF, SW6: OFF and $BAT=3.5V$ is V_{REF} .
V_{CC} detection voltage L	$BAT=1.85V$. Gradually decrease V_{CC} from 2.6V. The V_{CC} voltage when T2 oscillation stops is V_{CCL} .
V_{CC} detection voltage L hysteresis voltage width	$BAT=1.85V$. Gradually raise V_{CC} from 2.3V. The V_{CC} voltage when T2 starts to oscillate is V_{CCL2} and the difference between V_{CCL} and V_{CCL2} is V_{CCLW} .
V_{CC} detection voltage H	$BAT=2.2V$. Gradually raise V_{CC} from 6.05V. The V_{CC} voltage when T2 oscillation stops is V_{CCH} .
V_{CC} detection voltage H hysteresis voltage width	$BAT=2.2V$. Gradually raise V_{CC} from 6.55V. The V_{CC} voltage when T2 starts to oscillate is V_{CCH2} and the difference between V_{CCH} and V_{CCH2} is V_{CCHW} .
V_{CC} control voltage	$BAT=2.2V$. Gradually raise V_{CC} from 4V. The V_{CC} when T3 switches from 5V to 0V is V_{VCC} .
BAT pin leakage current	The A2 current value when $V_{CC}=5V$ and $BAT=3.5V$ is I_{BAT} .
BAT pin output voltage	$V_{CC}=5.0V$, bias2=0.05V and SW2: B. Gradually decrease BAT from 4.05V. The BAT voltage when T3 switches from 5V to 0V is V_{BAT1} and $V_{BAT}=V_{BAT1}-0.05$.
Current limit 1 (Full charge)	$V_{CC}=5V$, $BAT=3.5V$ and SW2: B. Gradually raise bias2 from 0.14V. The bias2 voltage when T3 switches from 5V to 0V is V_{L1} .
Current limit 2 (Pre-charge)	$V_{CC}=5V$, $BAT=2.5V$ and SW2: B. Gradually raise bias2 from 0.02V. The bias2 voltage when T3 switches from 0V to 5V is V_{L2} .
Full charge detection voltage	$V_{CC}=4.5V$, $BAT=4.15V$ and SW2: B. Gradually decrease Bias2 from 0.03V. The bias2 voltage when T6 switches from 0V to 5V is V_F .
Overcurrent detection voltage	$V_{CC}=4.5V$, $BAT=3.5V$ and SW2: B. Gradually raise Bias2 from 0.16V. The bias2 voltage when T4 switches from 0V to 5V is V_{OC} .
Low voltage detection voltage	$V_{CC}=4.05V$ and gradually raise BAT from 1.85V. The BAT voltage when T4 switches from 5V to 0V is V_{LV} .
Low voltage detection voltage hysteresis voltage width	$V_{CC}=4.05V$ and gradually decrease BAT from 2.2V. The BAT voltage when T4 switches from 0V to 5V is V_{LV2} and the difference between V_{LV} and V_{LV2} is V_{LVW} .
Pre-charge detection voltage	$V_{CC}=4.3V$, bias2=0.027V, SW2: B and gradually raise BAT from 2.75V. The BAT voltage when T3 switches from 5V to 0V is V_{P1} and $V_P=V_{P1}-0.027$.
Pre-charge detection voltage hysteresis voltage width	$V_{CC}=4.3V$, bias2=0.027V, SW2: B and gradually decrease BAT from 3.2V. The BAT voltage when T3 switches from 0V to 5V is V_{P2} and the difference between V_{P1} and V_{P2} is V_{PW} .
Re-charge detection voltage	$V_{CC}=4.35V$, bias2=0.05V and SW2: B. Gradually decrease BAT from 4.05V. The BAT voltage when T6 switches from 5V to 0V is V_{R1} and $V_R=V_{R1}-0.05$.
Overvoltage detection voltage	$V_{CC}=4.5V$, bias2=0.05V and SW2: B. Gradually raise BAT from 4.05V. The BAT voltage when T6 switches from 0V to 5V is V_{OV1} , and $V_{OV}=V_{OV1}-0.05$.
Battery temperature detection voltage H	$V_{CC}=4.05V$, $BAT=2.5V$ and SW1: B. Gradually raise bias1 from 0.90V. The bias1 voltage when T6 switches from 0V to 5V is V_{TH} .

Item	Measuring procedures
Battery temperature detection voltage L1	$V_{CC}=4.05V$, $BAT=2.5V$ and SW1: B. Gradually decrease bias1 from 0.40V. The bias1 voltage when T6 switches from 0V to 5V is V_{TL1} .
Battery temperature detection voltage L2	$V_{CC}=4.05V$, $BAT=2.5V$ and SW1: B. Gradually decrease bias1 from 0.30V. The bias1 voltage when T6 switches from 5V to 0V is V_{TL2} .
TDET pin input current	$V_{CC}=4.5V$, $BAT=2.5V$, bias1=1.2V, SW1: B and the current value A3 is I_{TDET} .
LED R pin output voltage	$V_{CC}=4.5V$, $BAT=2.5V$, SW3: OFF, SW4: C, SW5: OFF, SW6: OFF and the T6 voltage when 10mA flows on T6 is V_{LEDR} .
LED G pin output voltage	$V_{CC}=4.5V$, $BAT=2.5V$, SW3: OFF, SW4: C, SW5: OFF, SW5: OFF and the T5 voltage when 10mA flows on T5 is V_{LEDG} .
CNT1 pin output voltage	$V_{CC}=4.5V$, $BAT=3.5V$, SW3: OFF, SW4: C, SW5: OFF, SW5: OFF and the T4 voltage when 10mA flows on T4 is V_{CNT1} .
CNT2 pin output voltage	$V_{CC}=4.5V$, $BAT=2.5V$, SW3: OFF, SW4: C, SW5: OFF, SW5: OFF and the T3 voltage when 5mA flows on T3 is V_{CNT2} .
Oscillation cycle	The cycle of T2 signal when $V_{CC}=4.5V$ and $BAT=2.5V$ is T_{osc} .

Timing Chart

MM1707BV

Case of normal charging

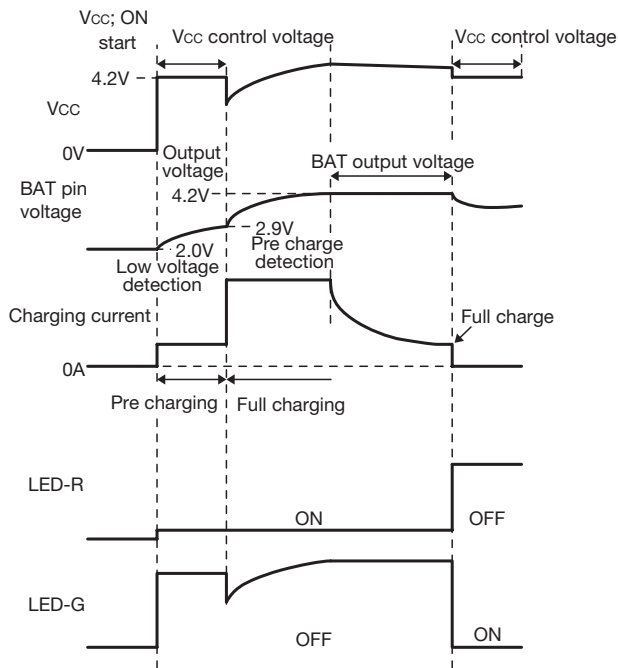

Case of connecting abnormal adapter

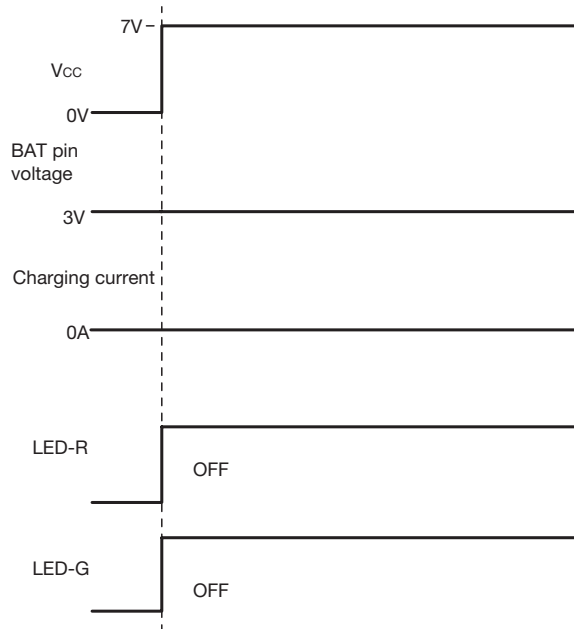

■ Case of setting battery error (temperature detection pin ; open)

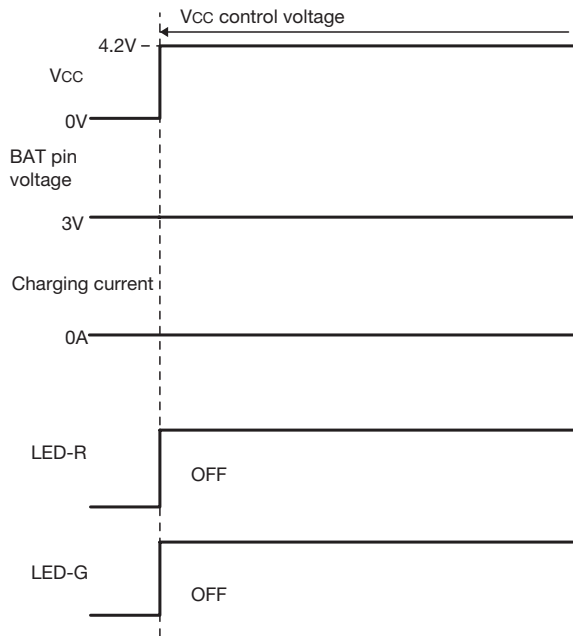

■ Case of overcharged battery

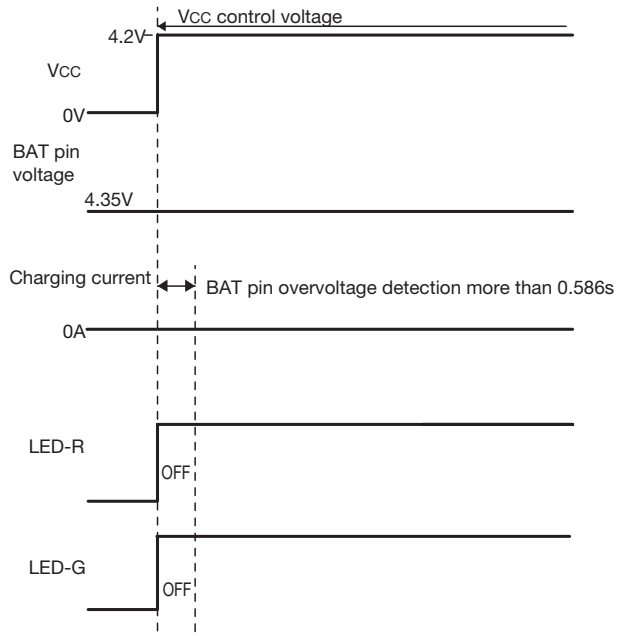

■ Case of overdischarged battery

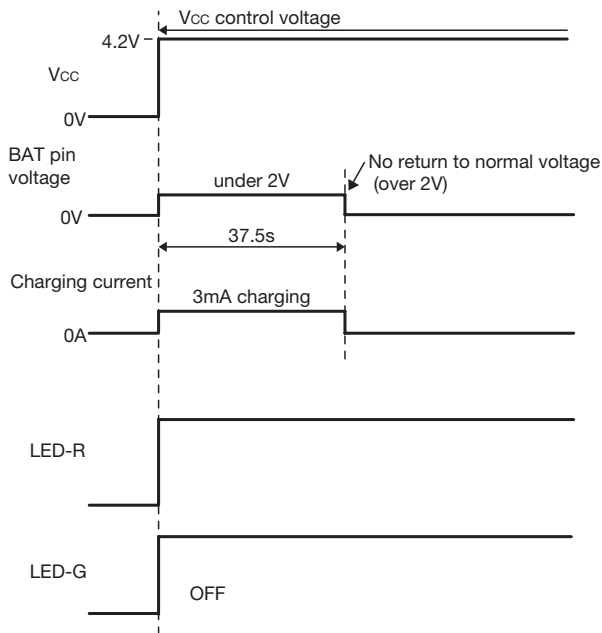

■ Case of overcurrent detection

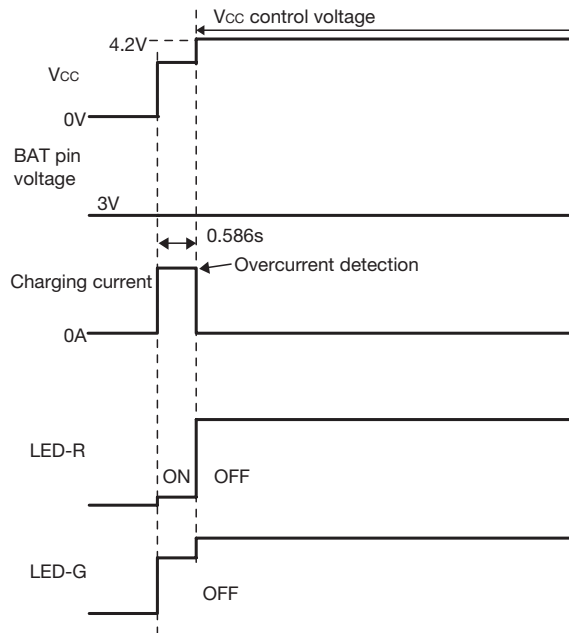

■ Case of time-up for Pre charging

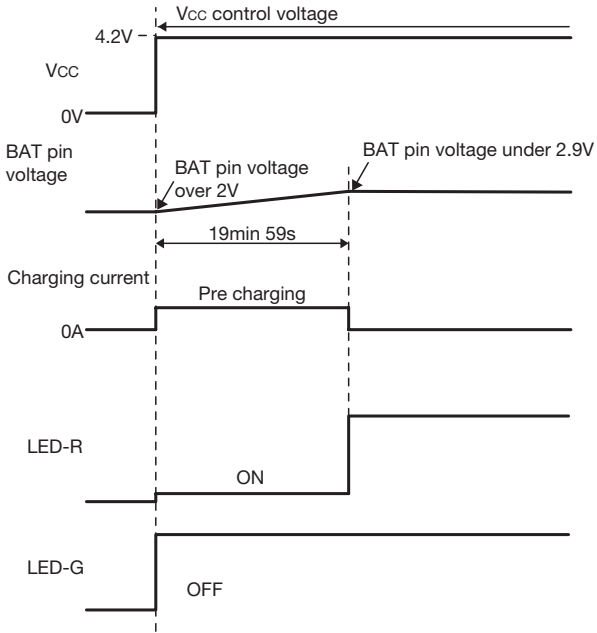

■ Case of time-up for full charging

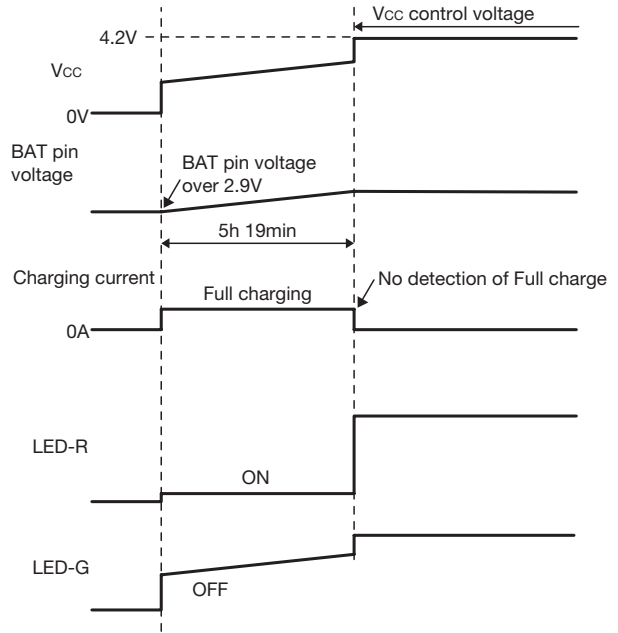

■ Case of Full charged battery

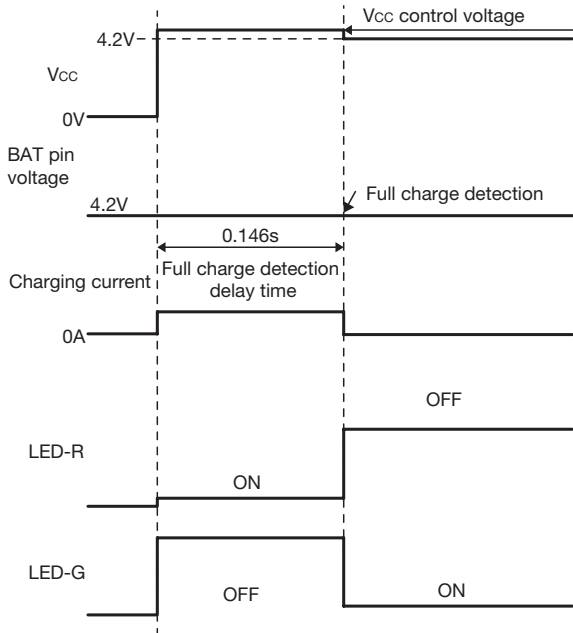

MM1707CV

Case of normal charging

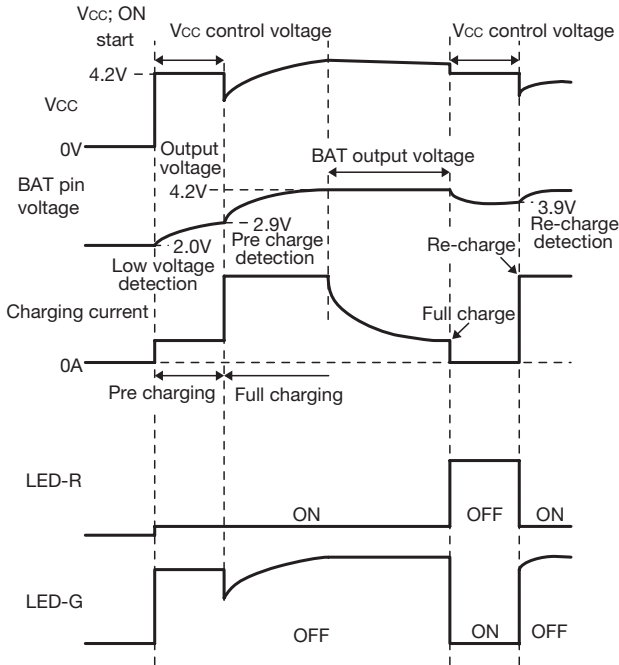

Case of connecting abnormal adapter

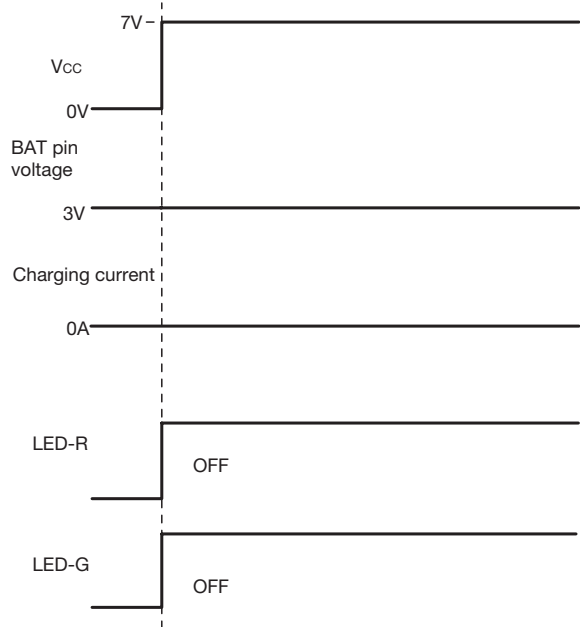

Case of setting battery error (temperature detection pin ; open)

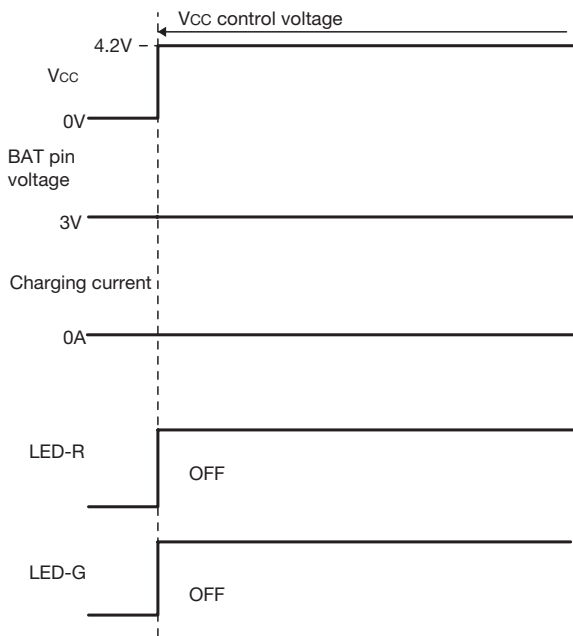

Case of overcharged battery

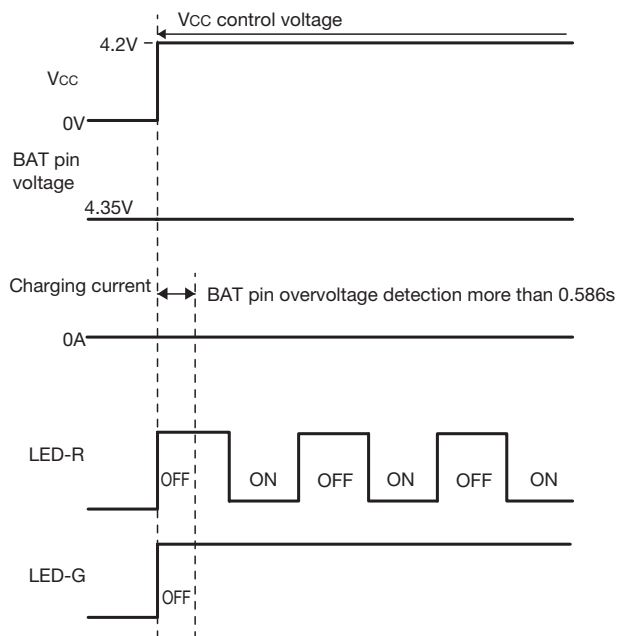

■ Case of overdischarged battery

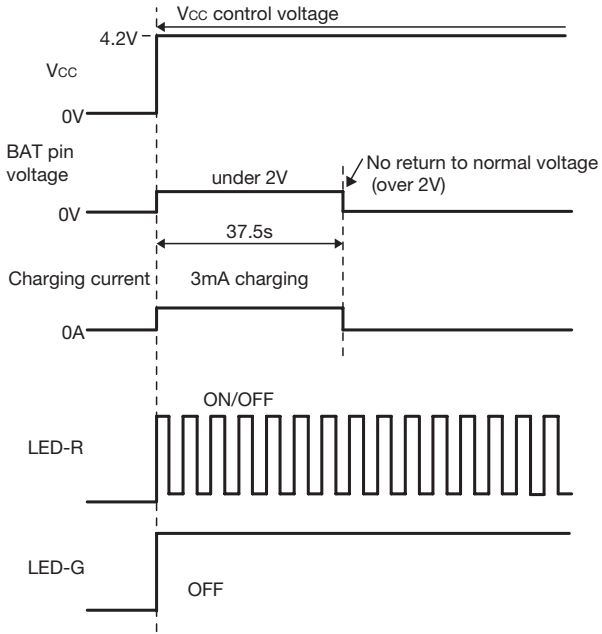

■ Case of overcurrent detection

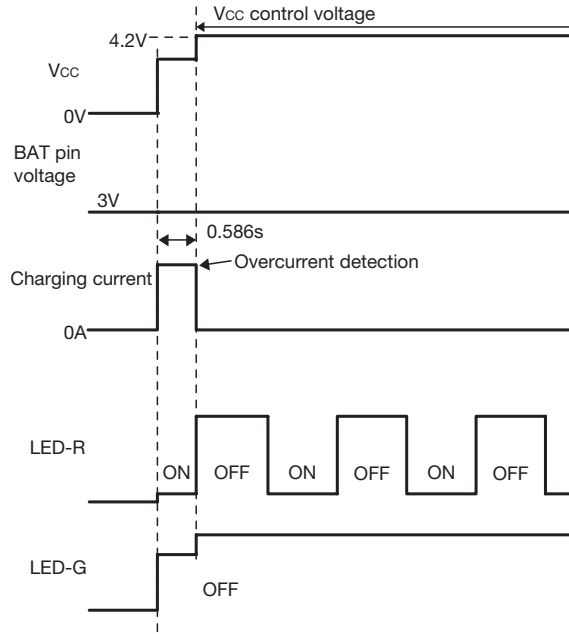

■ Case of time-up for Pre charging

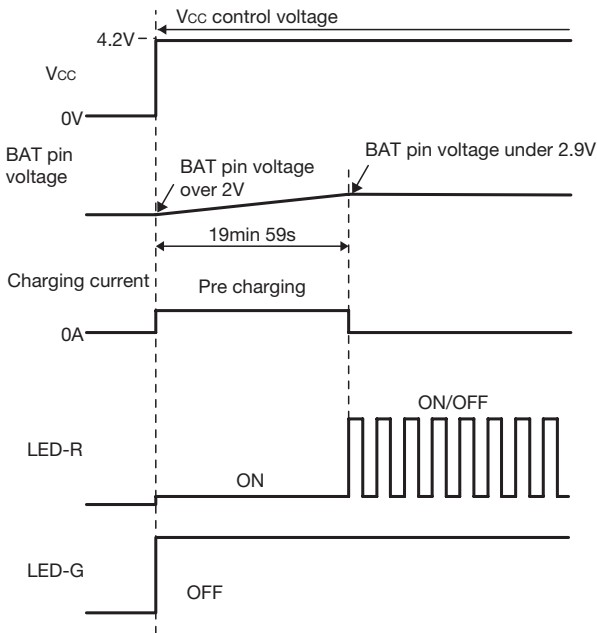

■ Case of time-up for full charging

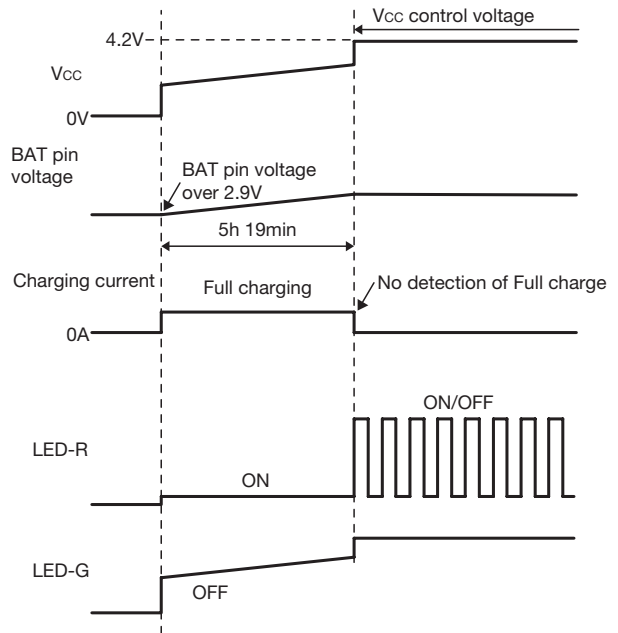

■ Case of Full charged battery

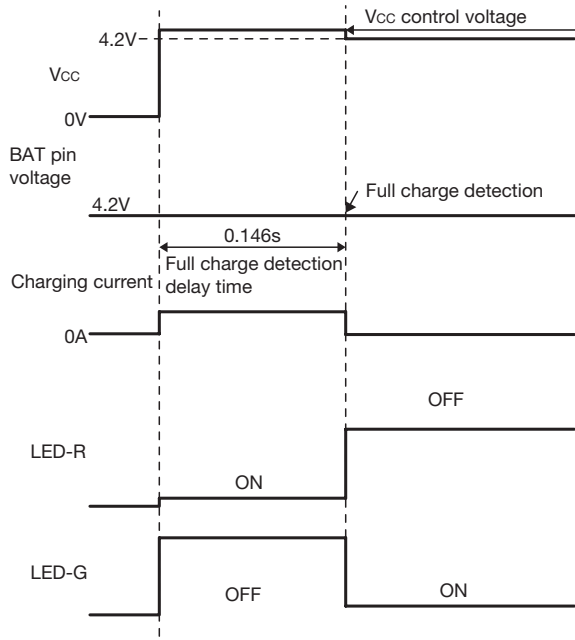

■ Case of Re-charge detection

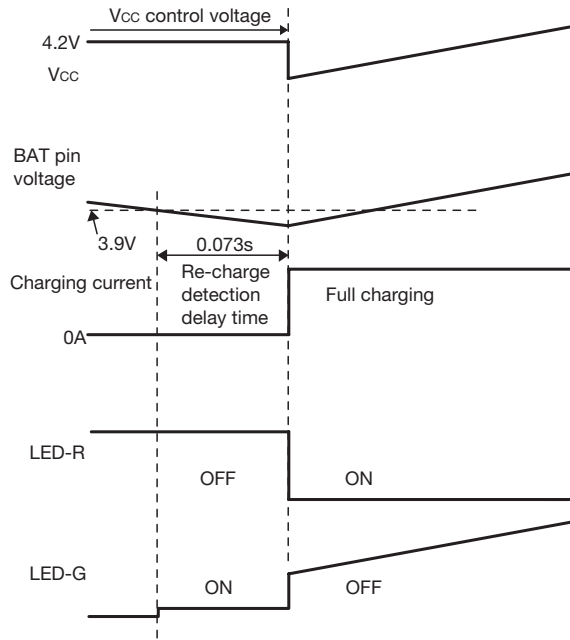

Flow Chart

MM1707BV

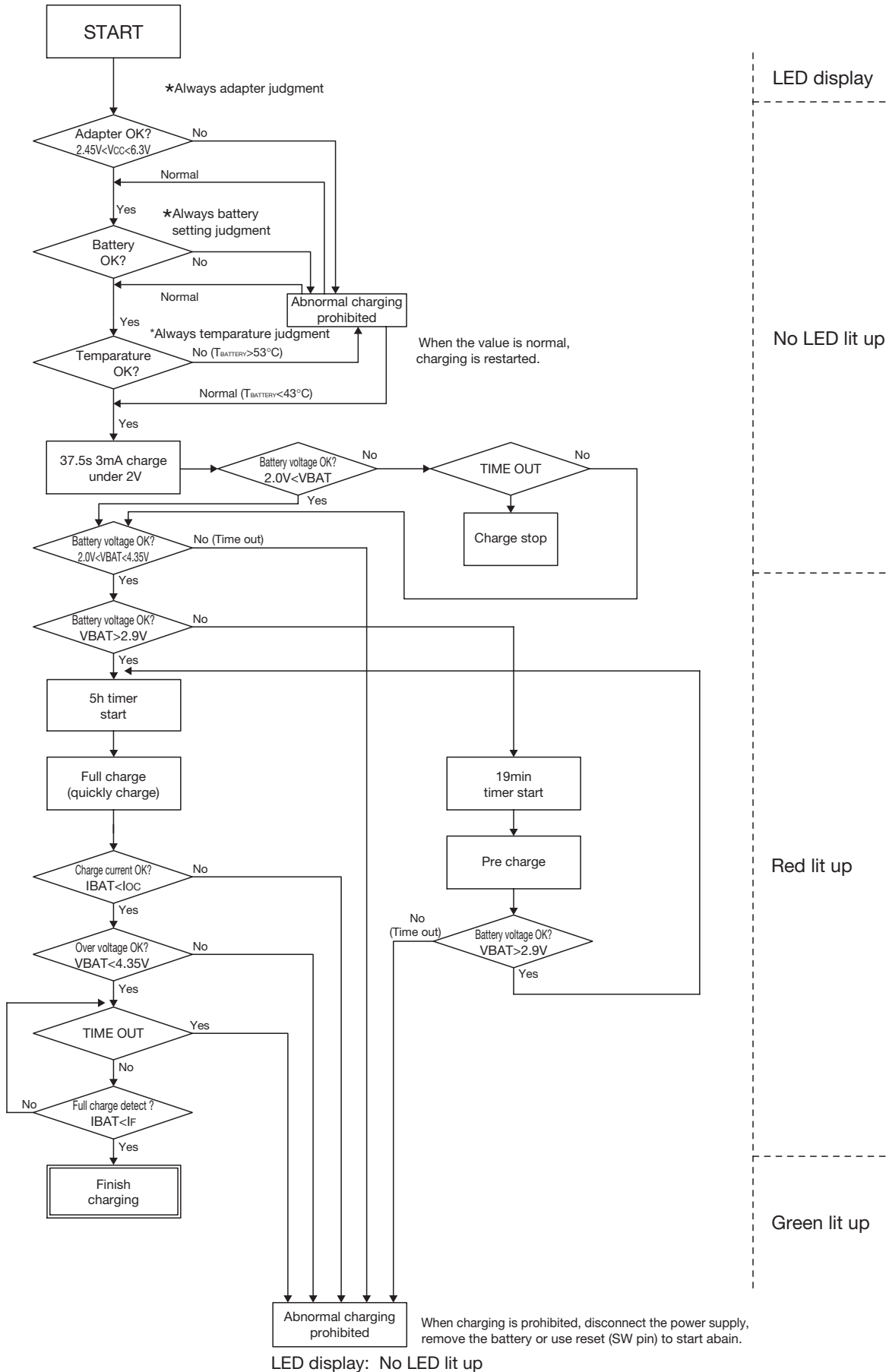

LED display: No LED lit up

MM1707BV

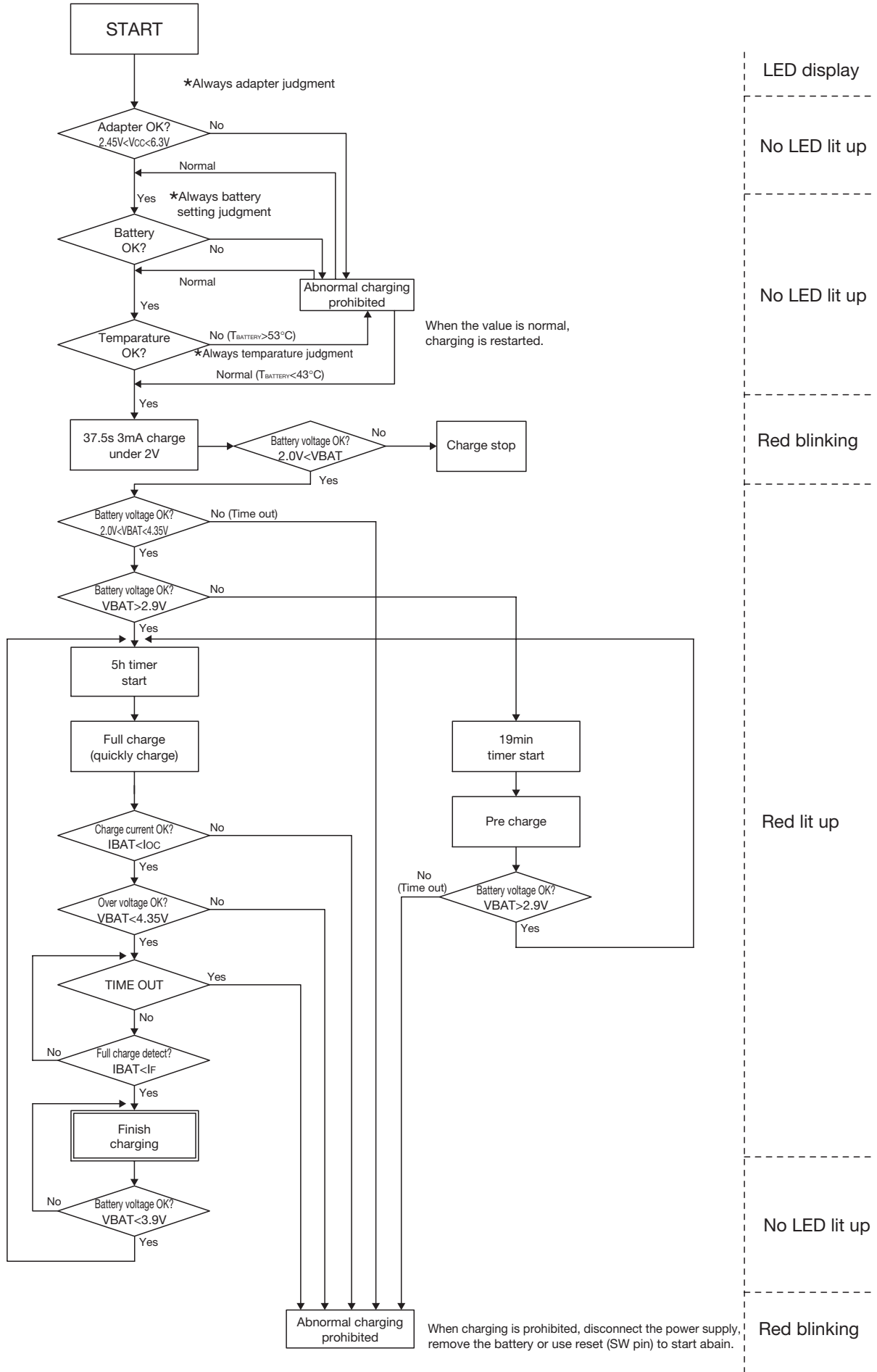

Application Circuit

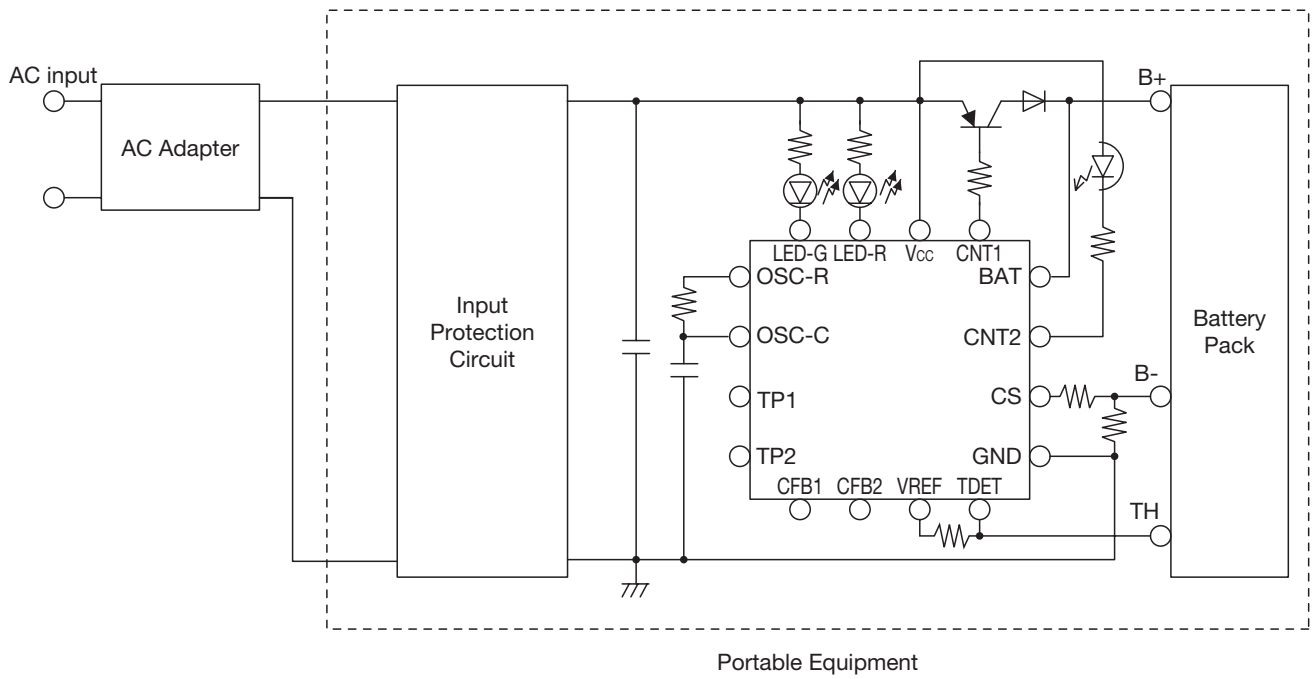

These circuits are typical examples provided for reference purposes, so in actual applications, the circuit constants, conditions and operations should be thoroughly studied.

Mitsumi Electric Co., Ltd. assumes no responsibility for any trouble or damage as a result of the use of these circuits.

Mitsumi Electric Co., Ltd. assumes no responsibility for any infringement of industrial property or any other right of a third party or us, as a result of the use of these circuits.