

Protection for Lithium-Ion Batteries (for double protection) Monolithic IC MM1451

August 3, 1998

Outline

This IC is used for double protection for 1 to 3-cell lithium-ion batteries. The ultra-small package is used for the IC. It can support 1 to 3-serial cell connection by making a short-circuit between each cell.

Features

- | | |
|--|-------------|
| 1. Consumption current (Vcell=3.8V) | 3μA typ. |
| 2. Consumption current (Vcell=2.3V) | 0.3μA typ. |
| 3. Overcharge detection voltage accuracy (−20°C to 70°C) | ±50 mV/cell |
| 4. I/O current between cells (Vcell=3.8V) | ±0.3μA max. |
| 5. Delay time for overcharge voltage detection (Ct=0.22μF) | 1.5s typ. |
| 6. Output current (Vcell=Vcc=4.5 V) | 500μA typ. |

Package

VSOP-8B

Applications

For double protection for 1 to 3-cell lithium-ion batteries

Pin Assignment

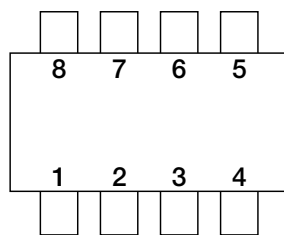

VSOP-8B

1	V3
2	V2
3	V1
4	GND
5	Ct
6	N.C
7	OUT
8	Vcc

Block Diagram

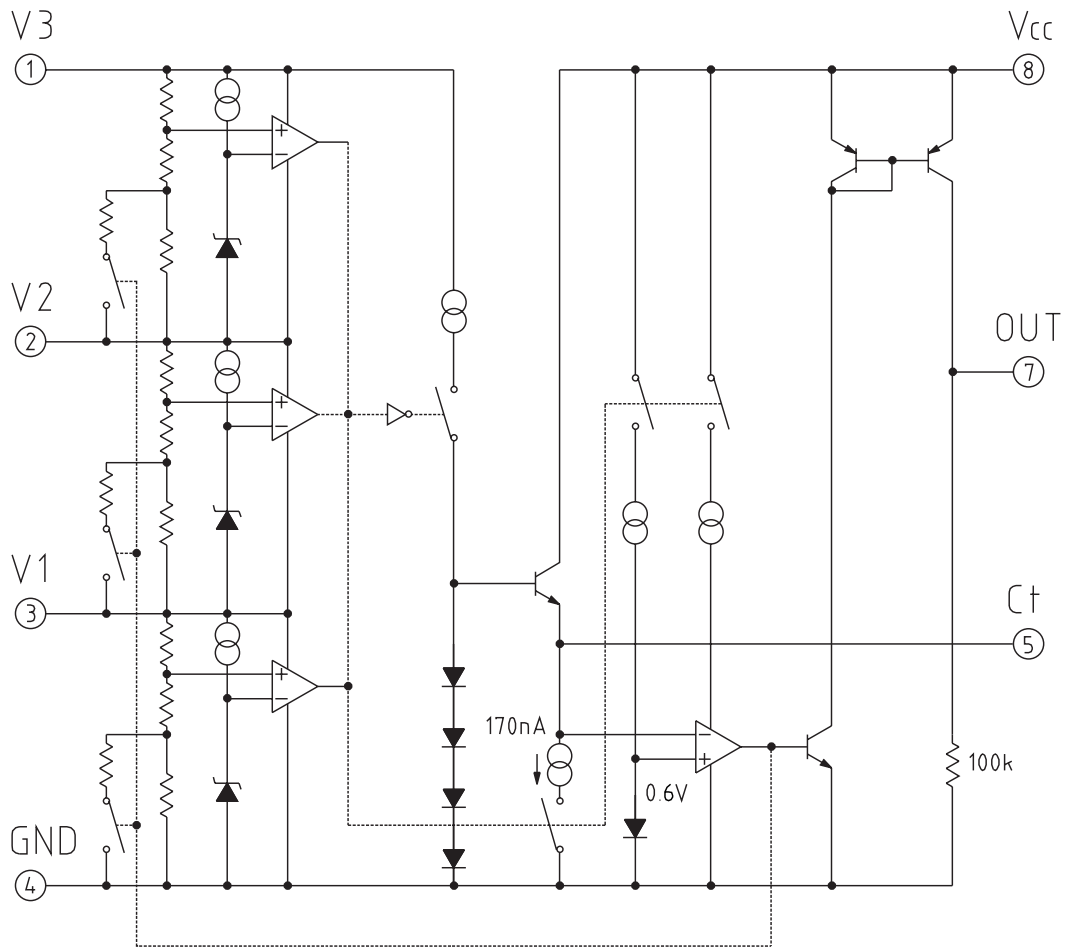

Pin Description

Pin No.	Pin name	Functions	Equivalent circuit diagram
1	V3	3-cell power supply	
2	V2	2-cell power supply	
3	V1	1-cell power supply	
5	Ct	Delay capacity pin	
7	OUT	OUT pin	

Absolute Maximum Ratings (Ta=25°C)

Item	Symbol	Ratings	Unit
Operating temperature	T _{OPR}	-20~+80	°C
Storage temperature	T _{STG}	-40~+125	°C
V _{CC} Input voltage	V _{CC}	-0.3~18	V
V1 Input voltage *1	V1		
V2 Input voltage *1	V2		
V3 Input voltage *1	V3		
Ct pin voltage *2	V _{CT}	-0.3~18	V
V _{OUT} pin voltage	V _{OUT}	-0.3~18	V
Allowable loss	P _d	170	mW

Note 1 : *1 18V ≥ V3 ≥ V2 ≥ V1 ≥ -0.3

Note 2 : *2 Do not impress current of 300μA or more on the Ct pin.

Electrical Characteristics (Except where noted otherwise, Ta=25°C, V_{CEL}=V3-V2=V2-V1=V1-GND, V_{CC}=3×V_{CEL})

Item	Symbol	Measurement conditions	Min.	Typ.	Max.	Unit
Current consumption 1	I ₁	V _{CEL} =3.8V, V _{CC} =V _{CEL} ×3		3.0	6.0	μA
Current consumption 2	I ₂	V _{CEL} =2.3V, V _{CC} =V _{CEL} ×3		0.3	0.5	μA
Pin I/O current between cells	I ₃	V _{CEL} =3.8V (between V3, V2, V1)		±0.0	±0.3	μA
Overcharge detection voltage	V _S	V _{CEL} =L→H Ta=-20~+70°C	4.400	4.450	4.500	V
Hysteresis voltage	Hys	V _{CEL} =L→H→L	35	50	65	mV
Overcharge detection delay time	T _{PLH}	Ct=0.22μF	1.0	1.5	2.0	s
Output current	I _{OH}	V _{CEL} =V _{CC} =4.6V V _O =3V	100	500		μA
Output leakage current	I _{LEAK}	V _{CEL} =3.8V, V _{CC} =18V			0.1	μA

Measuring Circuit

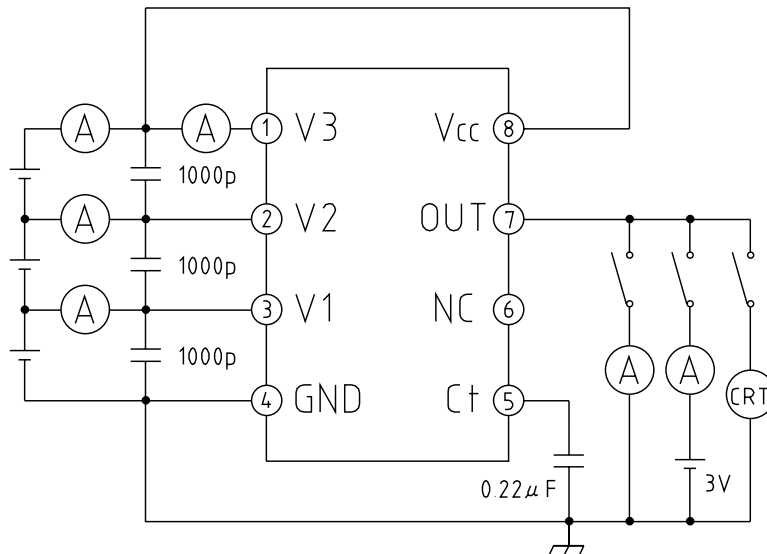

Application Circuit

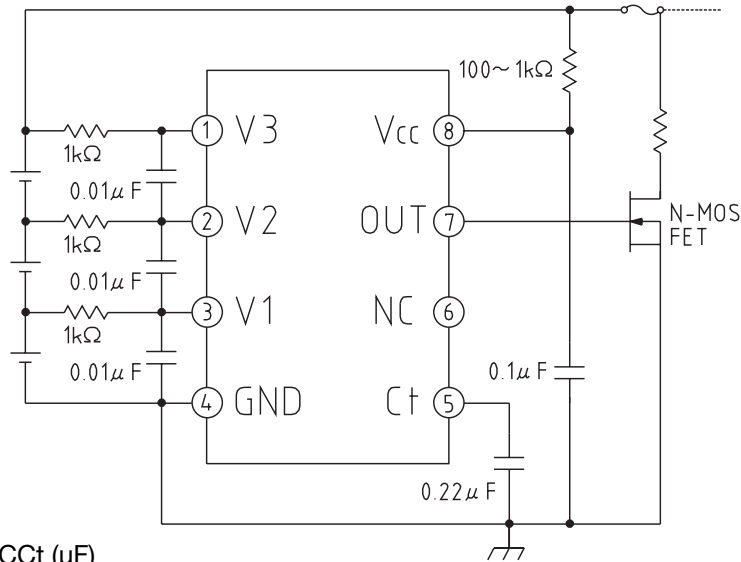

Delay time $T_d(S) = 7 \times C_{ct} (\mu F)$

- Note 1: Can support 1, 2 or 3 cells by shorting each cell. However, be sure to connect a battery for V3 cell. V3 cell may not operate correctly when shorted.
- Note 2: When connecting batteries, be sure to connect in the following order: GND → V3, and Vcc → V1 OR V2.
- Note 3: Output may go ON momentarily when starting up power supply. If this error output during startup becomes a problem, connect the Vcc pin last.
- Note 4: Please confirm operation when making connections other than the above.
- Note 5: The input resistance for each cell should be 1kΩ or lower. Also, please select the appropriate value for the external capacitor according to the usage environment.

Timing Chart

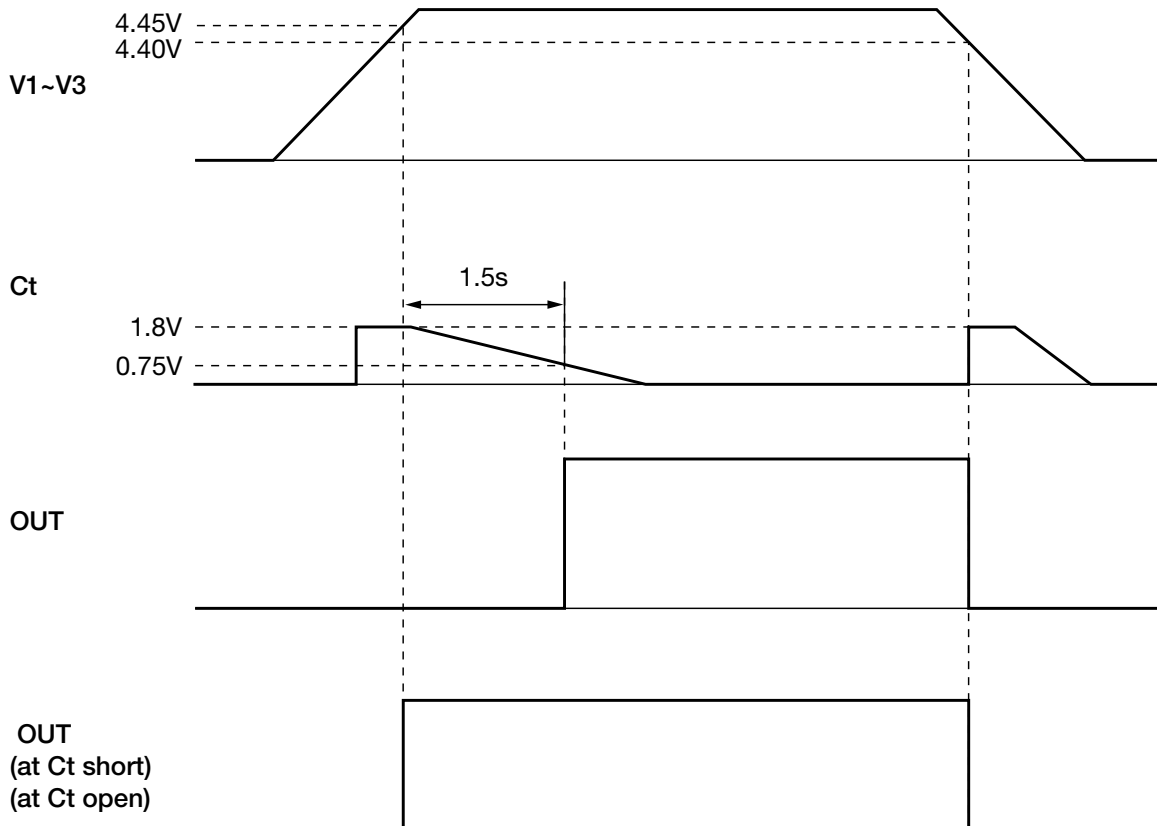

Note: Output goes high simultaneously with overcharge detection at Ct pin short and open.

Characteristics

■ Detection voltage

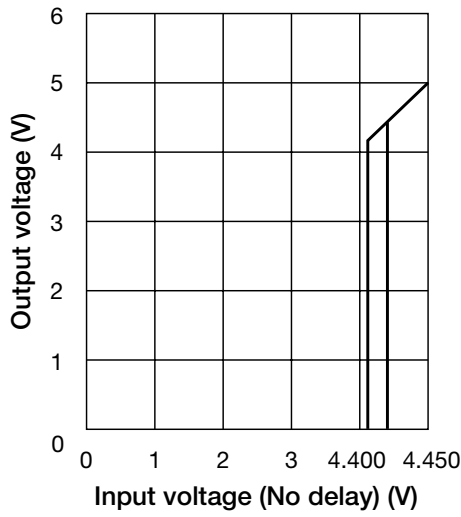

■ Output delay time

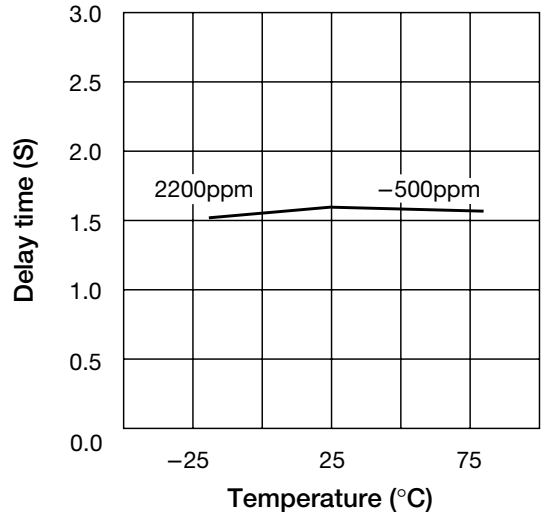

■ Consumption current

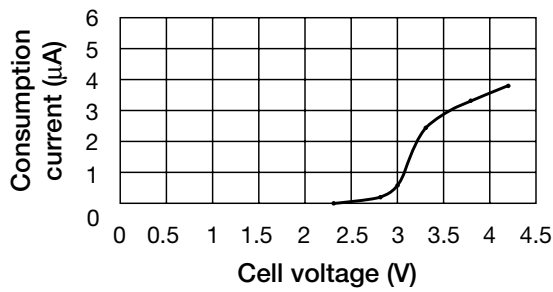

■ Pin I/O current between cells

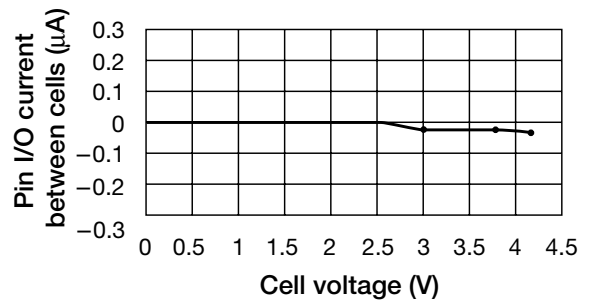

■ Output current

