

Flame Detection Amplifier Monolithic IC MM1217

Outline

This IC is comprised of an operation amplifier, a comparator, and a reference power source. It is worthy of note that the input offset voltage and the input offset voltage temperature drift of this operation amplifier are one digit less than those of conventional products regardless of the single power supply. Formerly, offset voltage adjustment was required for flame detection using a thermocouple on gas appliances, but with this IC adjustment is not required.

Due to the single power supply, low current consumption, and low offset voltage, two batteries can be used for operation, making it appropriate for equipment that amplifies the very small signal of portable equipment.

Features

General

- | | |
|--|---|
| 1. Power supply voltage (single batteries) | $V_{CC}=1.8V\sim 6V$
(It is available to operate by two dry cell batteries.) |
| 2. Current consumption | 0.1mA typ. |
| 3. Power supply line elimination ratio | 60dB typ. |

Amplifier section

- | | |
|---|-------------------------------|
| 1. Low input offset voltage | $\pm 0.1mV$ typ. |
| 2. Low input offset voltage drift ($-20^{\circ}C\sim +75^{\circ}C$) | $\pm 1.0\mu V/^{\circ}C$ typ. |
| 3. Input offset current | 1nA typ. |
| 4. Input bias current | 50nA typ. |
| 5. Voltage gain | 100dB typ. |

Comparator Section

- | | |
|---|------------------------------|
| 1. Input offset voltage | $\pm 1.0mV$ typ. |
| 2. Low input offset voltage drift ($-20^{\circ}C\sim +75^{\circ}C$) | $\pm 10\mu V/^{\circ}C$ typ. |
| 3. Input bias current | $\pm 25nA$ typ. |
| 4. Output sink current | 5mA min. |

Reference Voltage Section

- | | |
|--|-----------------------------|
| 1. Reference voltag | $1.27V\pm 0.05V$ |
| 2. Reference voltage temperature characteristics | $\pm 100ppm/^{\circ}C$ typ. |
| 3. Output current | 0.3mA min. |

Package

- SOP-8D (MM1217XF)
- SIP-9A (MM1217XS)

Applications

- 1. Gas burners
- 2. Instantaneous gas water heaters

Pin Assignment

MM1217XF

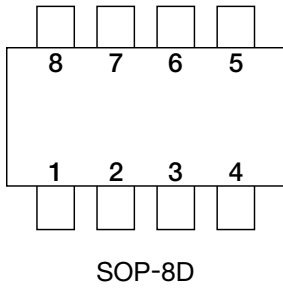

MM1217XS

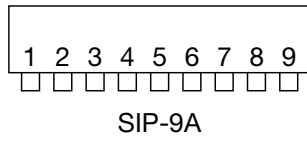

Pin No.	Pin Function	
	MM1217XF	MM1217XS
1	A _{IN+}	A _{IN+}
2	A _{IN-}	A _{IN-}
3	A _{OUT}	A _{OUT}
4	GND	COMP _{IN+}
5	COMP _{IN-}	GND
6	V _S	COMP _{IN-}
7	COMP _{OUT}	V _S
8	V _{CC}	COMP _{OUT}
9	—	V _{CC}

Pin Function (SOP-8D)

Pin No.	Pin Function	Internal Equivalent Circuit	Pin No.	Pin Function	Internal Equivalent Circuit
1	A _{IN+}		5	COMP _{IN-}	
2	A _{IN-}		6	V _S	
3	A _{OUT}		7	COMP _{OUT}	

Block Diagram

MM1217XF

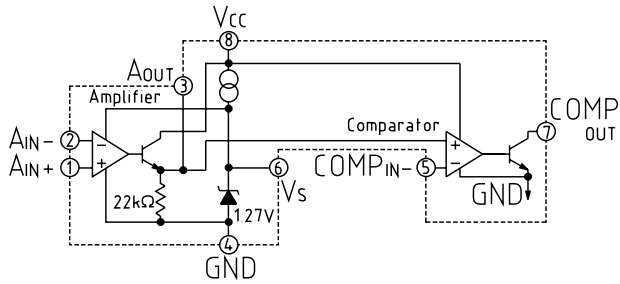

Note: Amplifier and comparator input are PNP type.

MM1217XS

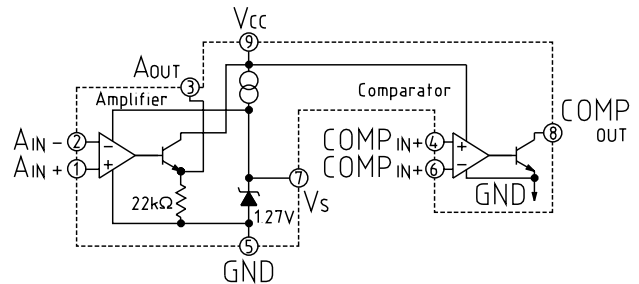

Note: Amplifier and comparator input are PNP type.

Absolute Maximum Ratings (Ta=25°C)

Item	Symbol	Specification	Units
Storage temperature	T _{STG}	-40~+125	°C
Operating temperature	T _{OPR}	-20~+85	°C
Power supply voltage	V _{CC max.}	-0.3~+10	V
Input voltage	V _{IN}	-0.3~+10	V
Allowable power dissipation	Pd	MM1217XF	300
		MM1217XS	470

Electrical Characteristics (Unless otherwise specified Ta=25°C, V_{CC}=3V, V_{IN}=0V)

Item	Symbol	Measurement Conditions	Min.	Typ.	Max.	Units	
Current consumption	I _{CC}			0.1	0.15	mA	
Reference voltage output current	I _{OVs1}		0.3			mA	
Reference voltage	V _{s1}		1.22	1.27	1.32	V	
Reference voltage temperature drift	ΔV _{s1}			±100		ppm/°C	
Power supply line elimination ratio	P _{SRR}	f=100Hz	50	60		dB	
Power supply voltage range	V _{CC}		1.8	3.0	6.0	V	
Amplifier section	Input voltage range	V _I	-0.2		0.3	V	
	Input offset voltage	V _{IOA}		±0.1	±0.35	mV	
	Input offset voltage temperature drift	ΔV _{IOA}		±1.0	±3.0	μV/°C	
	Input offset current	I _{IOA}		1	10	nA	
	Input bias current	I _{BA}		50	150	nA	
	Voltage gain	G _V	R _L =100kΩ	80	100		dB
	Output current	I _{OA}	V _{IN} =10mV, V _{O1} =0.5V	0.5			mA
	Output voltage	V _{OA}	V _{IN} =-5~25mV R _L =10kΩ	0.01		V _{CC} -1.0	V

Electrical Characteristics Unless otherwise specified (Ta=25°C, VCC=3V, VIN=0V)

Item	Symbol	Measurement Conditions	Min.	Typ.	Max.	Units
Comparator	Input offset voltage	V _{IOC}		±1.0	±3.5	mV
	Input offset voltage temperature drift	ΔV _{IOC}		±10	±30	μV/°C
Section	Input bias current	I _{BC}		25	75	nA
	Output sink current	I _{SINK}	V _{IN} =10mV, V _{O2} =0.4V	5		mA
	Output leak current	I _{LC}	V _{O2} =V _{CC} +1V			0.2 μA
	Output saturation voltage	I _{SAT}	V _{IN} =10mV, I _{SINK} =5mA		200	400 mV

Note 1 : Amplifier output ... emitter-follower (pull-down resistance 22kΩ)

Note 2 : Comparator output ... open collector

Application Circuits

Flame detection circuit using a thermocouple (single power source)

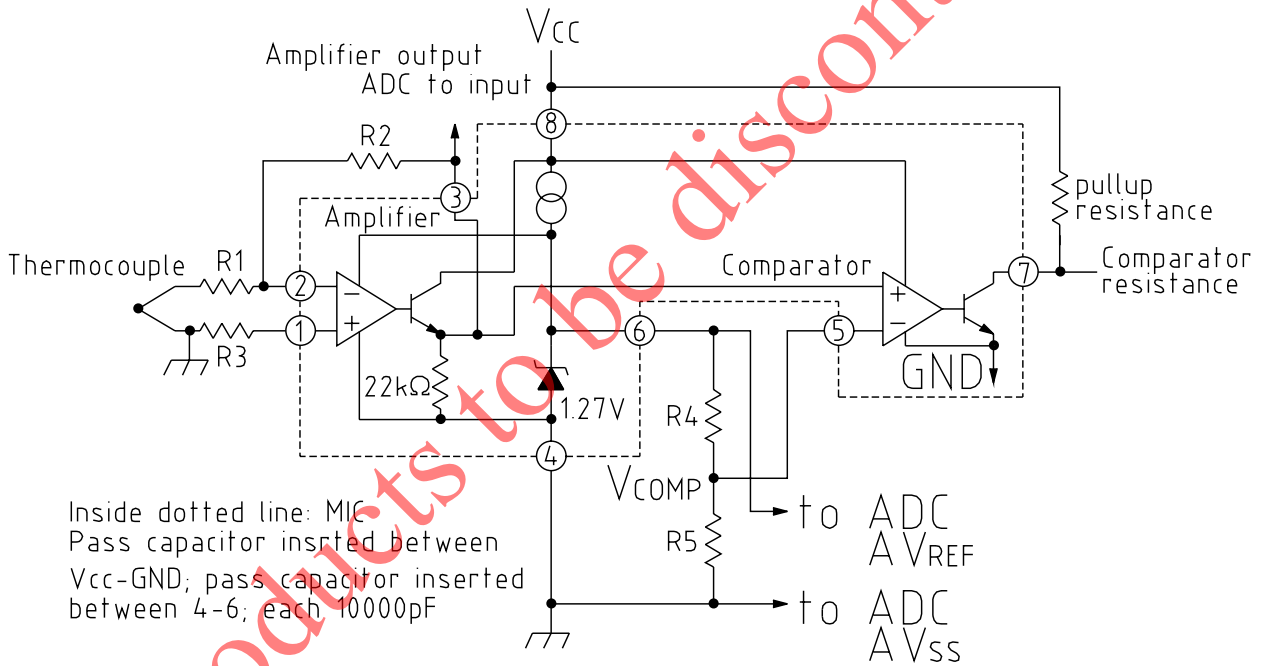

Note 1: Use a gain range of 20dB-50dB in the amplifier section (40dB recommended) .

Also, insert the capacitor between output 3 and GND instead of parallel to R2 in order to eliminate noise from the input. Please note that use of the equipment under different conditions will cause vibration.

Note 2: Applicable circuits shown are typical examples provided for reference purposes. Mitsumi cannot assume responsibility for any problems arising out of the use of these circuits or for any infringement of third party patent and other right due to same.