

# System Reset Monolithic IC PST575

## Outline

This IC functions in a variety of CPU systems and other logic systems, to detect power supply voltage and reset the system accurately when power is turned on or interrupted. This ultra-low current consumption low reset type system reset IC has a built-in delay time generating circuit that can set the time by an external capacitor and resistor. It is ideal for use in multi-CPU systems because a fast-rising output waveform can be obtained.

## Features

1. Ultra-low current consumption
2. Low operating limit voltage
3. Output current high for ON
4. Hysteresis voltage provided in detection voltage
5. Delay time can set over a wide range using external capacitor and resistor.
6. 10 ranks of detection voltage

$I_{CCH}=7.5\mu A$  typ.  $I_{CCL}=400\mu A$  typ.  
 0.65V typ.  
 30mA typ.  
 50mV typ.

10 $\mu S$ –10S

PST575	C : 4.5V typ.	H : 3.1V typ.
	D : 4.2V typ.	I : 2.9V typ.
	E : 3.9V typ.	J : 2.7V typ.
	F : 3.6V typ.	K : 2.5V typ.
	G : 3.3V typ.	L : 2.3V typ.

## Package

MMP-4A (PST575□M)

DIP-8A (PST575□)

\*□ contains detection voltage rank

## Applications

1. Reset circuits in microcomputers, CPUs and MPUs (especially multi-CPU sets)
2. Logic circuit reset circuits.
3. Battery voltage check circuits.
4. Back-up power supply switching circuits.
5. Level detection circuits.

## Pin Assignment

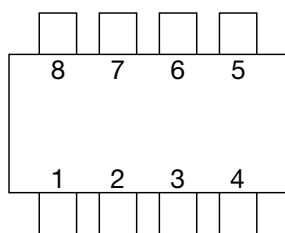

DIP-8A

3	GND
4	Cd
5	V <sub>OUT</sub>
7	V <sub>CC</sub>

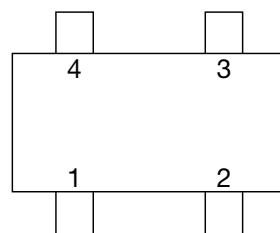

MMP-4A

1	V <sub>CC</sub>
2	V <sub>OUT</sub>
3	Cd
4	GND

Equivalent Circuit Diagram

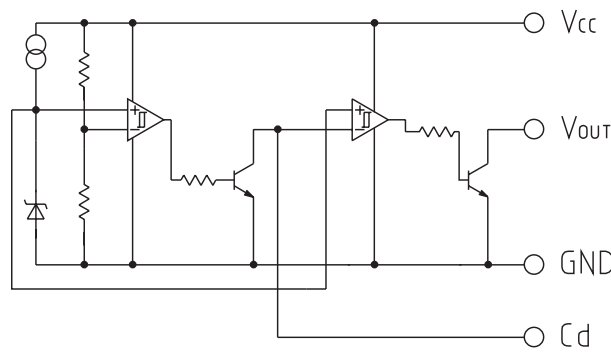

Absolute Maximum Ratings (Ta=25°C)

Item	Symbol	Rating	Units
Storage temperature	T <sub>STG</sub>	-40~+125	°C
Operating temperature	T <sub>OPR</sub>	-20~+75	°C
Power supply voltage	V <sub>CC</sub> max.	-0.3~10	V
Allowable loss	P <sub>d</sub>	200 (MMP-3A) 300 (TO-92A)	mW

Electrical Characteristics (Ta=25°C) (Except where noted otherwise, resistance unit is Ω)

Item	Symbol	Measuring circuit	Measurement conditions	Min.	Typ.	Max.	Units	
Detection voltage	V <sub>s</sub>	1	R <sub>L</sub> =470 V <sub>OL</sub> ≤ 0.4V V <sub>CC</sub> =H→L	PST575C	4.3	4.5	4.7	V
				PST575D	4.0	4.2	4.4	
				PST575E	3.7	3.9	4.1	
				PST575F	3.4	3.6	3.8	
				PST575G	3.1	3.3	3.5	
				PST575H	2.9	3.1	3.3	
				PST575I	2.75	2.90	3.05	
				PST575J	2.55	2.70	2.85	
				PST575K	2.35	2.50	2.65	
PST575L	2.15	2.30	2.45					
Hysteresis voltage	ΔV <sub>s</sub>	1	R <sub>L</sub> =470, V <sub>CC</sub> =L→H→L	25	50	100	mV	
Detection voltage temperature coefficient	V <sub>s</sub> /ΔT	1	R <sub>L</sub> =470, Ta=-20°C~+75°C		±0.01		%/°C	
Low-level output voltage	V <sub>OL</sub>	1	V <sub>CC</sub> =V <sub>s</sub> min.-0.05V, R <sub>L</sub> =470		0.1	0.4	V	
Output leakage current	I <sub>OH</sub>	1	V <sub>CC</sub> =7.5V			±0.1	μA	
Circuit current while on	I <sub>CC</sub> L	1	V <sub>CC</sub> =V <sub>s</sub> min.-0.05V, R <sub>L</sub> =∞		400	650	μA	
Circuit current while off	I <sub>CC</sub> H	1	V <sub>CC</sub> =V <sub>s</sub> typ./0.85V, R <sub>L</sub> =∞		7.5	12.0	μA	
"H" transport delay time	tpLH	2	R <sub>d</sub> =100k, C <sub>d</sub> =0.01μF *1	0.75	1.25	1.75	mS	
"L" transport delay time	tpHL	2	R <sub>d</sub> =100k, C <sub>d</sub> =0.01μF *1		6	20	μS	
Operating power supply voltage	V <sub>op</sub> L	1	R <sub>L</sub> =4.7kΩ, V <sub>OL</sub> ≤ 0.4V		0.65	0.85	V	
Output current while on I	I <sub>OL</sub> I	1	V <sub>CC</sub> =V <sub>s</sub> min.-0.05V, R <sub>L</sub> =0	8	30		mA	
Output current while on II	I <sub>OL</sub> II	1	Ta=-20°C~+75°C, R <sub>L</sub> =0 *2	5			mA	
Threshold voltage for delay time setting comparator (CO2)	V <sub>tsh</sub>	1	V <sub>CC</sub> =5.0V, R <sub>d</sub> =100k, C <sub>d</sub> =0.01μF R <sub>L</sub> =4.7k, C <sub>L</sub> =100pF	3.5	3.7	3.9	V	

\*1 : tpLH : V<sub>CC</sub>= (V<sub>s</sub> typ.-0.4V) → (V<sub>s</sub> typ.+0.4V), tpHL : V<sub>CC</sub>= (V<sub>s</sub> typ.+0.4V) → (V<sub>s</sub> typ.-0.4V), C<sub>L</sub>=100pF

\*2: V<sub>CC</sub>=V<sub>s</sub> min.-0.15V

**Measuring Circuit** (Example: PST575C)

[1]

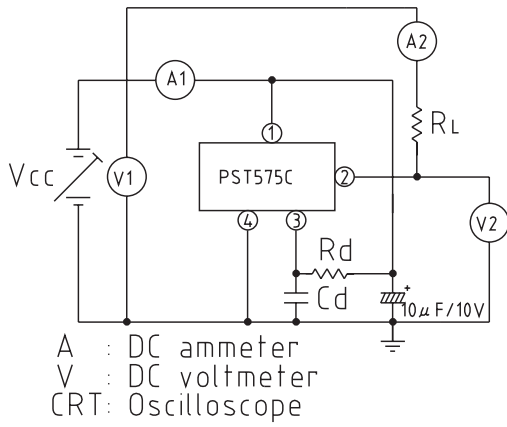

[2]

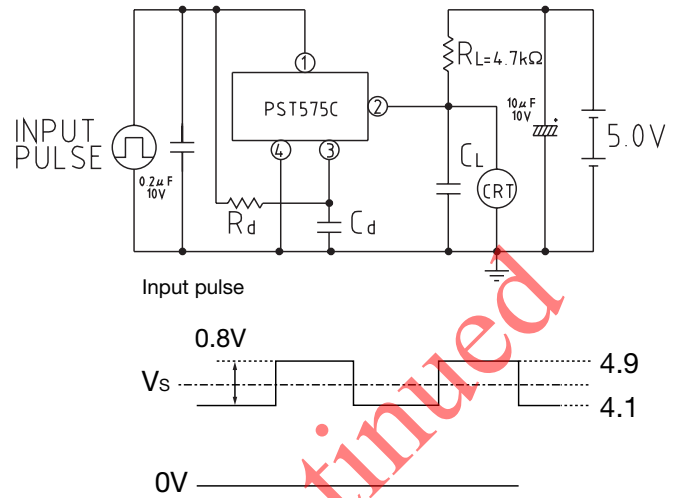

Note: Input model is an example for PST575C (MMP-4P).

**Characteristics** (Example: PST575C)

■ VCC vs. VOUT

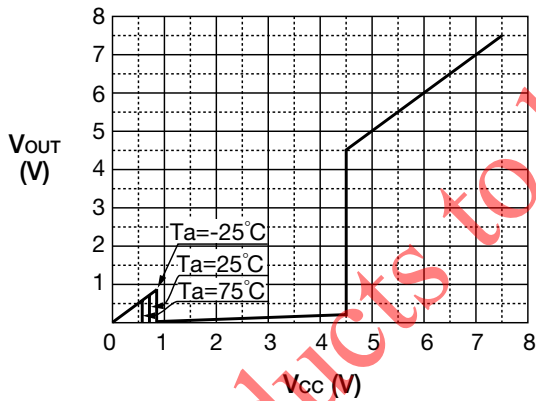

■ VCC vs. ICC

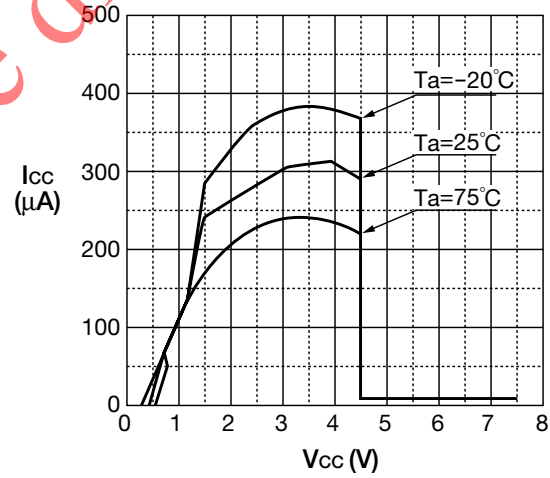

■ Vs vs. Ta

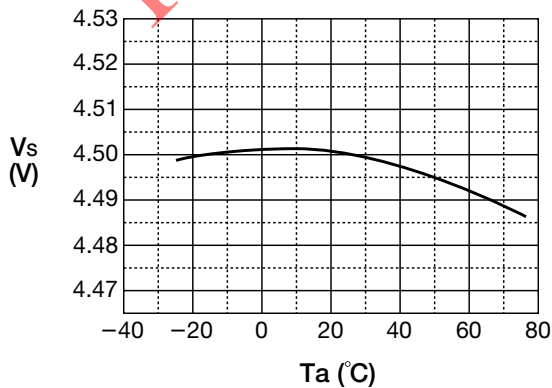

■ ΔVs vs. Ta

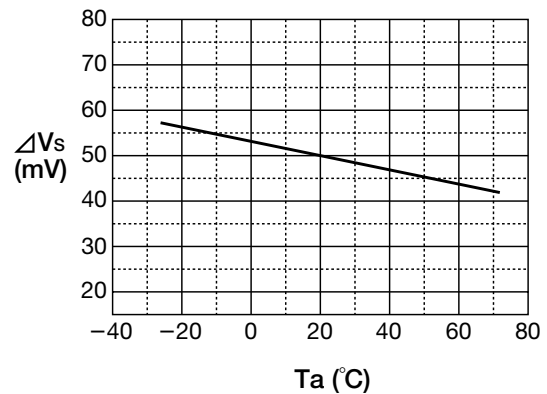

■ I<sub>OL</sub> vs. Ta

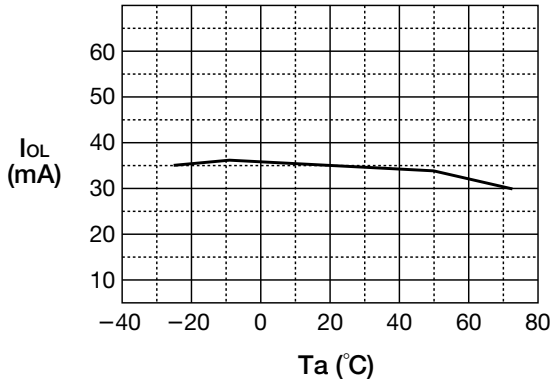

■ V<sub>OL</sub> vs. Ta

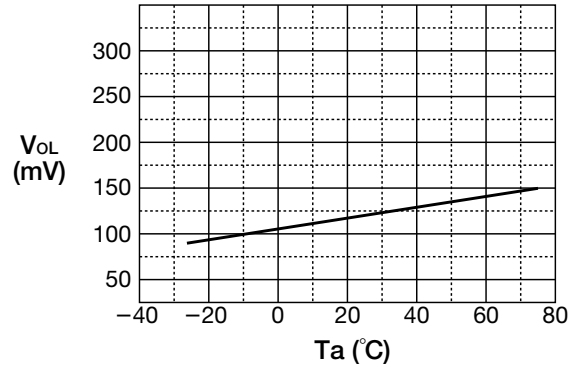

■ I<sub>CCH</sub> vs. Ta

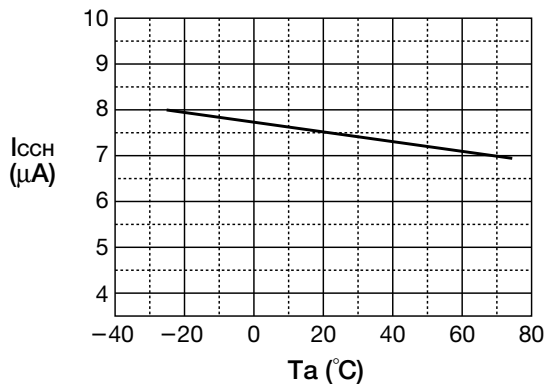

■ I<sub>CCL</sub> vs. Ta

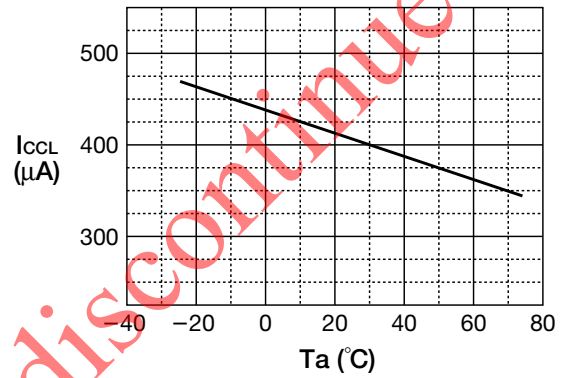

■ Cd (R<sub>d</sub>) vs. tpLH

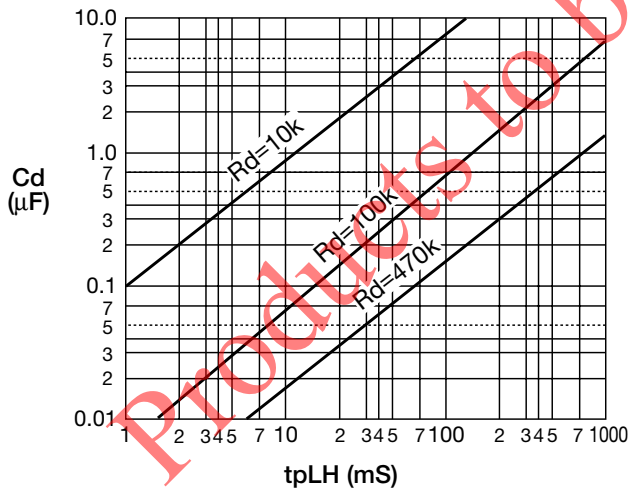

■ tpLH vs. Ta

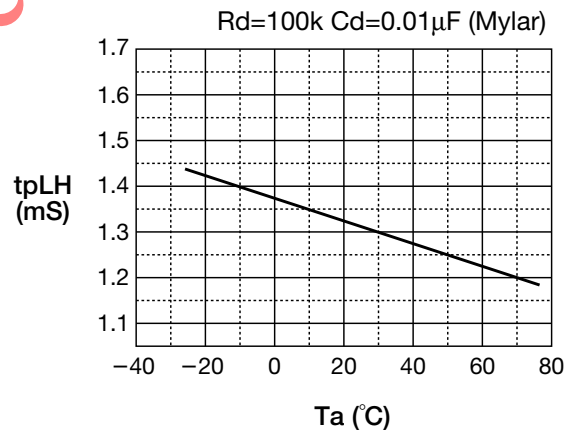

■ Pd vs. Ta

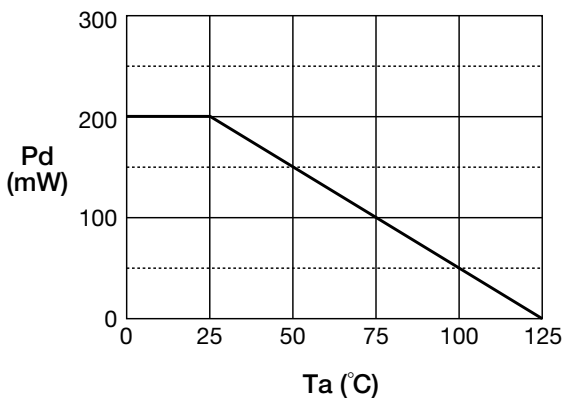

Timing Chart

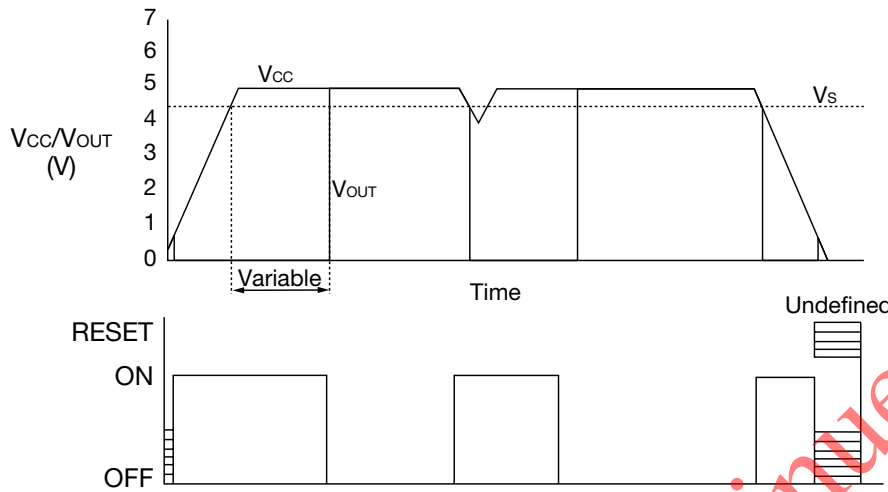

Application Circuits (Pin numbers are for an example of MMP-4P.)

1. Normal hard reset

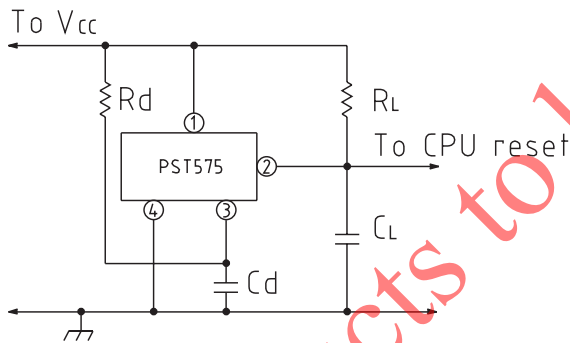

Delay time (tPLH)

$$\approx 1.3C_d \times R_d + 0.007 \text{ (mS)}$$

Cd :  $\mu\text{F}$     Rd :  $\text{k}\Omega$

Note: Connect a capacitor between IC pins 1 and 2 if Vcc line impedance is high.

2. Manual reset added

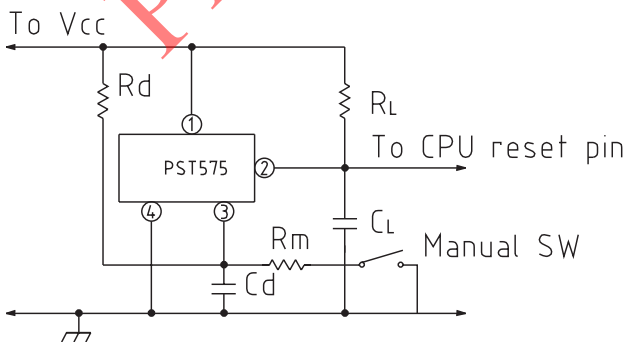

Note: Use RL, CL and Rm to prevent manual switch chattering. Connect a capacitor between IC pins 1 and 2 if Vcc line impedance is high.

3. Battery checker (LED ON for high voltage)

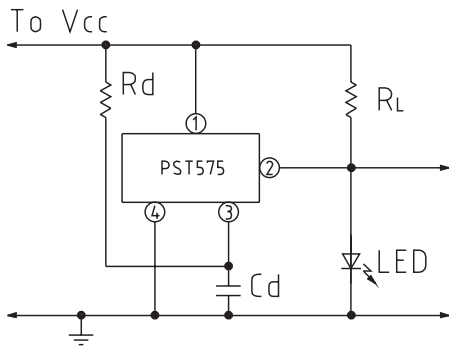

Note: Connect a capacitor between IC pins 1 and 2 if Vcc line impedance is high.

4. Battery checker (LED ON for low voltage)

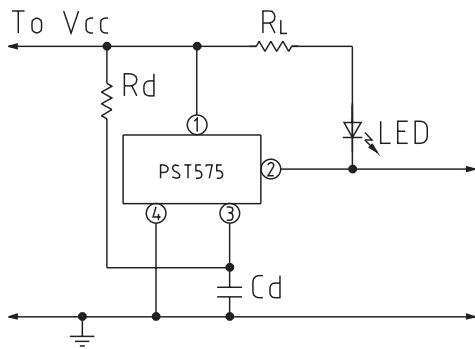

Note: Connect a capacitor between IC pins 1 and 2 if Vcc line impedance is high.

5. Hysteresis voltage UP method

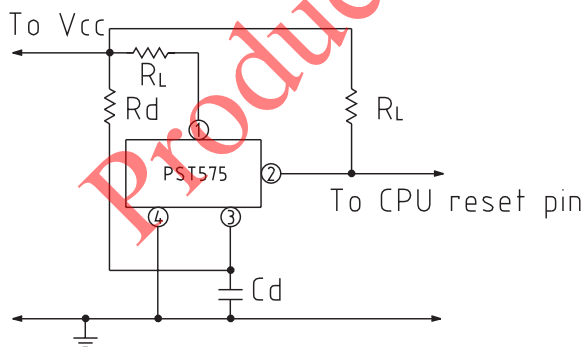

When increasing hysteresis voltage for stable system operation, determine RH as follows and connect externally.

However, I<sub>CCH</sub> is -5000PPM/°C, so perform temperature compensation at RH when using over a wide temperature range.

Hysteresis voltage UP amount ( $\Delta V_{sup}$ ) is

$$\Delta V_{sup} \approx RH \times I_{CCL}$$

Total hysteresis voltage ( $\Delta V_{stotal}$ ) is

$$\Delta V_{stotal} \approx V_s + \Delta V_{sup}$$

(Operation will be destabilized is RH is raised too much.)

Note: Connect a capacitor between IC pins 1 and 2 if Vcc line impedance is high.

